

Drums
HANDCRAFTED SINCE 1967

Yamaha Global Web
<https://www.yamaha.com/>
Drums
<https://www.yamaha.com/drums>

Drums
HANDCRAFTED SINCE 1967

DTX
drums

*Some models may not be available in some countries.
*Colors shown in this catalog may not be represented exactly
as the original colors due to printing processes involved.
*Specifications are subject to change without notice.

We Play Yamaha

Featured Artist



Tommy Aldridge
WHITESNAKE
Rick Allen
Def Leppard
Cliff Almond
Michel Camilo, Manhattan Transfer, Akiko Yano, Quruli
Carter Beauford
Dave Matthews Band
Mike Bordin
Faith No More
Paul Bostaph
SLAYER
Gerry Brown
Diana Ross



Matt Cameron
Soundgarden, Pearl Jam
Gorden Campbell
American Idol, George Duke, Jessica Simpson
Teddy Campbell
American Idol
Terri Lyne Carrington
Herbie Hancock, Mosaic Project
Iggor Cavalera
Soulwax, Petrick
Matt Chamberlain
Independent
Jimmy Chamberlin
Smashing Pumpkins
Will Champion
Coldplay
Oliver Charles
Ben Harper & Innocent Criminals, Gogol Bordello



Mark Colenburg
Robert Gasper, Maxwell
Jason Cooper
The Cure
Mickey Curry
Brian Adams, David Bowie, Elvis Costello
Josh Dion
Josh Dion Band, Paris Monster
Charley Drayton
Independent, Cold Chisel
Sonny Emory
Earth Wind & Fire, Stanley Clarke, David Sanborn, Bette Midler, Al Jarreau, LeeRitennour
Sully Erna
Godsmack
Anton Fig
Joe Bonamassa, Independent
Justin Foley
Killswitch Engage

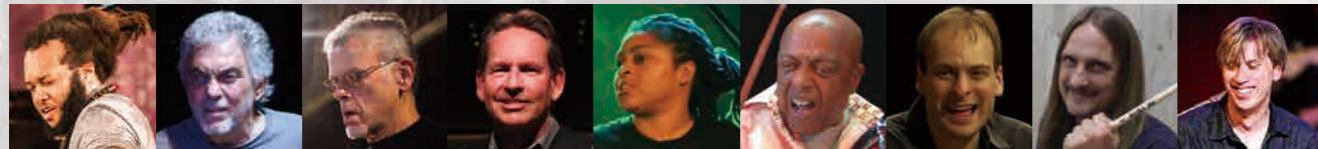

Corey Fonville
Christian Scott, Butcher Brown
Steve Gadd
Eric Clapton, James Taylor, Paul Simon
David Garibaldi
Tower Of Power
Bill Gibson
Huey Lewis & The News
Nikki Glaspie
The Nth Power
Roy Haynes
Miles Davis, Louis Armstrong
Ari Hoenig
Mike Stern, Kenny Werner, Richard Bona, Chris Potter
Tom Hunting
EXODUS
Tommy Igoe
Birdland Jazz Orchestra



Ali Jackson
Wynton Marsalis, Lincoln Center Jazz Orchestra, James Carter, Dee Dee Bridgewater, Aretha Franklin, George Benson
Akira Jimbo
Casiopea 3rd, One man Orchestra
Chris Johnson
Lady GaGa, Jennifer Lopez, Camila Cabello
Steve Jordan
Eric Clapton, The Verbs, John Mayer
Manu Katche
Sting, Peter Gabriel
Senri Kawaguchi
Independent
Shannon Larkin
Godsmack
Larnell Lewis
Snarky Puppy
Dave McClain
Sacred Reich



Derrick Mckenzie
Jamiroquai
Dominique Messier
Celine Dion, McCoy Tyner, Freddie Hubbard, Wynton Marsalis, Jackie McLean, Clark Terry, Milt Jackson, Ron Carter, Charlie Haden, Eddie Gomez
Jamie Miller
Bad Religion
Larry Mullen, Jr.
U2
Khari Parker
George Benson
Dafnis Prieto
Michel Camilo, Proverb Trio, Si O Si Quartet
John Riley
Vanguard Jazz Orchestra
Ralph Rolle
Nile Rodgers CHIC
Jamison Ross
Independent, Snarky Puppy



Antonio Sanchez
Pat Metheny, Solo Artist, Migration
Neil Sanderson
Three Days Grace
Erik Sandin
NOFX
Kendrick Scott
Terence Blanchard, Kendrick Scott Oracle
Oscar Seaton
Lionel Richie, George Benson
Richard Spaven
José James, Richard Spaven Trio, Flying Lotus
Ian Thomas
Eric Clapton, Mark Knopfler
Jason "JT" Thomas
Snarky Puppy, RH Factor, Phillip Phillips, Forq
Dave Weckl
Mike Stern, Dave Weckl Acoustic Band

USA



Ludwig Afonso
Richard Bona
Zachary Alford
David Bowie, Tomoyasu Hotel
Chris Bailey
Independent
Michael Baker
GAVIN DEGRAW
Donald Barrett
Independent
Marcus Baylor
Kenny Garrett
Veronica Bellino
Life of Agony
Mike Bennett
Richie Kotzen
Ignacio Berroa
Independent
Johnathan Blake
Kenny Barron, Tom Harrell



Bobby Blotzer
Independent
Zak Bond
Independent
Elena Bonomo
Broadway / Waitress the Musical
Jimmy Branly
Gonzalo Rubalcaba, Benny Goodman Orchestra
Tom Brechtlein
Chick Corea, Wayne Shorter, Robben Ford
Ray Brinker
Tierney Sutton Band, Gordon Goodwin's Big Phat Band
Carrington Brown
H.E.R.
Otis Brown III
Joe Lovano, Stanley Clarke
Scot Coogan
L.A GUNS
Gene Coye
Seal, John Scofield



Aaron Comess
Spin Doctors
Chris Dalley
IMPLANTS, AUTHORITY ZERO
Austin D'Amond
Devildriver
Quincy Davis
University of North Texas
Jovan Dawkins
Independent
Henrique Dealmeida
Independent
Shawn Drover
Act of Defiance
Phil Ehart
Kansas
Efa Etorama Jr.
Independent
Al Foster
Sonny Rollins, Herbie Hancock, McCoy Tyner



Paul Francis
Lady Gaga Jazz Band
Matt Frenette
Loverboy
Jermey Furstenfeld
Blue October
Adam Gomez
The Dickies
Terreon Gully
Junko Onishi, Dianne Reeves, John Beasley
Clint de Ganon
Art Garfunkel, John Tropea, Frank Wildhorn
Keith Hall
Western Michigan University
Steve Hass
Patti Austin, Manhattan Transfer
Stockton Helbing
University of North Texas
Chris Hesse
Hoobastank



Wendell Holmes Jr.
Ryan Follese
Ralph Humphrey
Dancing With The Stars
Susie Ibarra
Independent
Victor Jones
Dizzy Gillespie, Andrienne Wilson, Chaka Khan
Willie Jones III
Cedar Walton Trio, Roberta Gamberini
Lee Kelley
Hank Williams Jr.
Ryan Kittlitz
All Hail the Yeti
Andrew Lee
Saint Paul and the Broken Bones
Paul Leim
Lionel Richie, Kenny Rogers
Pete Magadini
Independent



Jerry Marotta
Security Projec
Rick Marotta
Independent
Phillip Martin
Independent
Dave Mattacks
Independent
Drew Mckeon
Michael Bolton
Allison Miller
Allison Miller's Boom Tic Boom
Tony Moore
George Benson, Bobby Caldwell
Dan Needham
Michael McDonald
Ian O'Neill
Lady Antebellum
Max Nudi
Independent



Gianluca Palmieri
Independent
Chris Parker
Brecker Brothers, Miles Davis, Bob Dylan, NYC Broadway, Akiko Yano Trio
Felix D-kat Pollard
Keiko Matsui, House of Pain
Prairie Prince
The Tubes, Jefferson Starship, Todd Rundgren
Corey Rawls
Independent
Jon Rice
Scorpion Child
JIZMak da Gusha/Brad Roberts
GWAR
Francis Ruiz
Buckcherry
Steve Schaeffer
Independent
Mike Shapiro
Herb Alpert

USA



Ben Smith Roadcase Royale, Jake Sommers Luke Combs, Robert Sweet Stryper, Adam Topol Jack Johnson, Eric Valentine Steve Lukather, Peter White, Mark Walker Paquito D'Rivera, Jay Ware Independent, Vincent Wilburn Jr. Independent, Buddy Williams Manhattan Transfer, George Benson, Jay Williams Jonathan Butler

Canada



Chad Wright The Jacksons, Michael Bolton, Doug Yowell Joe Jackson, Steve Augustine Thousand Foot Krutch, Julien Blais PIRATE, Paul Brochu UZEB, StudioMaster, Joel Cassidy Walk of the Earth, Ian Casselman Marianas Trench, Randy Cooke LA session, Studio Master, Gary Craig Bruce Cockburn, Tom Cochrane, Jordan Hastings Billy Talent



Mark Kelso Hilario Duran, Humber College, Jazz Exile, Steve Kiely Monster Truck, Maxime Lalanne Marie Mai, Belle et Bum, Kris MacFarlane Great Big Sea, Studio, Mark McLean George Michael, Independent, Glenn Milchem Blue Rodeo, Nik Pesut Carley Rae Jepsen, Jules Scott-Key METRIC, Ali Siadat Mother Mother, Mike Sleath Shawn Mendes

Bolivia

Chile

Colombia

Costa Rica

Ecuador



SarahThawer Independent, Josh Trager Sam Roberts Band, Pablo Pelaez Salazar "MORTSURE", Michael Dumay HSUR, Nelson Amarillo Maia, Mojarrá Electrica y banda de Jazz, Pablo Bernal Carlos Vives (La Provincia), Juan Guillermo Aguilar B Independent, Alex Monsa Independent, Carlos Sanders Transfusión, Swing en 4, Frank Guerrero Independent, Educator

El Salvador UK



Saed Zabana Fausto Miño, GSR, Benjamín Andrade Alter Ego, Moses Boyd Independent, Yussef Dayes Independent, Geoff Dunn Procol Harum, Donovan Hepburn ADELE, Oli Murs, Kenney Jones The Jones Gang, Faces, The Who, The Faces, Bob Knight The Pogues, Cee Lo Green, Rumer, Troy Miller LAURA MVULA, AMY WINEHOUSE, Mark Mondesir Independent

Austria

Belgium



Andrew Newmark Jim Keltner, David Sanborn, Sly & the Family Stone, Ian Palmer Ray Russell, Gary Powell The Libertines, New York Dolls, Neil Primrose Travis, Dave Rowntree Blur, Andrew Small IL DIVO, Mikey Sorbello The Graveltones, Steve White Paul Weller, The Family Silver, Lukas Hasitschka of Wanda, Bruno Castellucci Chet Baker, Quincy Jones

Denmark



Jef Vandervorst Independent, Claes Antonsen The Antonelli Orchestra, Thomas Drachmann Christopher, Peter Düring Rasmus Seebach, Henrik Engqvist Independent, Mark Falgren Lukas Graham, Søren Friis Dizzy Mizz Lizzy, Soeren Frost DR Big Band, Jon Grundtvig-Poulsen Ida Nielsen, Sanne Salomonsen, Jacob Hatholt Independent

Denmark

Egypt

Estonia

France



Morten Lowe Sørensen Amarante, Michel Svane L.O.C., Frank Thøgersen Independent, Bastian Thusgaard Christiansen Soilwork, Ahmed Rabie Independent, Boris "Borka" Hrebtkov Independent, Romain Bachelard Pascal Obispo, Jean Baptiste Tronel <Job> Tagada Jones, Nicolas Bastos Deep In Hate, L'Esprit Du Clan, André Ceccarelli Independent

Germany



Matthieu Chazarenc Olivia Ruiz, Daniel Humair Independent, Romain Joutard hristophe Maé, Manu Masko Celtic Social Club, Nicolas Viccaro Hyleen, Zigo Dub Inc, Bela B. die arzte, Moritz Baumgaertner Bonaparte, Lisbeth Quartett, Jonas Burgwinkel Independent, Merlín Ettore [trap]



Ralf Gustke Soehne Mannheim, Schiller, Wolfgang Haffner Chuck Loeb, Wolfgang Haffner Trio, Reiner Kallas Caethé, Mark Foster, Max Marschk Kraftklub, Patrick Metzger Independent, Carl Michael Grabinger Max Herre, Jazzanova, Onkel Ohrbooten, Aliigatoah, Roland Roy Knaut Marteria, Seed, Eric Sakarya Mantar, Timur Salincakli Casper

Greece

Iceland

Italy

Lebanon



Dimitris Christodoulakis Independent, Gulli Briem Mezzoforte, Keli Guðjónsson Agent Fresco, Johann Hjorleifsson, Giovanni Giorgi Independent, Alfredo Golino, Christian Mayer Independent, Lele Melotti, Georges Barbar Independent, Gio Najarian Independent

Morocco

Netherlands

Nigeria

Norway

Portugal

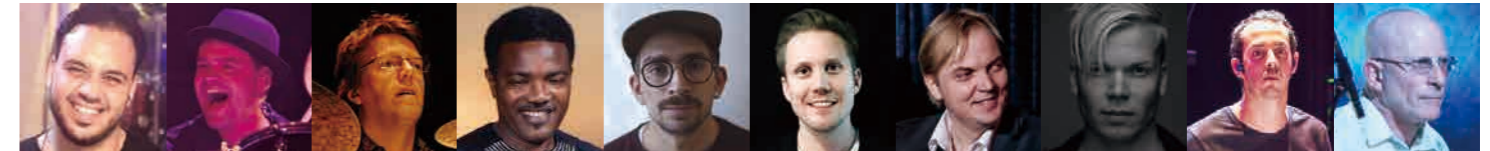

Amine Hasnaoui Independent, Oscar Kraal Miow, Ron van Stratum Randy Brecker, Robben Ford, Adewale Simeon Adeyemi Independent, Andreas Kjol Berg, Åsmund Knutson MD Norwegian Idol, The Voice Norway and Strictly Come Dancing Norway, Erik Smith Independent, Stig L. Vaernes Gabrielle, Nico & Vinz, Independent, Gustavo Gonçalves, Michael Lauren Educator

Slovakia

Spain



Guilherme Silva, Joel Silva, Martin Valihora Hiromi Uehara, Mezzoforte, Ramon Angel Rey Jazz Educator, Patti Ballinas Session drummer, Pedro Barceló Joaquín Sabina, Ketama, Studio, José Bruno Lelva, Calamaro, Fito, Studio, Diego Contreras Apache, Deivhook Kitai, Paco Garcia Session drummer

Sweden



Coki Giménez Dani Martin, M-Clan, Amaral, Studio, Lucas Jiménez Mr Online Drums TV, Miguel Morales Educator, Yoel Páez Berkelee Valencia, Xavier Reija David Bustamante, Book author, Manuel Reina Vanesa Martín, Miguel Poveda, Gustavo Segura Jose Andrea, Jairo Ubiña Gloria Gaynor, Tini, Abraham Mateo, Clinician, Matt de Vallejo Andy & Lucas, Mónica Naranjo, Clinician, Pelle Alsing Roxette

Sweden



Robban Bäck (W.E.T., Sabaton), Måns Block (Timbuktu & Damn!), Robert Mehmet Ikiz (Sabaton), Hannes Van Dahl (Sabaton), Harry Wallin (Hoffmaestro & Chraa), Joakim Wallin (Miriam Bryant), Nicki Wicked (Crucified Barbara), Martin Kissling (Anshelle), Dimitri Monstein, Volkan Oektem (Tarkan)

Switzerland

Turkey

Argentina



Leonardo Alvarez (Secion), Leo De Cecco (Ataque 77), Daniel Piazzolla (Escalandrum), Fernando Samalea (GUSTAVO CERATI, CHARLY GARCIA), Leandro Savelon (El Cuatrillo), Palín Sosa (Los Nocheros), Mark Charters (TSMOR, Freelance, Theatre), Jeff Consi (The Badloves), Toby Dundas (The Temper Trap), Ben Ellingworth (ILLY)

Australia



Joel Farland (Independent), Amy Findlay (STONEFIELD), Andy Fisenden (Independent), Leigh Fisher (Independent), Kristian Hopes (Grinspoon), Dave Jenkins (Independent), Lee Maloney (Diesel, Ghostwriters), Perrin Moss (Hiatus Kaiyote), Steve Pinkerton (Dallas Crane), Gordan Rytmeister (Independent)

Brazil

Indonesia



Shane Wakker (Bodyjar), ADAM WESTON (Birds Of Tokyo), Paul Wheeler (Independent), Cristiano Galvão (Independent, Simone), Cleverson Silva (Independent, The Voice Brasil), Rio Alief (Independent), Rosi Amrina (The Angels Percussion), Uzie Anggana (The Angels Percussion), Alvin Eka Putra (NOXA, DEADSQAD), Eno Gitar Ryanto (NTRL)

Korea



Ray Prasetya (Independent), Agung Yudha Asmara (Dewa 19, Ari Lasso Band), Seulong Kim (Toxic), LEE Kuinam (Independent), Oh Jongdae (Trio works, Independent), Choi Hyunjin (SEOTALJI Band, Independent), Hwang Jungkwan (Hwang Jungkwan Trio, Independent), Lee Sangmin (Independent), Kim Seungho (IU, Independent), Son Star (Cherry Filter)

Malaysia

Mexico



Namgoong Yon (Independent), John Ashley Thomas (Independent), Azlan Rudy (POP Snuvit), Jerry Felix (Independent), Eduardo Carrillo (Agora), Gilberto Castillo (NUTS), Mauricio Clavería (La Ley), Elohim Corona (Moderatto, Gran Sur, Los Señores Del Blues), Mónica Del Valle (Independent), Mario García (Big Band Jazz de Mexico, Raul Diblasio)

Nicaragua

Russia

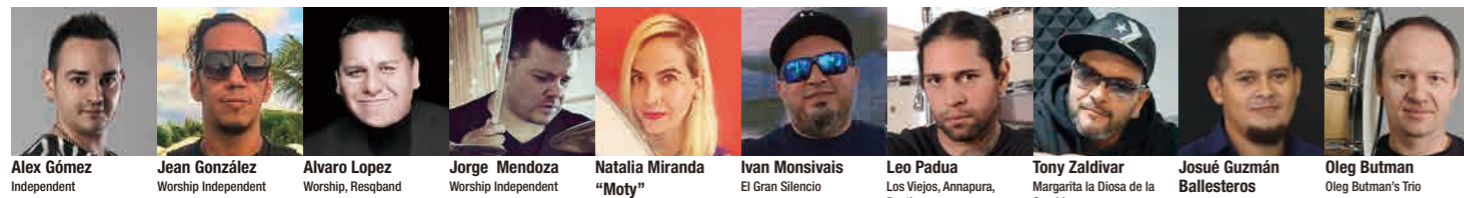

Alex Gómez (Independent), Jean González (Worship Independent), Alvaro Lopez (Worship, Resqband), Jorge Mendoza (Worship Independent), Natalia Miranda ("Moty" Independent), Ivan Monsivais (El Gran Silencio), Leo Padua (Los Viejos, Annapura, Bestia), Tony Zaldivar (Margarita la Diosa de la Cumbia), Josué Guzmán (Ballesteros Sincodigo), Oleg Butman (Oleg Butman's Trio)

Russia



Greg Karpov (5DIEZ), Max Klots (Paradigma), Dmitry Krivenkov (Epidemia), Sasha Mashin (Alex Sipiagin Quartet, Elenkrig Crew, Isfar Sarabski), Alexander Schigolev (Saverny Flot), Vladimir Zhurkin (Lundstrem Jazz Orchestra), Tim Ivanov (Sergei Lazarev), Mikhail Kozodaev (Noize MC, Timur Rodriguez, Independent Inova), Er Chow Kiat, Jimmy Lee (Independent)

Singapore

Taiwan

Thailand

Ukraine

Venezuela



Rafael Lee (D.O.M.S.), Jim Wei (Soda Green), Feng Yi Chou (Independent), Aekpong Cherdtham (Crescendo), Sutipong Pankong (Infinity), Pakpoom Watweingkam (Exotic), Weerachat Premananda (Skykick Ranger), Andrey Kuzmenchuk (Independent), Alexander Lyulyakin (Boombox), Miguel Hernandez (Independent)

Japan

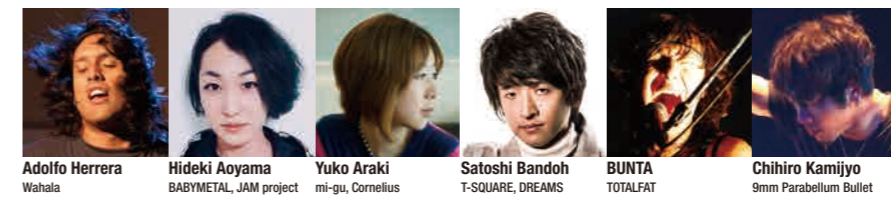

Adolfo Herrera (Wahala), Hideki Aoyama (BABYMETAL, JAM project), Yuko Araki (mi-gu, Cornelius), Satoshi Bandoh (T-SQUARE, DREAMS COME TRUE), BUNTA (TOTALFAT), Chihiro Kamijyo (9mm Parabellum Bullet)



Masahiko Osaka (Independent), SATOKO (FUZZY CONTROL), Kiyohiko Semba (Independent), Eiji Shimamura (Miyuki Nakajima), Kozo Suganuma (Independent)

- USA**
Carl Albrecht
Alex Alexander
Horace Arnold
Sergio Bellotti
Doug Belote
Michael Bland
Bogie Bowles
Mike Braun
Robert Breithaupt
JC Bryant
Obed Calvaire
Jim Campbell
Gary Chaffee
Vince Cherico
Leroy Clouden
Charles Collins
Glendon Crain
Dennis Davis
Marc Dicciani
Kimati Dinizulu
Peter Donald
Lorraine Faina
Gregg Field
Abe Fogle
Brian Fullen
Dick Gay
Robbie Gonzalez
MB Gordy
Art Gore
Michael Gould
Donny Gruendler
Jamey Haddad
Dana Hall
Marvin (Slam G's)
Hammett
Ivan Hampden
Tommy Harden
Dave Harrison
Brendan Hill
Gary Hobbs
Robin Horn
- Steve Houghton**
Andy Hubbard
Brian Ireland
Ralph Johnson
Jimmy Keegan
Mike Kennedy
Tom Knight
Karl Latham
Larry Lelli
Larry Levine
Chris Lukes
Craig Macintyre
John Mahon
David Mancini
Sherrie Maricle
Nick Mason
Dave McAfee
Sean McCurley
Scott Mercado
Rich Mercurio
Moke
T.S. Monk
Rick Montalbano
Richie Morales
Jack Mouse
Xavier Muriel
Jim Petercsak
Marcus Randolph
Ben Riley
Calvin Rodgers
Charles Ruggiero
Keith "Stix"
Mojmjon
Allan Schwartzberg
George Schwindt
Herb Shucher
Joe Sirois
Ed Soph
David Stanoch
John "Jabo" Starks
Joel Stevenett
Akira Tana
- Donald Tardy**
Jason Thomas
Dave Tull
Tony Verderosa
Brian Viglione
Chris Vrenna
Rodrigo Villanueva
Nick Vincent
Jamire Williams
Lonnie Wilson
Todd Wolf
- AUSTRALIA/
NEW ZEALAND**
Dave Haley
- CANADA**
Johnny Andrews
Dale Ann Brendon
Jayson Brinkworth
Yanic Bercier
Ben Bradley
Rob Brown
Jeff Brown
Flavio Cirillo
Jay Deachman
Morgan Doctor
Adam Dowling
Merlin Ettore
Dale Harrison
Mike Harshaw
Brad Kilpatrick
Mercedes Lander
Wilson Laurencin
Chris MacNeill
Gabe Mantel
Marito Marques
Andrew "Marty"
Martino
Chad Melchert
Mike Michalkow
Maya Miller
Mark Rogers
- CUBA**
Samuel Formell
- FRANCE**
Jean Baptiste Cortot
Nicolas Courret
Anne Pacéo
- GERMANY**
Lukas Berg
Jens Carstens
Josi Copolla
Dirk Erchinger
Mario Garruccio
Michael Grabinger
Herb Joesch
Patrick Metzger
- IRELAND**
Caroline Corr
- Netherlands**
Gregory Panthoffat
Gregory Pataca
Lean Robbemont
Dennis van Hoorn
Hans van Oosterhout
Hans vd Hurk
Jimmy vd Nieuwenhuizen
- SCANDINAVIA**
Ian Haugland
- SPAIN**
Javier Reija
- UK**
Ben Carrigan
Aled Richards
Chuck Sabo

Index

ARTISTS

Drummers in the World..... 1

SYSTEM DRUMS

- PHX Series 7
- Live Custom Hybrid Oak 11
- Recording Custom 15
- Absolute Hybrid Maple..... 19
- Tour Custom 23
- Stage Custom 25
- Stage Custom Hip 27
- Junior Kit 28
- Rydeen 29
- Snare Drums..... 31
- Technology 33

HARDWARE

- FP9 37
- Foot Pedal 39
- Hi-Hat Stand..... 41
- Cymbal Stand..... 43
- Snare Stand..... 45
- Stool 45
- Tom Holder 46
- Double Tom Stand..... 46
- HW3..... 47
- HEXRACK II..... 48
- EAD 49

DTX DRUMS

- DTX PAD..... 52
- DTX 402 Series..... 53
- DTX 502 Series..... 55
- DTX 700 Series..... 56
- DTX 900 Series..... 57
- Drum Trigger..... 58
- DTX-Multi 12 58
- Applications for DTX/EAD..... 59
- MODULE 61
- Pad 62
- Rack System 62
- Option..... 62

PHX Series

The PHX Series, from the Yamaha Drum Laboratory



Textured Black Sunburst

Shells
PHXB2218R PHXF1816 PHXF1615 PHXT1310 PHXT1209

Hardware
CH755 x 5 WS865 HS950 SS840 FP9315

*Cymbals are not included.
*Previous model hardware is shown in the photo.

Hybrid Shell Construction (U.S.PAT. 8022281)

With the wealth of knowledge that Yamaha has amassed through the decades as the preeminent maker of musical instruments, Yamaha's wood specialists have discovered new materials that provide optimal drum performance.

Jatoba, a Brazilian wood and the hardest material in the PHX hybrid shell, is positioned as the core ply and center note of the drum. It is surrounded on either side by layers of kapur, a Malaysian hard wood. North American Maple, which had long been considered a classic, high-quality drum shell material because of its hardness and viscosity, is actually the softest wood in the shell construction; maple is the outer and inner plies of the shell.

This is the process used to complete the hybrid shell, in which the stiffness of the shell shifts from the center toward the outside: the woods are hardest at the center and get softer toward the outer surfaces in either direction. This results in an "excitation structure" that maximizes the shell's performance. The excitation structure increases the head's vibration to its full extent, achieving a sound unlike anything you've heard before. It produces an effect in sound waves similar to rippling waves caused by a pebble dropped in water.

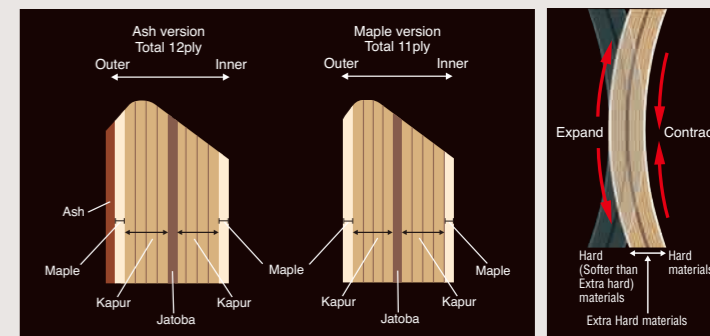

* The excitation structure increases shell vibration to its maximum through the use of relatively softer materials for the external and internal surface areas, whose curvature is greatest when the shell is vibrating, as well as by using a hard material with a high "spring" property for the core of the shell lamination.

YESSII Shell Mount System (U.S.PAT. 8168873)

YESSII shell mounting system acts as a shock mount system for the drum, allowing for optimal shell vibration.

Utilizing a unique rubber insert and a maple wood plate, the YESSII mount is primarily located at the nodal points (where no vibration occurs), causing the resonance to stay, within the shell as opposed to transferring through the hardware and being stifled.

In larger tom sizes, the rubber inserts are also positioned on the shell where overtones are present to help produce the appropriate mixture of sustain and overtone control.

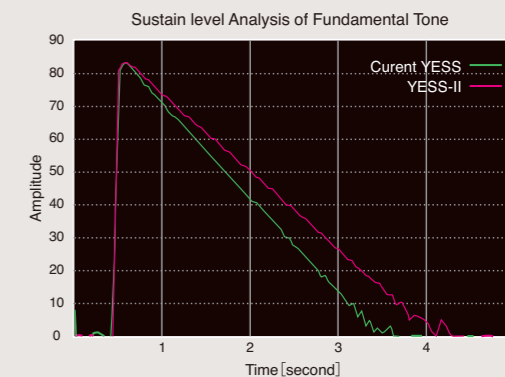
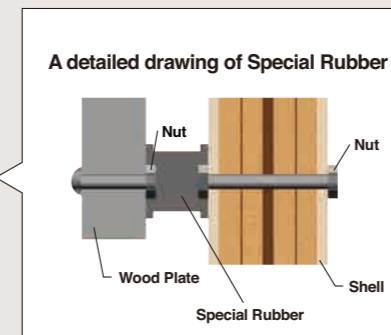
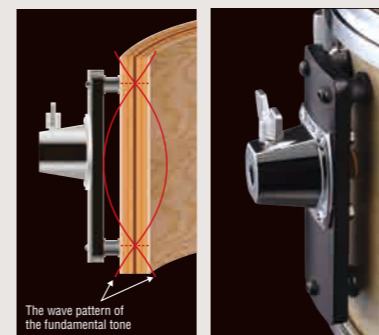

Hook Lug System (U.S.PAT. 7781658)

The Hook Lug system has emerged through the progression of the Nouveau Lug, which was an innovation in drum-lug design. This new lug minimizes the rotation of the lug casing during tuning and firmly supports the tuning bolt through the wide and straight post, even at high tension.

Rather than positioning the Hook Lug at the nodal point, Yamaha placed it at the area of the shell that produces undesirable overtones, thus muting them and allowing for an unobstructed, richer fundamental tone.

The combination of the Hook Lug system (muting the unattractive overtones) and the YESSII mount system (opening up the drum's fundamental tone) provides an unmistakably pure and naturally EQ'd sound. The organic tone of each drum is clear and perfectly defined like never before.



PHX Series

Shell	Shell Material	Hoop	Lug	Mount System	Clamp System	Tom Mount	Bass Drum	Head	BD	TT/FT
Air-Seal System	Hybrid Shell 11-ply	Aluminium Die-cast (3.0mm) (TT/FT) Wood Hoop BD	Hook Lug (Gold/chrome)	YESS II YESS (FT)	All Round Ball Clamp (Short Rod)	R-Version BD Tom Holder Bass BD	Bass Drum Legs	Batter/Top	Yamaha Remo Clear P3 18" BD Coated Ambassador	Yamaha Remo Clear Ambassador
								Front/Bottom	Yamaha Remo P3 Smooth White	Yamaha Remo Clear Ambassador

At Yamaha, prototype drums are the starting point of each drum's evolution.

These prototypes are created in the Drum Laboratory where Yamaha continually pursues the essence of musical perfection. Under a completely new concept, the PHX (pronounced "phoenix") Series is the pinnacle of excellence in this prototyping process. Handcrafted by our expert technicians, it's based on over 40 years of history, tradition, experience, and technology. PHX Series reveal Yamaha's all-out pursuit of the ultimate in drum craftsmanship and sound.



Polar White

- Shells**
 PHX2418MR x 2 PHXF1615M PHXF1413M PHXT1310M PHXT1209M
- Snare Drum**
 NSD1455
- Hardware**
 FP9500D x 2 HS1200T CS865 x 4 CH755 x 2 SS850 DS840 WS865A x 2

*Cymbals are not included.
 *Previous model hardware is shown in the photo.

A Range of Options

In addition to the qualities of tonality and functionality, Yamaha has paid special attention to the values of interior and exterior beauty. The exterior of the PHX shell is available in classic maple or exotic burl ash finishes. Further, the Hook Lugs and aluminum die-cast hoops are available in either gold or chrome options. Experience the ultimate combination of unparalleled beauty with brilliant color finishes, including the fresh and unique textured paint.



Bearing Edge Shape

To control the drum's tone and articulation, PHX floor tom, tom-tom and bass drum shells each use different types of bearing edges. All bearing edge angles are set at 30-degrees. However, the radiuses of the bearing edges differ to gain optimum acoustic performance from the shell. Additionally, a secret treatment process is used to ensure that each edge is finished to a perfect smoothness. This guarantees a very easy and wide tuning range.

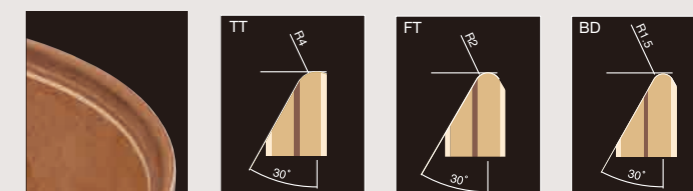

Color Finishes

ASH			MAPLE		3 types of surface finish
Gloss Finish	Textured Finish	Gloss Finish	Matte Finish		
Sapphire Fade (SPF)	Turquoise Fade (TQF)	Textured Black Sunburst (TBS)	Black Cherry Sunburst (BCS)	Matte Black (MBL)	
Garnet Fade (GNF)	Textured Amber Sunburst (TAS)	Polar White (PWH)	Matte Natural (MNT)		

Components

Diameter	Bass Drum						Bass Drum (R Version - without Pipe Clamp)						
	24"		22"		20"		18"		24"		22"		20"
x Depth	18"	16"	18"	16"	18"	16"	14"	18"	16"	18"	16"	18"	16"
Model No.	PHXB2418	PHXB2416	PHXB2218	PHXB2216	PHXB2018	PHXB2016	PHXB1814	PHXB2418R	PHXB2416R	PHXB2218R	PHXB2216R	PHXB2018R	PHXB2016R
No. of Tuning Bolts	10	10	10	10	10	10	8	10	10	10	10	10	10

Diameter	Floor Tom				Tom Tom														
	18"	16"	14"	16"	14"	13"	12"	11"	10"	9"	9"	12"	8"	8"	10"	7"	8"	8"	7"
x Depth	16"	15"	13"	14"	13"	12"	11"	10"	9"	9"	9"	8"	8"	8"	7"	7"	8"	8"	7"
Model No.	PHXF1816	PHXF1615	PHXF1413	PHXT1614	PHXT1613	PHXT1412	PHXT1411	PHT1310	PHXT1309	PHXT1209	PHXT1208	PHXT1008	PHXT1007	PHXT0808	PHXT0807				
No. of Tuning Bolts	8	8	8	8	8	8	8	6	6	6	6	6	6	5	5				

(Unit: inch)

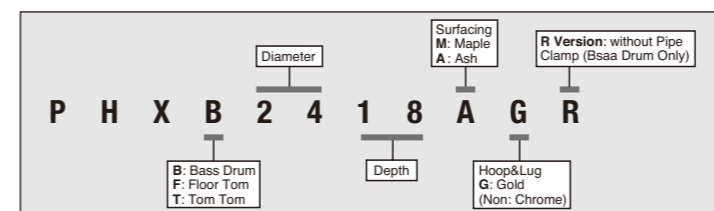

LIVE CUSTOM HYBRID OAK

Naturally Massive

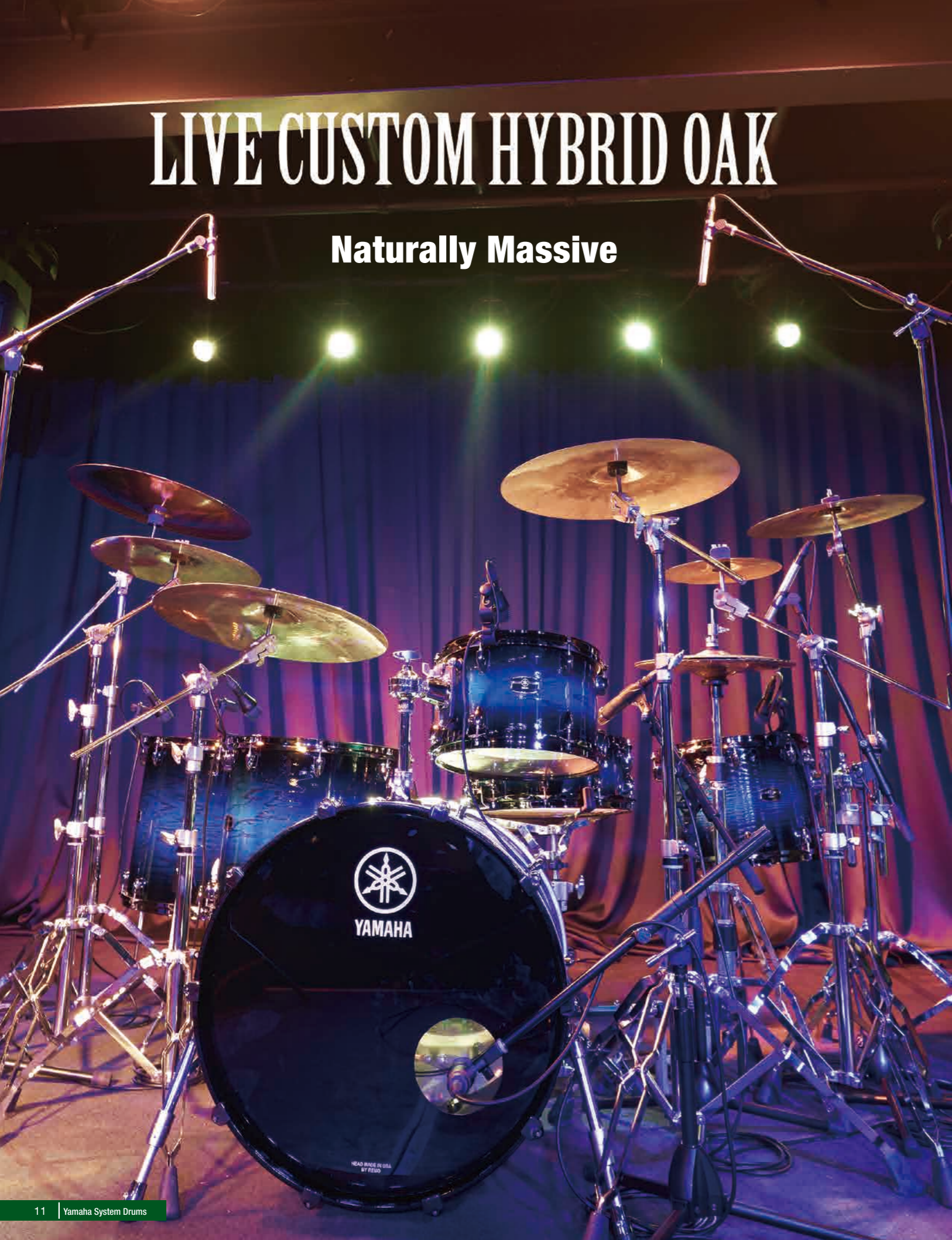

UZUKURI Finish

The traditional Japanese technique known as “UZUKURI” has been modified for use on drum shells. In this procedure, the soft areas in the wood grain are sanded and then the whole shell is coated with a thin layer of black paint. The entire surface of the shell is then sanded again before the final coating is applied, in a process that emphasizes the natural beauty of the Oak grain.

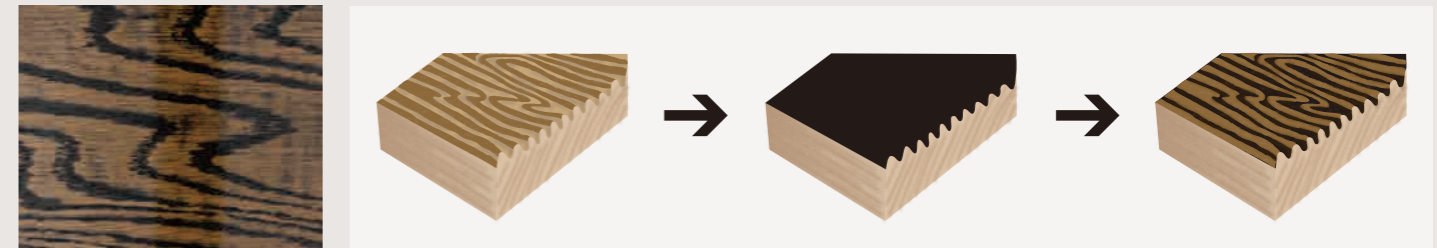

Oak/Phenolic Sheet Hybrid Shell (PAT.PEND)

The Live Custom Hybrid Oak shell concept is borrowed from our flagship PHX and Absolute Hybrid Maple kits, which feature a dense phenolic sheet sandwiched between two sheets of Oak ply. Always a pioneer in the field of Oak drums, Yamaha has enhanced the dynamic range of the new Live Custom kits by accentuating their attack and projection.

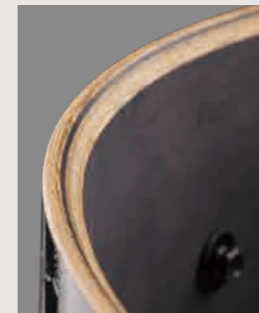

Bass Enhancement Weights (PAT.PEND)

Featuring a design styled around the Absolute Lug, the weights studded in the bass drum at the lug points attenuate low-mid frequencies, resulting in a tight, focused bass drum sound.

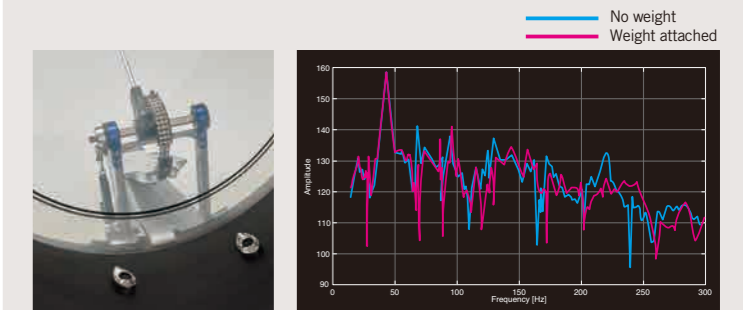

Features



Dark Silver Hardware and Black Finished Shell Interiors

Dark Silver hardware delivers a dominating image further heightened with the all black shell interiors.

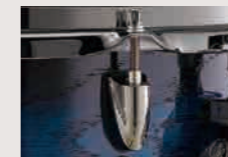

Absolute Lugs

Shells feature Yamaha's exclusive Absolute Lugs. Their sophisticated design adds a touch of class to the drums.



Die-Cast Bass Drum Hooks

Bass drums feature designed die-cast hooks, which provide noise free function through the use of an insertion plate.



Floor Tom Brackets

Floor Tom Bracket includes wing bolts. It's designed to clamp tightly on the leg without damaging it, to save time on stage, and to deliver optimum decay control.

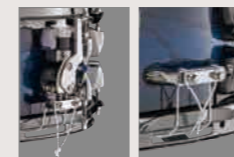

Q-Type Strainer

The heavy-duty Q-type strainer is robust offering solid and stable operation, along with adjustment and snare replacement.

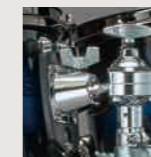

YESS III Mount

An evolutionary step up from our YESS II m tom mount, the YESS III reduces acoustic dampening even further. Allowing the shell to vibrate more freely, the YESS III mount brings out more of the shell's natural sustain and volume.



2.3mm Dyna Hoop

Thicker steel hoops offer a tighter sound and sharper response.

LIVE CUSTOM HYBRID OAK

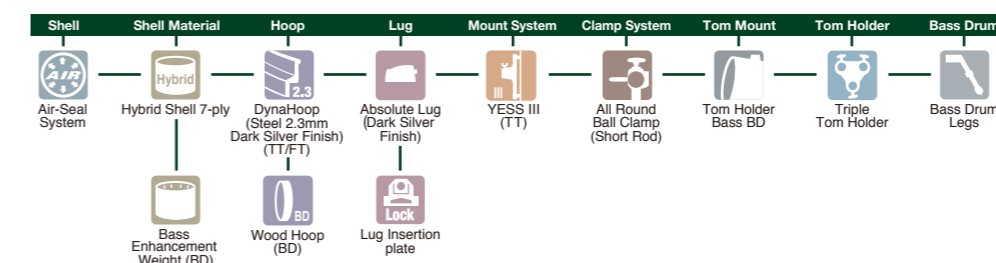

Head	20"-24" BD	18" BD	TT/FT
Batter/Top	Yamaha Remo P3 Clear	Yamaha Remo Coated Ambassador	Yamaha Remo Clear Emperor
Front/Bottom	Yamaha Remo P3 Ebony	Yamaha Remo P3 Ebony	Yamaha Remo Clear Ambassador

UZU Ice Sunburst

- Shells
LHB2416 LHF1816
LHF1615 LHT1411
- Snare Drum
LHS1455
- Hardware
CS865 x 4 HS1200
SS850 x 2 FP9C

*Cymbals are not included.



UZU Charcoal Sunburst

- Shells
LHB2218 LHP6F3
(LHF1615 LHT1208 LHT1007 TH945B)
- Snare Drum
LHS1455
- Hardware
CS865 x 3 HS1200
SS850 FP9C

*Cymbals are not included.



UZU Earth Sunburst

- Shells
LHB2016 LHP4F3
(LHF1413 LHT1208 LHT1007 TH945B)
- Snare Drum
LHS1455
- Hardware
HW3 (CS3 x 2, HHS3, SS3)
CS3 FP7210A

*Cymbals are not included.



UZU Natural

- Shells
LHB1814 LHF1413 LHT1208
- Snare Drum
LHS1455
- Hardware
HW3 (CS3 x 2, HHS3, SS3)
CL945LB FP7210A

*Cymbals are not included.



Snare Drums

LHS1455
Size 14" x 5.5"



Color Finishes



UZU Ice Sunburst (UIS)



UZU Magma Sunburst (JMS)



UZU Natural (UNT)



UZU Earth Sunburst (UES)



UZU Charcoal Sunburst (UCS)

Natural colors found in UZUKURI finishes may vary depending upon the character and grain of the shell's wood.

Components

	Bass Drum					Floor Tom			Tom Tom				Snare Drum	
Diameter	24"	22"	22"	20"	18"	18"	16"	14"	14"	13"	12"	10"	8"	14"
x Depth	16"	18"	16"	16"	14"	16"	15"	13"	11"	9"	8"	7"	7"	5.5"
Model No.	LHB2416	LHB2218	LHB2216	LHB2016	LHB1814	LHF1816	LHF1615	LHF1413	LHT1411	LHT1309	LHT1208	LHT1007	LHT0807	LHS1455

(Unit: inch)

Tom Packages

	Floor Tom	Tom Tom		Tom Holder
LHP6F3	LHF1615	LHT1208	LHT1007	TH945B
LHP4F3	LHF1413	LHT1208	LHT1007	TH945B

Recording Custom

The Most Recorded Sound Ever

The Recording Custom drum kit has a short decay and quick attack, and there is no interference from other instruments or from within the drum kit itself. Its clarity of sound has won this kit the trust of drummers and engineers alike. The Recording Custom drum kit is prized first and foremost by studio musicians, who fell in love with its sound, and it has been used in many famous songs in the decades since its launch. It is still actively used in recording today and continues to be loved by many. This legendary kit set the standard for studio recording, and as a result has become the quintessential drum sound for listeners around the world.



Lifted Style Bass Drum

Steve prefers a 20 inch lifted bass drum, so we adopted this specification. We reduced interference from the floor to maximize the resonance of the shell, and increased the length of the pedal beater rod, centering it precisely to ensure absolute accuracy during performances. This lifted bass drum produces a more punchy sound and accentuates the sound produced in the core of the shell.



New Weighted High Tension Lugs

The revamped modern design retains the traditional essence of the Recording Custom. In order to maximum the attenuating properties of the birch wood, we've increased the weight of the lug, further enhancing the artist's expressive power and reducing undesirable noise from the shell without using a mute. This ensures optimum sustain for the core sound, producing a crisp, articulate tone.



Snare Drums

RBS1455
Size 14"x 5.5"



RBS1480
Size 14"x 8"



Color Finishes



Solid Black (SOB)



Classic Walnut (WLN)



Real Wood (RW)



Surf Green (SFG)

YESS Mount

The set angle of Yamaha's original ball mount and clamp can be adjusted over a full range of motion.

With the internal hard synthetic resin balls stabilizing the mount, you can set the drum to any angle, maintaining excellent stability and precise location control simply by tightening the steel plate with the large wing nut.

The tom holders produced by other companies have a vertical bar running through the center, preventing drummers from pulling the drum toward or pushing it away from themselves. Such tom holders only permit the position of the toms to be changed, which in turn alters the position of the bass drum, giving the flexible Yamaha tom holder a clear advantage over the competition.



All Birch Shell

In addition to their punchy power, birch shells are known to reduce unwanted noise and prevent interference when drums are set up side-by-side. The unique sonic characteristics of birch wood ensure that each stroke is clearly delineated, making it widely considered to be the ideal choice for recording environments.



Components

	Bass Drum						Floor Tom						Tom Tom						Snare Drum	
Diameter	24"	22"	22"	22"	20"	18"	18"	16"	14"	16"	14"	13"	13"	12"	12"	10"	10"	8"	14"	14"
x Depth	14"	18"	16"	14"	16"	14"	16"	15"	13"	14"	12"	11"	9"	10"	8"	9"	7.5"	7.5"	5.5"	8"
Model No.	RBB2414	RBB2218	RBB2216	RBB2214	RBB2016	RBB1814	RBF1816	RBF1615	RBF1413	RBT1614	RBT1412	RBT1311	RBT1309	RBT1210	RBT1208	RBT1009	RBT1007	RBT0807	RBS1455	RBS1480
No. of Tuning Bolts	10	10	10	10	10	8	8	8	8	8	8	6	6	6	6	6	6	5	10	10

Surf Green

- Shells
RBB2218
RBP6F3
(RBF1615 RBT1208 RBT1007 TH945B)
- Snare Drum
RBS1455
- Hardware
CS865 x 3 HS1200T
SS950 FP9500C

*Cymbals are not included.



Solid Black

- Shells
RBB2216
RBP6F3
(RBF1615 RBT1208 RBT1007 TH945B)
- Snare Drum
RAS1455
- Hardware
CS865 x 3 HS1200T
SS950 FP9500C

*Cymbals are not included.



Classic Walnut

- Shells
RBB2414
RBF1615 RBF1816 RBT1309
- Snare Drum
RRS1465
- Hardware
CS865 x 4 HS1200T
SS950 FP9500C
SS850

*Cymbals are not included.



Real Wood

- Shells
RBB2216
RBP6F3
(RBF1615 RBT1208 RBT1007 TH945B)
- Snare Drum
RBS1455
- Hardware
CS865 x 3 HS1200T
SS950 FP9500C

*Cymbals are not included.



Refining the legendary RC with Steve Gadd

For the past 3 years I've been meeting with the Research and Development guys at Yamaha with the aim of bringing the Recording Custom Series up to date. I told Yamaha what I thought throughout the process; the result is that everything is a step up. They still feel like the Recording Custom, when you take them out of the box they don't feel new, they feel comfortable and I think that's good. The Bass Drum has a nice fat sound, the drum responds to different heads on it, and my goal was to have a simple Snare Drum design that could respond to a wide range of tuning. I think we did a great job, the new Recording Customs sound great and I think you'll like them.



Tom Packages

	Floor Tom	Tom Tom	Tom Holder
RBP6F3	RBF1615	RBT1208	RBT1007 TH945B
RBP4F3	RBF1413	RBT1208	RBT1007 TH945B

RECORDING CUSTOM

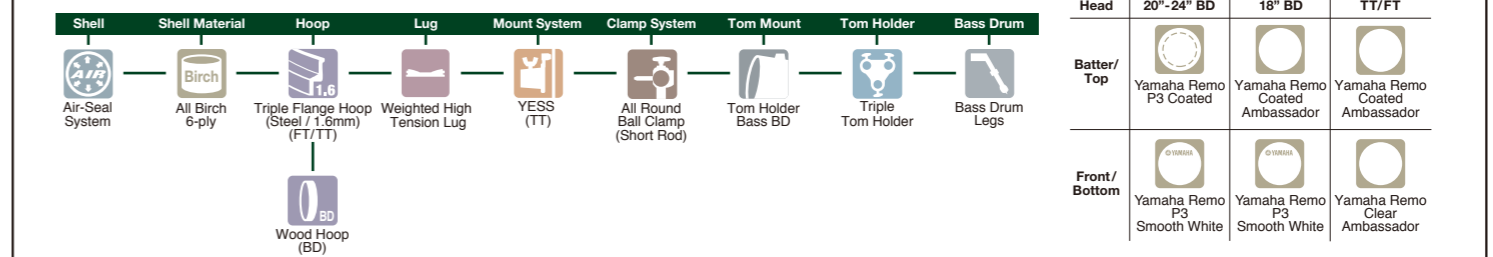

Absolute

HYBRID MAPLE



Pursuing Expressive Drums

What Defines “Expressive” Drums?

The answer to that question, we feel, are drums that give you the sound you need, whenever you need it. Tonal requirements vary among drummers, differ with dynamics, and change, from band to band, song to song, moment to moment. With the Absolute Hybrid Series drums, Yamaha has succeeded in addressing this, with a drum set that possesses an extraordinary degree of expressive power, allowing drummers to pursue a level of expression that perhaps they’ve not experience before in their other drums. These drums offer a wide dynamic range that allows them to respond accurately to each and every stroke, and follow changes in dynamics, nuance, and touch, letting you play what you want to play.

Hybrid Maple Shells

The Absolute Hybrid Series inherits the hybrid shell technology found on our flagship PHX Series. On Absolute Hybrid shells, the design consists of a core ply of wenge a very hard and heavy wood native to Africa, sandwiched between plies of North American Maple, well known for its clear tone. This hybrid design delivers a drum tone that plays rich and clear across the full dynamic range, from pianissimo to fortissimo.

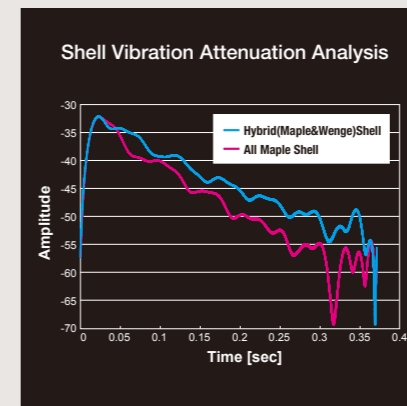

Bearing Edge Shape

The bearing edge angle on the bass drum differs from the angle used on the tom and snare shells to optimize tonal balance in the drum set. A 45°/R1.5 edge is used on the snare and toms to a balanced tone; while a 30°/R1.5 edge on the bass drum shell brings out more low-end tone for a deeper, more powerful sound.

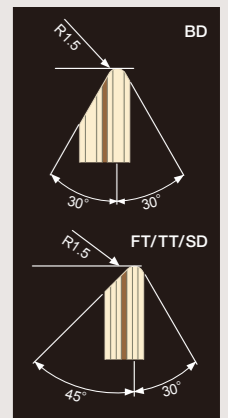

YESS III Tom Mount

An evolutionary step up from our YESS II tom mount, the YESS III reduces acoustic dampening even further. Allowing the shell to vibrate more freely, the YESS III mount brings out more of the shell's natural sustain and volume.

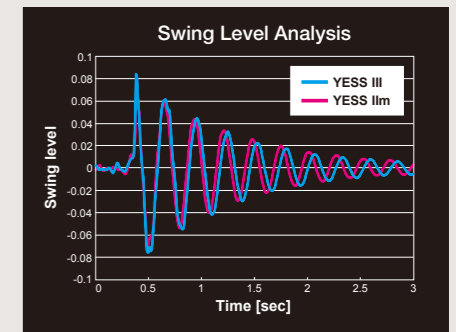

YESS III mount realizes longer sustain level, because it holds shell more flexibly, makes shell swing slower than YESS II and not prevent natural sustain.

Features

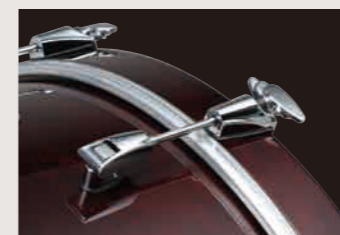

Hook Lugs
Hook lugs offer quick and easy head replacement, precision tuning, and can readily handle high-tension tuning. Lug bases are designed with a small footprint to maximize tone output from the hybrid shell.



Floor Tom Bracket
Floor tom brackets offer smooth height replacement, precision tuning, and can readily handle high-tension tuning. Lug bases are designed with a small footprint to maximize tone output from the hybrid shell.



Low-Mass Tom Holder Base
The tom holder's light weight and small footprint allows the bass drum shell to vibrate more freely.



3.0mm Aluminum Die-Cast Hoops
Aluminum die-cast hoops deliver a strong tight sound with an extraordinary attack and decay.



Q-Type Strainer
The heavy-duty Q-type strainer is robust offering solid and stable operation, along with adjustment and snare replacement.



Vent Holes
Controlling the amount of air moving in and out of the shell has a great influence on the drum's tone and sustain length, so the number of holes incorporated on the Absolute Hybrid's various shells is determined by the size of the shell's diameter.

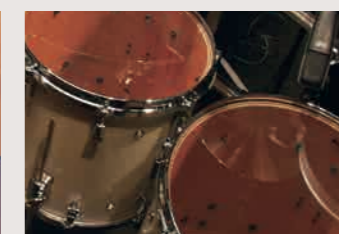

Interior Vintage Finish
Shell interiors are coated with our exclusive Vintage Natural finish for enhanced tone and refined looks.

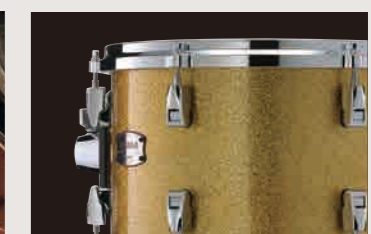

Color Finishes
A rich lineup of color finishes includes a traditional vintage natural, solid black, and selection of ultra-fine flake sparkle finishes that show Yamaha's exceptional skills at creating gorgeous finishes.

Pink Champagne Sparkle

- Shells
AMB2214
AMP4F3
(AMF1413 AMT1208 AMT1007 TH945B)
AMF1615

- Snare Drum
AMS1460

- Hardware
DFP9500C HS1200T CS865
DS840 CH750

*Cymbals are not included.



Orange Sparkle

- Shells
AMB2218
AMP6F3
(AMF1615 AMT1208 AMT1007 TH945B)

- Snare Drum
AMS1460

- Hardware
HW780
(FP7210A HS740A CS755 x 2 SS740A)
DS840

*Cymbals are not included.



Color Finishes



Vintage Natural (VN)



Classic Walnut (WLN)



Red Autumn (RAU)



Solid Black (SOB)



Polar White (PWH)



Jade Green Sparkle (JGS)



Orange Sparkle (ORS)



Gold Champagne Sparkle (GCS)



Pink Champagne Sparkle (PCS)



Silver Sparkle (SLS)

Tom Pack System — Build The Kit That Fits You Best

Putting together a drum kit that lets you sound and play the way you want can be difficult. But the Live Custom Tom Pack System makes the process much easier. Follow the three easy steps to create the kit that fits your needs.

1. Deciding on the bass drum size

Bass drum shells are available in seven different sizes to meet player demands for a variety of music styles. The most popular shell, the 22-inch, is offered in three different depths, 14-, 16-, and 18-inch.

Bass Drum



2. Next, choosing the floor tom size

Two Absolute Hybrid Maple tom packs are available, each equipped with two tom-toms and a floor tom. Tom packs come complete with a tom holder so you'll have a full set of drums when combined with your choice of a bass drum and snare.

AMP4F3

Floor Tom: AMF1413
Tom Tom: AMT1007, AMT1208
Tom Holder: TH945B

AMP6F3

Floor Tom: AMF1615
Tom Tom: AMT1007, AMT1208
Tom Holder: TH945B

3. Finally, select a snare drum, additional toms and a floor tom

Customize your kit with a snare drum or different size toms, or an additional floor tom.

Snare Drum

AMS1460
Size 14" x 6"



Floor Tom

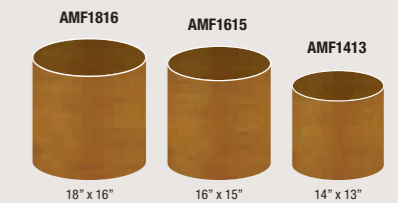

AMT 1208 and AMT1007 are included in the Tom Pack.

Tom Tom

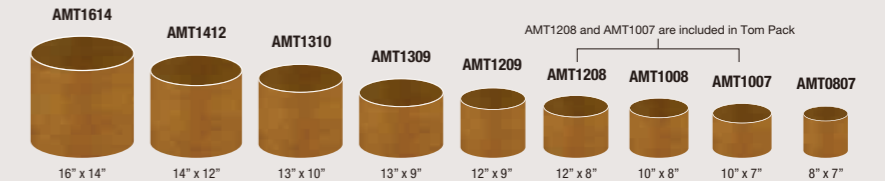

Of course you can select shells individually and create a combination that suits your specific musical tastes and needs.

ABSOLUTE HYBRID MAPLE

Component	Head	20"-24" BD	18" BD	TT/FT
Shell	Air-Seal System	Hybrid	Aluminum Die-cast (3.0mm)	Wood Hoop BD
Shell Material	Hybrid Shell 7-ply 7-ply/8.0mm (BD) 7-ply/6.2mm (TT/FT)			
Hoop				
Lug	Hook Lug			
Mount System	YESS III (TT)			
Clamp System	All Round Ball Clamp (Short Rod)			
Tom Mount	Tom Holder Bass BD			
Tom Holder	Triple Tom Holder			
Bass Drum	Bass Drum Legs			
Batter/Top	Yamaha Remo P3 Clear	Yamaha Remo Coated Ambassador	Yamaha Remo Clear Emperor	
Front/Bottom	Yamaha Remo P3 Smooth White	Yamaha Remo P3 Smooth White	Yamaha Remo Clear Ambassador	

Components

	Bass Drum							Floor Tom		
	24"	24"	22"	22"	22"	20"	18"	18"	16"	14"
Diameter	24"	24"	22"	22"	22"	20"	18"	18"	16"	14"
x Depth	16"	14"	18"	16"	14"	16"	14"	16"	15"	13"
Model No.	AMB2416	AMB2414	AMB2218	AMB2216	AMB2214	AMB2016	AMB1814	AMF1816	AMF1615	AMF1413
No. of Tuning Bolts	10	10	10	10	10	10	8	8	8	8

	Tom Tom								
	16"	14"	13"	13"	12"	12"	10"	10"	8"
Diameter	16"	14"	13"	13"	12"	12"	10"	10"	8"
x Depth	14"	12"	10"	9"	9"	8"	8"	7"	7"
Model No.	AMT1614	AMT1412	AMT1310	AMT1309	AMT1209	AMT1208	AMT1008	AMT1007	AMT0807
No. of Tuning Bolts	8	8	6	6	6	6	6	6	5

Tom Packages

	Floor Tom	Tom Tom	Tom Holder
AMP6F3	AMF1615	AMT1007	AMT1208
AMP4F3	AMF1413	AMT1007	AMT1208

*Availability of some models is limited.

(Unit: inch)

TOUR CUSTOM ALL MAPLE SHELL

Caramel Satin

- Shells
TMP2F4
BD22" x 16" FT16" x 15" TT12" x 8"
TT10" x 7" TH945C
- Snare Drum
TMS1455
- Hardware
CS865 x 3 HS850 SS850
FP9500C

*Cymbals are not included.

World Touring is OUR JAM

The world's largest touring and music festival supply companies state that Yamaha drums and hardware are the most requested and reliable available, which inspired our design team to create the TOUR CUSTOM MAPLE Traditional Satin series. Continuing the design legacy of our original Absolute Series, these new drums combines the projection and expressive capability of all-maple shells with the beautiful grain of US maple inside and out.



Candy Apple Satin

- Shells
TMP2F4
BD20" x 15" FT14" x 13" TT12" x 8"
TT10" x 7" TH945C
- Snare Drum
RLS1455
- Hardware
CS865 x 3 HS850 SS850
FP9500C

*Cymbals are not included.



Chocolate Satin

- Shells
TMP0F4
BD20" x 15" FT14" x 13" TT12" x 8"
TT10" x 7" TH945C
- Snare Drum
TMS1455
- Hardware
CS865 x 3 HS850 SS850
FP9500C

*Cymbals are not included.



Snare Drums

TMS1455
Size14" x 5.5"



TMS1465
Size14" x 6.5"



Color Finishes



Specifications

		Bass Drum	Floor Tom	Tom Tom
Shells	Thickness		5.6mm	
	Material		Maple (6ply)	
Bearing Edge			45 degrees	
Hoop	Material	Maple	Inverse Dyna Hoop	
	Thickness	8.0mm	2.3mm	
Lugs	Type	Absolute Lug (Chrome finish)		
Head	Top	-	REMO Clear Ambassador	
	Bottom	-	REMO Clear Ambassador	
	Front	Yamaha Remo UT P3 Smooth White	-	-
	Batter	REMO Powerstroke3 Clear	-	-
Tom Mount		YESS		

Shell Packages

	Bass Drum	Floor Tom	Tom Tom	Tom Holder
TMP2F4	22" x 16"	16" x 15"	12" x 8"	10" x 7" TH945C
TMP0F4	20" x 15"	14" x 13"	12" x 8"	10" x 7" TH945C

Components

	Floor Tom	Tom Tom	Snare Drum	
Diameter	14"	13"	5.5"	6.5"
x Depth	13"	9"	14"	14"
Model No.	TMF1413	TMT1309	TMS1455	TMS1465
No. of Tuning Bolts	8	6	10	10

(Unit: inch)

All Maple Shell (6ply-5.6mm/45 degree bearing edge)

All-maple shells give Tour Custom drums their warm, bright tone. These shells are designed with a 6 ply-5.6mm/45 degree bearing edge that adds the tonal depth, quick response and provides just the right amount of sustain. Finished with a beautiful satin lacquer (with all-new colors) that maximizes the sonic potential of the maple shell, Tour Custom drums sound great and play well in any musical style.



Yamaha Enhanced Sustain System - Y.E.S.S

YESS mounts are designed to minimize contact between the shell and the mount to deliver a wider dynamic range and longer sustain.



Inverse Dyna Hoop (2.3mm)

Newly designed 2.3mm Inverse Dyna hoop controls the natural overtones inherent to all-maple drums and focuses the fundamental tone of the shell.



Absolute Lugs

Shells feature Yamaha's exclusive Absolute Lugs. Their sophisticated design adds a touch of class to the drums.



4-piece Shell Pack with Triple Mount Tom Holder



TMP2F4
(22"x16" bass drum/16"x15" floor tom/12"x8" tom tom/10"x7" tom tom/tom holder [TH945C])
TMP0F4
(20"x15" bass drum/14"x13" floor tom/12"x8" tom tom/10"x7" tom tom/tom holder [TH945C])



TOUR CUSTOM

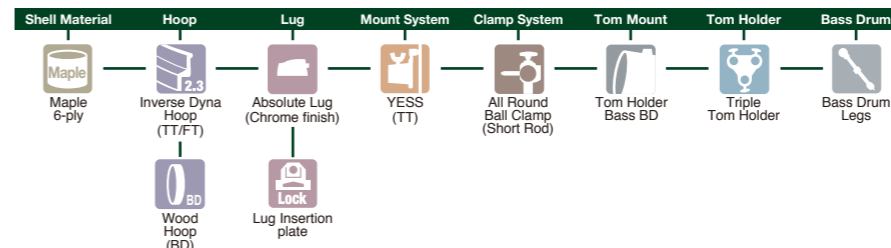

	20"-22" BD	TT/FT
Batter/Top	Remo P3 Clear	Remo Clear Ambassador
Front/Bottom	Yamaha Remo UT P3 Smooth White	Remo Clear Ambassador

STAGE CUSTOM

ALL BIRCH SHELL

100% Birch Shell Stage Custom has evolved again

As with the introduction of Stage Custom in 1995 Yamaha once again sets the standards of value and sound. By borrowing from our legendary Yamaha custom drums, we are proud to introduce new 100% Birch Shell Stage Custom.



Honey Amber

Shells

SBP2F5

SBB2217 SBF1615 SBT1208
SBT1007 SBS1455 TH945C

SBF1413 SBT0807

Hardware

DFP9500C HS1200T
CS865 x 4 SS950 DS840
CSAT924A CL945B
CH750

*Cymbals are not included.

Pure White

Shells

SBP0F5

SBB2017 SBF1413 SBT1208
SBT1007 SBS1455 TH945C

Hardware

HW780

FP7210A HS740A CS755 x 2
SS740A

*Cymbals and Drum stool are not included.



Bop Kit

Small-diameter 3-piece kit features 100% birch shells which delivers the Stage Custom sound without compromise. This is ideal for jazz, light session work, performances in small venues, and all-around second-kit use.



Kendrick Scott



Natural Wood

Shells

SBP8F3

SBB1815 SBF1413 SBT1208
CL945LB

Snare Drum

SBS1455

Hardware

HW680

FP6110A HS650A CS655Ax2
SS650A

*Cymbals and Snare Drum are not included.
*This drum features a coated head.
*Choose from three colors - RB, CR and NW.

Shell

The shell is a key factor in a drum's ability to "rumble," or resonate. Accordingly, the Stage Custom employs 100% birch - a classic in the realm of high-class drum kits. Moreover, with its six-ply structure the Stage Custom accurately conveys the vibrations produced at the impact surface, achieving performance that overwhelms anything in its class.

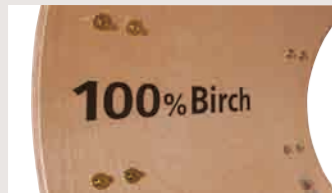

ALL BIRCH 6PLY

YESS Tom Mount



Attached at the drum's nodal point where shell vibration is least affected, Yamaha Enhanced Sustain System (YESS) minimizes lug to shell contact to increase resonance while maximizing dynamic range and sustain. YESS is also used on floor tom brackets to maximum sustain.

Separate Lug



Separate type lugs are designed with a small footprint that minimizes contact between the shell and lug to reduce dampening of shell vibration. An insertion plate set between metal parts and the shell isolates the metal parts from the wood further reducing dampening.

Color Finishes



Raven Black (RB)



Cranberry Red (CR)



Natural Wood (NW)



Honey Amber (HA)



Pure White (PW)

Snare Drums

SBS1455

Size 14" x 5.5"



SSS1455

Size 14" x 5.5"



SSS1465

Size 14" x 6.5"



Shell Packages

	Bass Drum	Floor Tom	Tom Tom	Snare Drum	Tom Holder	
SBP2F5	SBB2217	SBF1615	SBT1208	SBT1007	SBS1455	TH945C
SBP0F5	SBB2017	SBF1413	SBT1208	SBT1007	SBS1455	TH945C
SBP8F3	SBB1815	SBF1413	SBT1208	—	—	CL945LB

Components

	Bass Drum				Floor Tom			Tom Tom				Snare Drum			
	24"	22"	20"	18"	18"	16"	14"	14"	13"	12"	10"	8"	14"	14"	14"
Diameter	24"	22"	20"	18"	18"	16"	14"	14"	13"	12"	10"	8"	14"	14"	14"
x Depth	15"	17"	17"	15"	16"	15"	13"	11"	9"	8"	7"	7"	5.5"	5.5"	6.5"
Model No.	SBB2415	SBB2217	SBB2017	SBB1815	SBF1816	SBF1615	SBF1413	SBT1411	SBT1309	SBT1208	SBT1007	SBT0807	SBS1455	SSS1455	SSS1465
No. of Tuning Bolts	8	8	8	6	8	8	6	6	6	6	6	5	10	10	10

(Unit: inch)

STAGE CUSTOM

	Shell Material	Hoop	Lug	Mount System	Bass Drum	Clamp System	Tom Holder	Head	20"-24" BD	18" BD	TT/FT	Head	Bop Kit	
													BD	TT/FT
Batter/Top	Birch All Birch 6-ply	Triple Flange Hoop (Steel / 1.5mm) (FT/TT)	Separate Lug	YESS (TT)	Bass Drum Legs	All Round Ball Clamp (Short Rod)	Triple Tom Holder	Yamaha Remo UT P3 Clear	Yamaha Remo UT Coated Ambassador	Yamaha Remo UT Clear Ambassador	Yamaha Remo UT Coated Ambassador	Yamaha Remo UT Coated Ambassador	Yamaha Remo UT Coated Ambassador	Yamaha Remo UT Coated Ambassador
Front/Bottom	Wood Hoop (BD)	Lock Lug Insertion plate						Yamaha Remo UT P3 Ebony	Yamaha Remo UT P3 Ebony	Yamaha Remo UT Clear Ambassador	Yamaha Remo UT P3 Smooth White	Yamaha Remo UT P3 Smooth White	Yamaha Remo UT Coated Ambassador	Yamaha Remo UT Coated Ambassador

STAGE CUSTOM HIP

Hip is Where You Find it

NEW

Matte Surf Green

■ Shells
SBP0F4H
BD20" x 8" FT13" x 8" TT10" x 5" SD13" x 5"
CL940LB

■ Hardware
HW3
(CS3 x 2 HHS3 SS3)
FP7210A

*Cymbals are not included

A compact Stage Custom kit using the 100% birch shells that have become synonymous with Yamaha drums. A shallow bass drum measuring 20 x 8 inches supports the bottom-end of the band and keeps the overall setup compact. The floor tom is also equipped with snares to allow for use in a variety of different kinds of music.

20" x 8" Bass Drum

This kit combines the diameter used to achieve the rich bass tones of a regular set with a shallow body that allows the drummer to save space.



Compact Setting

Thanks to a bass drum that is thinner than usual, the Stage Custom Hip is compact enough to set up in even the smallest of venues.



Shell Package

	Bass Drum	Floor Tom	Tom Tom	Snare Drum	Tom Holder
SBP0F4H	20" x 8"	13" x 8"	10" x 5"	13" x 5"	CL940LB

STAGE CUSTOM HIP

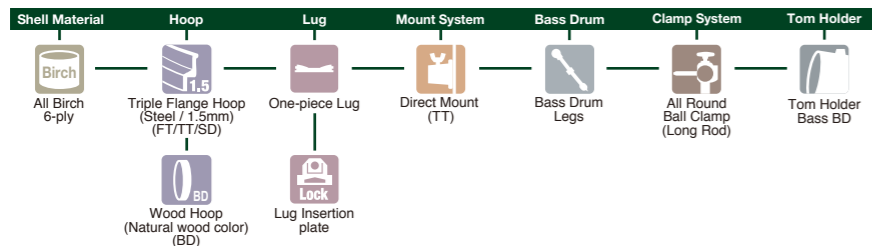

Head	BD	TT	SD/FT
Batter/Top	Yamaha Clear with ring mute	Yamaha Coated	Yamaha Coated
Front/Bottom	Yamaha Smooth White with ring mute	Yamaha Clear	Yamaha Snare Side

Junior Kit

Sound developed in collaboration with Manu Katche



Deep Violet

■ Shells
JK6F5
BD16" x 15" FT13" x 12" TT12" x 7"
TT10" x 7" SD12" x 5" TH940B

■ Hardware
HWJK
FP6110A HS650S CS651 x 2
SS662S
Tom Holder TH940B

*Cymbals are not included

Color Finishes



Deep Violet (DV) Cranberry Red (CR) Raven Black (RB)

Junior Kit hardware

Designed to be adjustable across a flexible range of heights, the Junior Kit's hardware has been simplified to provide just the functionality needed while retaining its existing solidity, resulting in a lightweight construction. One set fits in a single box, making it extremely portable.



Flexible kit height suitable for everyone from children to adults

The Junior Kit is comfortable for adults to play, while children can play it with ease when set to its lowest height. This flexible configuration makes the Junior Kit a joy to play for both adults and children across the globe, in any performance setting.



Small Kits with 2 toms

This kit features a two-tom layout, based on Manu Katche's desire to create a kit for use in educational settings where scores with two-tom notation are standard. Although a small-diameter kit, this configuration is useful for drummers all over the world, allowing them to play performances that conform to the common standard.



Sometimes great things come in small packages

Developed in collaboration with Manu Katche, the Junior Kit offers superior performance in a small diameter configuration that can be adjusted to a wide range of heights.



Set Lists

	Bass Drum	Floor Tom	Tom Tom	Snare Drum	Tom Holder
JK6F5	BD16" x 15"	FT13" x 12"	TT12" x 7"	SD12" x 5"	TH940B
HWJK	FP6110A	HS650S	CS651 x 2	SS662S	—

(Unit: inch)

JUNIOR KIT

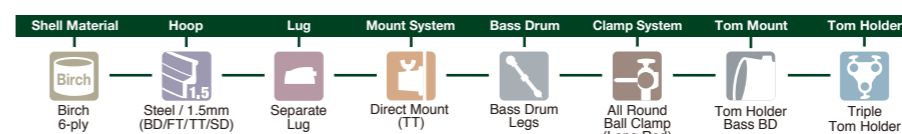

Head	16" BD	TT/FT
Batter/Top	Yamaha Clear with ring mute	Yamaha Clear
Front/Bottom	Yamaha Ebony with ring mute	Yamaha Clear

RYDEEN

make your thunder



Hot Red

Shells

RDP0F5

BD20" x 16" FT14" x 13" TT12" x 8"
TT10" x 7" SD14" x 5.5" CL940LB x 2

Hardware

HW680W

FP7210A HS650WA CS665A x 2
SS650WA

*Cymbals are not included



Burgundy Glitter

Shells

RDP2F5

BD22" x 16" FT16" x 15" TT12" x 8"
TT10" x 7" SD14" x 5.5" CL940LB x 2

Hardware

HW680W

FP7210A HS650WA CS665A x 2
SS650WA

*Cymbals are not included



Black Glitter

Shells

RDP2F5

BD22" x 16" FT16" x 15" TT12" x 8"
TT10" x 7" SD14" x 5.5" CL940LB x 2

Hardware

HW680

FP6110A HS650A CS665A x 2
SS650A

*Cymbals are not included

Genuine Yamaha tom and pipe clamps

Two 22.2 mm diameter tom clamps, and a pipe clamp. A versatile ball mount gives you the freedom to mount toms at any angle you want, and lets you incorporate other hardware* to create a configuration that's perfect for you.

* Hardware must conform to the standard Yamaha 22.2 mm specification.



CL940LB Tom Clamp

P3 type bass drum head

The double film on the edge section provides a muting effect, for a tight, powerful bass drum sound.



Color Finishes



Mellow Yellow (YL)



Hot Red (RD)



Silver Glitter (SLG)



Burgundy Glitter (BGG)



Black Glitter (BLG)

Setting Variations * Using Hardware sold separately.



Adding Cowbell Holder <CWH940>



Adding Cymbal Holder <CH755>

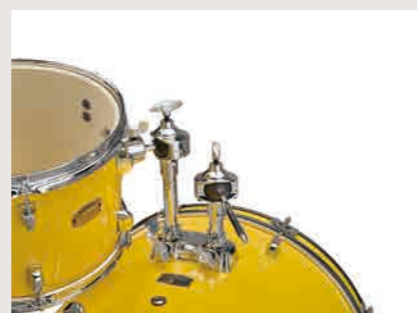

Adding Tom Clamp <CL940B>

Shell Packages

	Bass Drum	Floor Tom	Tom Tom		Snare Drum	Tom Holder
RDP2F5	22" x 16"	16" x 15"	12" x 8"	10" x 7"	14" x 5.5"	CL940LB x 2
RDP0F5	20" x 16"	14" x 13"	12" x 8"	10" x 7"	14" x 5.5"	CL940LB x 2

Specifications

	Bass Drum	Floor Tom	Tom Tom	Snare Drum
Tom Clamp	CL940LB			
Shell	Poplar 6 ply (7.2mm)			
Hoop	Steel Hoop with matching color inlay		Triple flange hoop (Steel 1.5mm)	
Head	Batter: Clear with ring mute, Front: Ebony with ring mute		Batter: Clear, Bottom: Clear	Batter: Coated, Bottom: Snare Side
Lug	Separate lug			

Snare Drums



Wood Snare Drums

Live Custom Hybrid Oak



LHS1455 Size 14"×5.5"

Color Finishes

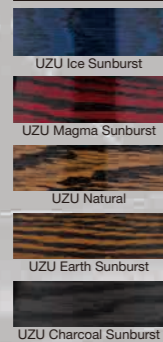

Recording Custom



RBS1455 Size 14"×5.5"



RBS1480 Size 14"×8"

Color Finishes

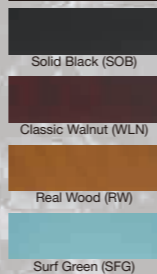

Absolute Hybrid Maple



AMS1460 Size 14"×6"

Color Finishes



Tour Custom



TMS1455 Size 14"×5.5"

Color Finishes

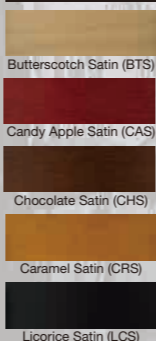

TMS1465 Size 14"×6.5"

Stage Custom



SBS1455 Size 14"×5.5"

Color Finishes



Metal Snare Drums

Recording Custom

Aluminum



RAS1455 Size 14"×5.5"



RAS1465 Size 14"×6.5"

Brass



RRS1455 Size 14"×5.5"



RRS1465 Size 14"×6.5"



RRS1365 Size 13"×6.5"

Stainless



RLS1455 Size 14"×5.5"



RLS1470 Size 14"×7"

Stage Custom



SSS1455 Size 14"×5.5"



SSS1465 Size 14"×6.5"

Snare Specifications

		Dimensions		Shells		Hoop	Lug	Snare bed	Strainers		Head		Snare wire	Bearing Edge		
		Depth	Diameter	Thickness	Material				Release Side	Butt Side	Top	Bottom				
Wood Snare	Live Custom Hybrid Oak	LHS1455	5.5"	14"	7ply 7.3mm	Oak, Phenolic Sheet Hybrid	2.3mm DynaHoop (dark silver finished)	Absolute Lug (dark silver finished)	2.7mm	Q type (dark silver finished)	DC3 type (dark silver finished)	Remo US Coated Ambassador	Remo US Snare Ambassador	25 Strands/High Carbon Steel	45 degrees /R1.5	
	Recording Custom	RBS1455	5.5"	14"	6ply 6.0mm	Birch	1.6mm Triple Flange Hoop	One-piece Lug	2.7mm	Q type	DC3 type	Remo US Coated Ambassador	Remo US Snare Ambassador	25 Strands/High Carbon Steel	30 degrees /R1.5	
		RBS1480	8"	14"	6ply 6.0mm	Birch	1.6mm Triple Flange Hoop	One-piece Lug	2.7mm	Q type	DC3 type	Remo US Coated Ambassador	Remo US Snare Ambassador	25 Strands/High Carbon Steel	30 degrees /R1.5	
Wood Snare	Absolute Hybrid Maple	AMS1460	6"	14"	7ply 6.2mm	Maple, Wenge Hybrid	3.0mm Aluminum Die-cast	Hook Lug	2.7mm	Q type	DC3 type	Remo US Coated Ambassador	Remo US Snare Ambassador	25 Strands/High Carbon Steel	45 degrees /R1.5	
	Tour Custom	TMS1455	5.5"	14"	6ply 5.6mm	Maple	2.3mm Inverse Dyna Hoop	Absolute Lug	2.7mm	P type	P type	Remo US Coated Ambassador	Remo US Snare Ambassador	20 Strands/High Carbon Steel	45 degrees /R1.5	
		TMS1465	6.5"	14"	6ply 5.6mm	Maple	2.3mm Inverse Dyna Hoop	Absolute Lug	2.7mm	P type	P type	Remo US Coated Ambassador	Remo US Snare Ambassador	25 Strands/High Carbon Steel	45 degrees /R1.5	
Wood Snare	Stage Custom	SBS1455	5.5"	14"	6ply 7.2mm	Birch	1.5mm Triple Flange Hoop	One-piece Lug	1.8mm	B type	DC type	Remo UT Coated Ambassador	Remo UT Snare Ambassador	20 Strands/High Carbon Steel	45 degrees /R1.5	
	Metal Snare	Recording Custom	RAS1455	5.5"	14"	1.2mm	Aluminum	3.0mm Aluminum Die-cast	One-piece Lug	2.4mm	Q type	DC3 type	Remo US Coated Ambassador	Remo US Snare Ambassador	20 Strands/High Carbon Steel (SG type 10 strands included)	45 degrees
			RAS1465	6.5"	14"	1.2mm	Aluminum	3.0mm Aluminum Die-cast	One-piece Lug	2.4mm	Q type	DC3 type	Remo US Coated Ambassador	Remo US Snare Ambassador	25 Strands/High Carbon Steel	45 degrees
RRS1455			5.5"	14"	1.2mm	Brass	2.3mm Dyna Hoop	One-piece Lug	2.4mm	Q type	DC3 type	Remo US Coated Ambassador	Remo US Snare Ambassador	20 Strands/High Carbon Steel (SG type 10 strands included)	45 degrees	
Stage Custom		RRS1465	6.5"	14"	1.2mm	Brass	2.3mm Dyna Hoop	One-piece Lug	2.4mm	Q type	DC3 type	Remo US Coated Ambassador	Remo US Snare Ambassador	25 Strands/High Carbon Steel	45 degrees	
		RRS1365	6.5"	13"	1.2mm	Brass	2.3mm Dyna Hoop	One-piece Lug	2.4mm	Q type	DC3 type	Remo US Coated Ambassador	Remo US Snare Ambassador	20 Strands/High Carbon Steel	45 degrees	
		RLS1455	5.5"	14"	1.2mm	Stainless steel	2.3mm Dyna Hoop	One-piece Lug	2.4mm	Q type	DC3 type	Remo US Coated Ambassador	Remo US Snare Ambassador	20 Strands/High Carbon Steel (SG type 10 strands included)	45 degrees	
Stage Custom	RLS1470	7"	14"	1.2mm	Stainless steel	2.3mm Dyna Hoop	One-piece Lug	2.4mm	Q type	DC3 type	Remo US Coated Ambassador	Remo US Snare Ambassador	25 Strands/High Carbon Steel	45 degrees		
	SSS1455	5.5"	14"	1.0mm	Steel	1.5mm Triple Flange Hoop	One-piece Lug	1.8mm	B type	DC Type	Remo UT Coated Ambassador	Remo UT Snare Ambassador	20 Strands/High Carbon Steel	45 degrees		
	SSS1465	6.5"	14"	1.0mm	Steel	1.5mm Triple Flange Hoop	One-piece Lug	1.8mm	B type	DC Type	Remo UT Coated Ambassador	Remo UT Snare Ambassador	20 Strands/High Carbon Steel	45 degrees		

Technology

Innovations that add up to make the Yamaha difference

Drums are deceptively simple instruments: shells, hoops, heads, and hardware to hold it all in place. The reality is much deeper and more complex. The superior sound and playability of Yamaha drums, as well as flexible positioning and solid reliability, depend on a surprising array of technical innovations. All of these innovations, no matter how much they individually contribute, are indispensable to the sublime totality that is Yamaha Drums.



“Air Seal System” Technology

At Yamaha, the process of manufacturing drum shells begins with the selection of the materials. Select woods are cut into sheets with precision cut diagonal ends. The plies are fit into a form and hammered into place by a highly skilled craftsman. The angled ends allow the craftsman to finely adjust the ply length, thus maintaining proper tension. Ply joints are staggered by 120-degrees and hammered into place in the same manner. An air bag placed inside of the shell and inflated at high-pressure puts even pressure on the shell's inner surface creating a perfectly round shell with uniform thickness and excellent durability. This is the Air Seal System, a process that has been in use at Yamaha for over 40 years.

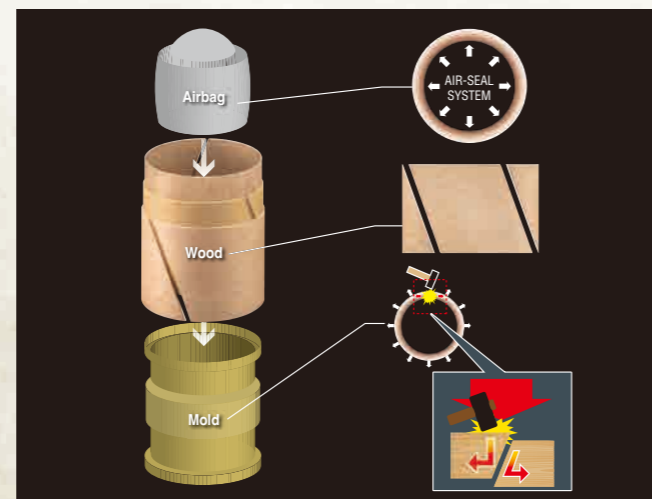

Hybrid Shell Construction for PHX Series (U.S.PAT. 8022281)

With the wealth of knowledge that Yamaha has amassed through the decades as the preeminent maker of musical instruments, Yamaha's wood specialists have discovered new materials that provide optimal drum performance.

Jatoba, a Brazilian wood and the hardest material in the PHX hybrid shell, is positioned as the core ply and center note of the drum. It is surrounded on either side by layers of kapur, a Malaysian hard wood. North American Maple, which had long been considered a classic, high-quality drum shell material because of its hardness and viscosity, is actually the softest wood in the shell construction; maple is the outer and inner plies of the shell.

This is the process used to complete the hybrid shell, in which the stiffness of the shell shifts from the center toward the outside: the woods are hardest at the center and get softer toward the outer surfaces in either direction. This results in an "excitation structure" that maximizes the shell's performance. The excitation structure increases the head's vibration to its full extent, achieving a sound unlike anything you've heard before.

It produces an effect in sound waves similar to rippling waves caused by a pebble dropped in water.

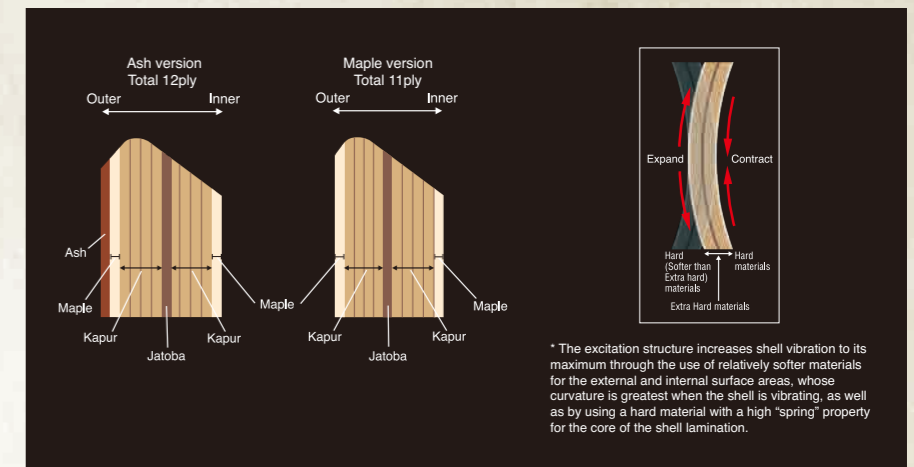

YESS—Yamaha Enhanced Sustain System

Yamaha has spared no effort in designing a mounting system that brings out the natural resonance of tom shells without compromise. Brackets and shells are connected using the smallest possible contact area, and the connection is made at the shell's nodal points so that resonance damping is minimal. These are the basic concepts that were behind the development of the YESS mounting system. Where it was previously necessary to adjust the rod length to achieve optimum resonance, or in some cases to subdue an excessively resonant shell, YESS makes it easy to achieve ideal resonant characteristics. YESS was further refined for the PHX series drums, resulting in the YESSII system in which no metal is used at the contact points: special rubber components attach the shell to the mounting plate with bolts so that vibration from the shell to the tom mount and stand is reduced to a bare minimum. The mounting plate itself is made of maple, further contributing to rich shell resonance. An evolutionary step up from our YESS II tom mount, the YESS III reduces acoustic dampening even further. Allowing the shell to vibrate more freely, the YESS III mount brings out more of the shell's natural sustain and volume.

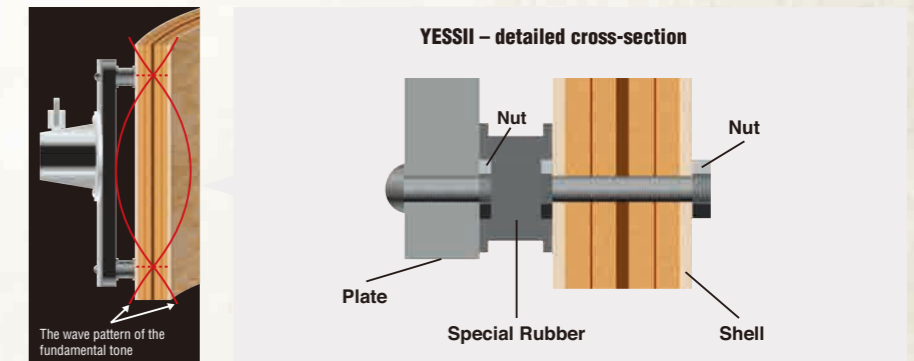

Lugs

Yamaha lug casings hold the tension rods firmly in place, and afford precise tuning in the smallest increments without slippage. From our innovative hook lugs that allow lightning quick head changes to the fixed small lugs used on the Live Custom series, all are low-mass designs that attach to the shell via a single bolt to ensure optimum shell resonance. Our legendary one-pieces high-tension lugs are precision machined to allow high-tension tuning while reinforcing the shells at the same time.

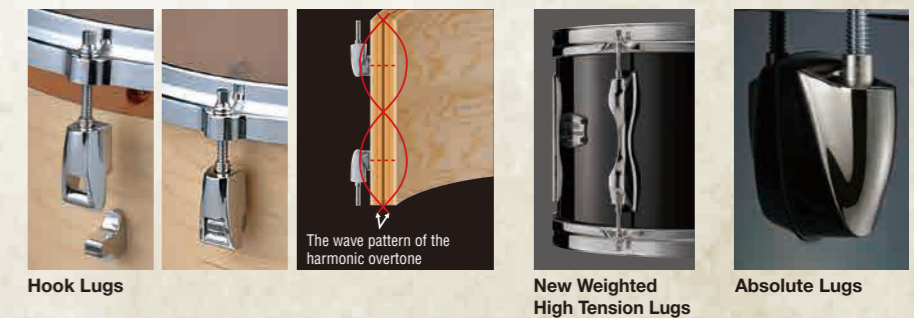

Bearing Edge

Yamaha employs a variety of bearing edge profiles in different drum series, according to the type of sound that is to be achieved. The cut angle and radius of the edge are precisely formed in numerous combinations that result in tonal characteristics matching a wide range of musical genres. Sharper angles and radii result in crisper tonality with fast attack, while more gentle angles and radii lead to fuller, fatter tone. Bearing edges are critical in achieving the desired sound, and in some cases separate edge profiles are used for the top and bottom heads on a single shell.

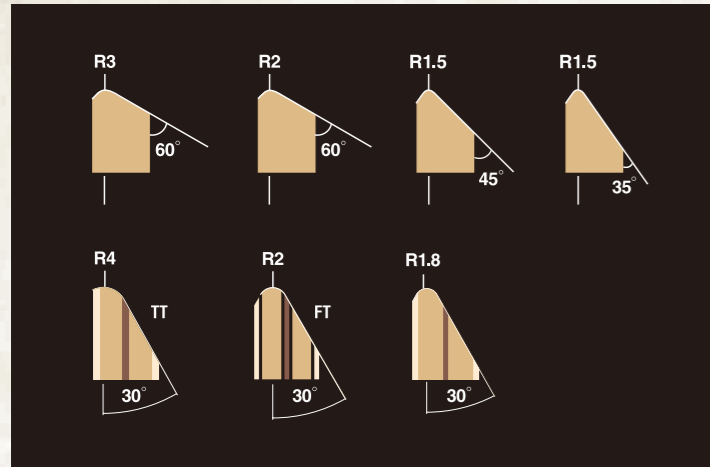

Bass Drum Legs

Holding these powerful drums in place are our Absolute series bass drum legs. Large pipes are Yamaha engineered for greater durability and stability. Spurs slide in and out with a handy knob that also shows spur position at a glance, and a standard drum key locks spurs and height adjustment in place.



Vintage Coating

In order to best demonstrate the characteristics of the shell materials, special synthetic resin coating materials are carefully applied by hand. This thin but hard coating provides durability and stubborn resistance to changes in temperature and humidity. At the same time, it has a minimal effect on shell vibration, so the each drum produces all the power and nuance you put into it. Another special feature of your Vintage Coated* Yamaha drums is that they'll gradually become richer and deeper in color over time.

*The color change is a characteristic of this special coating material.

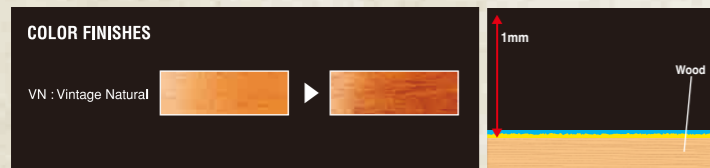

Textured Coating

Textured finishes are Yamaha's newest finishing innovation, developed specifically for the flagship PHX series drums. By applying a coating that is less than half the thickness of standard finishes and hugs the minute natural contours of the wood surface, the natural beauty of the wood grain is emphasized while shell damping is reduced to an absolute minimum.

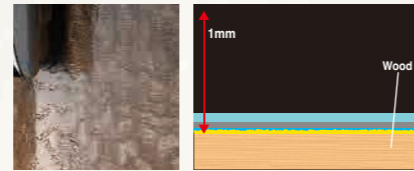

Gloss and Matte Finishes

High quality finishes are defining characteristics of Yamaha drums. As a general musical instrument manufacturer we have a broad base of finishing technology from which to draw, including piano finishing that demands extremely high levels of know-how and experience. The creation of beautiful glossy finishes requires that every step of the process – consistent application of coatings by wiping and spraying combined with meticulous sanding and buffing – be carried out by hand with care and competence that can only be acquired through years of practice. Matte finishes are no easier to produce, requiring multiple levels of accomplished craftsmanship.

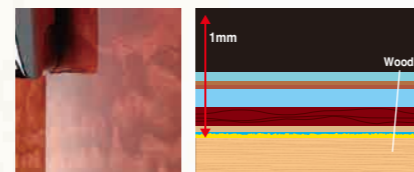

Sparkle & Decorative Finishes

Sparkle and other types of decorative finishes are commonly produced by applying a thin decorative outer wrap of PVC (Polyvinyl Chloride) to the drum shell. Yamaha believes that such "wrap finishes" result in excessive shell damping and compromised resonance, and insists on using coatings to achieve the same visual effect while maintaining optimum tone wherever possible. Yamaha sparkle finishes use generous quantities of aluminum flakes to deliver arresting visual impact in a range of attractive colors.

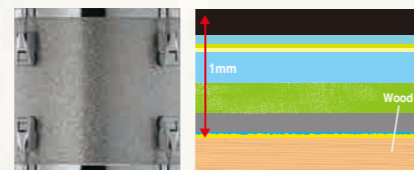

UZUKURI Finishes

The traditional Japanese technique known as "UZUKURI" has been modified for use on drum shells. In this procedure, the soft areas in the wood grain are sanded and then the whole shell is coated with a thin layer of black paint. The entire surface of the shell is then sanded again before the final coating is applied, in a process that emphasizes the natural beauty of the Oak grain.



Maple

Model

- PHX
- Absolute Hybrid Maple
- Tour Custom



Commentary

Sometimes called "hard maple," this wood is highly regarded by drummers in all musical genres around the world for its wide tonal range and outstanding balance.

Birch

Model

- Recording Custom
- Stage Custom
- Junior Kit



Commentary

Birch is a lustrous wood with a tight, dense grain. Birch has played a major role in defining the Yamaha drum sound.

Kapur

Model

- PHX



Commentary

Yamaha wood specialists are so impressed by the potential of this material that they have deemed it ideal for use in drums. Kapur is very hard, while at the same time offering excellent sound transmission characteristics.

Oak

Model

- Live Custom Hybrid Oak



Commentary

Although difficult to work, Oak was first successfully used in drum shells by Yamaha. The result was a powerful sound, visually enhanced by the beautiful grain of the wood.

Ash

Model

- PHX



Commentary

Yamaha uses Ash for the outermost layer of high-end drum shells, emphasizing its exotic visual appeal. The outermost layers of some PHX series drums are gorgeous Burled Ash.

Jatoba

Model

- PHX



Commentary

The extreme hardness of this wood makes it ideal for use as the core material in top-of-the-line PHX series shells, where it contributes to the well-centered sound of these superb instruments.

Wenge

Model

- Absolute Hybrid Maple



Commentary

Very hard and heavy wood native to Africa. This is ideal for use as the core material in Hybrid shells.

Engineered for Your Sole



Double Chain Drive
FP9C, DFP9C, DFP9CL



This durable, reliable double chain drive boasts fluid movement. The cam at the bottom of the chain can be slid into three positions, allowing the drummer to fine tune the pedal's action to match their preferred performance. It can also be used as a belt drive by replacing the belt that comes included with the pedal.

Direct Drive
FP9D, DPF9D



The direct drive creates a direct link between the footboard and the beater, conveying the movement of the drummer's foot to the beater instantaneously. The link can be slid into three positions, allowing the drummer to fine tune the pedal's action to match their preferred performance.



Axle Stabilizing Bearing Chamber (U.S.PAT. 10529306)

The frame and bearing cover (blue parts) are independently smoothed and precisely fabricated before assembly, allowing them to be aligned with the central axis of the shaft and ball bearings to unleash a smooth rotation.



Low Profile Stabilizing Hinge (U.S.PAT. 10529306)

The hinge base and cover (blue parts) are independently smoothed and precisely fabricated before assembly, allowing smooth foot board performance.



Easy Access Auto Lock Spring Adjustment (U.S.PAT. 10360881)

Moving the spring adjustment knob upward greatly simplifies the traditionally troublesome tension adjustment process. The knob is locked at a 90-degree angle that prevents it from coming loose on its own.

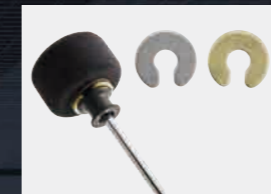

Weight Adjustable Beater (U.S.PAT. 9685146)

Attaching weights to the beater allows drummers to attain their preferred sound and feel. Aluminum (3 g) and brass (9 g) weights are both available and can be attached and removed easily.



Independent Beater/ Footboard Angle Adjustment

The beater angle and footboard angle can be independently and freely adjusted. The inclusion of an angle checker allows drummers to easily recreate their preferred settings.



Ball Bearing Drive Connection (PAT.PEND)

The tip of the foot board comes equipped with ball bearings, allowing even smoother performance.



Anti-Skid Heel Spikes (U.S. PAT. 9691367)

The heel of the pedal comes equipped with spikes that prevent slipping when playing and provide improved stability.

Single Foot Pedal
FP9C



Double Foot Pedal
DFP9C

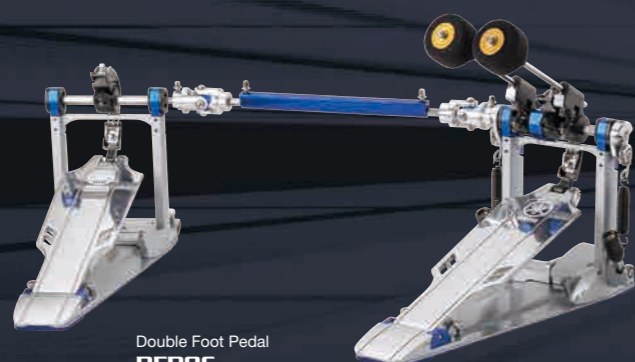

Double Foot Pedal
DFP9CL



Single Foot Pedal
FP9D



Double Foot Pedal
DFP9D



All Bearing Universal Joint

Newly designed universal joints add ball bearings to all axes. The seamlessly smooth rotation dramatically improves the action and operability of the slave pedal.

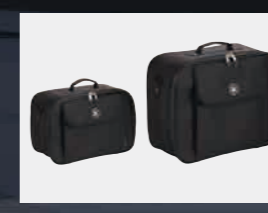

Carrying Case

The FP9 Series comes with its own semi-hard carrying case.



Secondary Pedal Anchor

The slave pedal side also comes equipped with spikes that prevent slipping when playing and ensure stable performance.

Quick Adjusting Cam / Link (PAT.PEND)

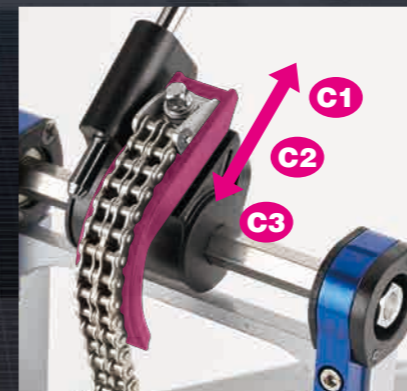

The chain drive gains tension gradually throughout the stroke as the pedal is depressed. Switching the cam from C1 to C3 reduces the initial tension.

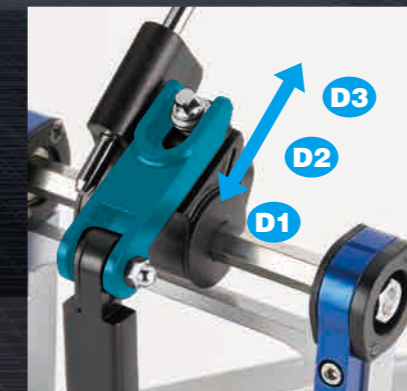

The direct drive gains tension after the tension from the first step recedes. After initially dropping, the tension of the direct drive increases steadily throughout the stroke. Switching the cam from D1 to D3 increases the initial tension.

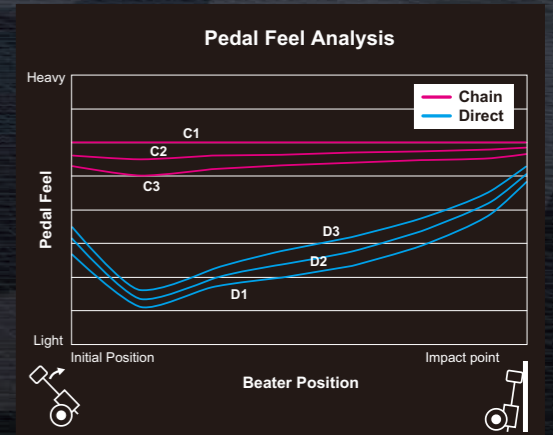

Yamaha Drum Foot Pedal

PLAYABILITY Foot pedals are designed with a wider toe section (a) that offers subtler foot control compared to previous designs. The heel section (b) has been narrowed to maintain the perfect weight balance of prior models and improved performance.

CONVENIENCE The two-way beater offers two ways to play. Instead of simply attaching plastic to the felt, the plastic is wrapped around a large mass of felt delivering greater playability with the felt side.

PLAYABILITY Putting some distance between the beater shaft and the rocker shaft gives Yamaha pedals their unique feel.

SIMPLICITY A teardrop shaped shaft hole holds the shaft in place more securely while eliminating worries about slippage during performance.

DURABILITY Adding a sub-frame just below the rocker shaft, which is subject to the brunt of the load placed on the foot pedal, provides greater durability and stability that withstands intense pedal work.

PLAYABILITY A low resistance, snag-free surface allows finer foot positioning for more delicate footwork.

Labels: Soft, Reversible, Hard, Prior footboard design, Single Foot Pedal FP9500C, Shoe Sole, Pedal Surface, Sub Frame.

Specification List	Direct Drive		Double Chain Drive			Belt Drive	Single Chain Drive
	FP9500D	DFP9500D	(Convertible to the Belt Drive)			FP8500C	FP8500B
			FP9500C	DFP9500C	DFP9500CL (L Type)		
Yamaha Base Plate	•	•	•	•	•	(Linked with connecting rods)	(Linked with connecting rods)
Semi-Hard Case	•	•	•	•	•	•	•
Yamaha's Frame Design	•	•	•	•	•	•	•
BD Hoop Clamp System	•	•	•	•	•	•	•
Foot Board Angle Adjustment	•	•	•	•	•	•	•
Patternless Foot Board	•	•	•	•	•	•	•
Tear Drop Beater Shaft Rocker	•	•	•	•	•	•	•
Beater Angle Adjustment	•	•	•	•	•	•	•
Spring Roller with Bearings	•	•	•	•	•	•	•
Spring Adjust Lock System	•	•	•	•	•	•	•
Long Foot Board	-	-	-	-	•	•	•
2way Beater	•	•	•	•	•	•	•

Option

4 DRIVE SYSTEM TYPES

Four Drive Types Offer Four Different Feels

Direct Drive	Double Chain Drive	Single Chain Drive	Belt Drive
9500D	9500C, 8500C	7210A	8500B
A die-cast aluminum link provides a direct connection between the pedal and beater that transmits pedal control directly to the beater. This high performance drive delivers an overwhelming sense of speed. (FP9500D, DFP9500D)	The double chain drive offers reliable and durable operation with uniform action. The FP9500C/8500C and DFP9500C/9500CL come with a belt letting you switch to a belt drive system if preferred.	The single chain drive provides uniform action with a natural feel.	The belt drive has supple touch and feel that isn't found in chain drive systems.

Yamaha System Hardware Analysis

- Spring Roller with Built-in Bearings**: Precision bearings deliver smooth, natural pedal action. (Excluding FP7210A)
- Beater Angle Adjustment**: Loosening the adjustment screw lets you freely adjust the beater angle along with the footboard angle. (All models)
- Spring Tension Adjustment Lock System**: One hand spring tension adjustment is easy. A lock bolt secures the setting to prevent loosening during play. (Excluding FP7210A)
- Smooth Moving Universal Joint**: A universal joint on the rocker shaft provides angular flexibility for smoother movement. (All models with double foot pedals).
- Footboard Angle Adjustment**: The pedal angle can be set freely to any angle without affecting beater angle. This lets you set the pedal angle you want when the pedal is not pressed. A tuning key is used to make the adjustment, which also lets you align pedal height with your sub, and hi-hat pedals. (FP/DFP9500 Series)
- Compact and Convenient Semi-Hard Case**: The 9500 Series pedals come with a specially designed semi hard case. This case provides protection from damage even when storing the pedals in the trunk case along with the stands that are missing their rubber feet. (FP9500 series, DFP9500 series)

Yamaha Drum Hi-Hat Stand

CONVENIENCE

The hi-hat stand incorporates a self-locking click angle adjuster that makes adjustments quick and easy. The lock engages automatically when the adjuster is released to prevent loosening and eliminate worries.



CONVENIENCE

Adjust spring tension from the comfort of your drum throne. The large dial is conveniently located, easy to rotate, and includes a lock mechanism to prevent loosening.

Hi-Hat Stand HS1200T

PLAYABILITY

Legs are designed to open at 110°. By incorporating a double leg design on both sides, the stand offers greater resistance to front and back movement letting you focus more on drumming.



PLAYABILITY

Mixing leg types, a double leg at center with single legs on the sides, provides greater stability while offering more space for your foot and multiple pedals.

PLAYABILITY

Yamaha's original Toggle Link System delivers a stroke that feels light for the first part but gets increasingly heavier and closer to normal as the stroke continues, making light and nimble footwork possible. (HS1200T only)

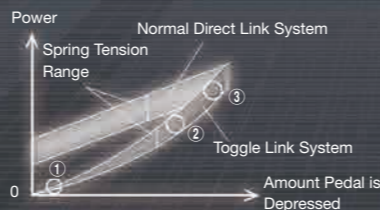

SIMPLICITY

Knock-type spikes that extend with a single touch, combined with large rubber feet keep the stand stable and secure.

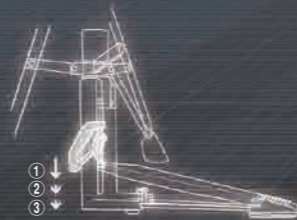

Specification List

Model No.	HS1200T	HS1200D	HS1200	HS850	HS740A	HS650A
Available Height Range	74 ~ 105cm	74 ~ 105cm	74 ~ 105cm	70 ~ 92cm	70 ~ 90cm	70 ~ 90cm
Locking Hi-hat Clutch	●	●	●	—	—	—
Cymbal Support	Hard Rubber / Felt	Hard Rubber / Felt	Hard Rubber	Felt	Felt	Felt
Cymbal Angle Adjustment	● (w/Fixing Nut)	● (w/Fixing Nut)	● (w/Fixing Nut)	●	●	●
Rotating Leg Design	—	—	—	●	●	—
Spring Tension Adjustment	● (with Indicator)	● (with Indicator)	● (with Indicator)	● (11 Increments)	● (11 Increments)	—
Foot Board Angle Adjustment	●	●	●	—	—	—
Toggle Link System	●	—	—	—	—	—
Big Rubber Feet	● (with Spike)	● (with Spike)	● (with Spike)	●	●	(Normal)
Leg Design	2 Double Braced Legs	2 Double Braced Legs	3 Double/Single Braced Legs (Front side legs angle open 150 degree)	3 Double Braced Legs (Front side legs angle open 150 degree)	3 Single Braced Legs (Front side legs angle open 120 degree)	3 Single Braced Legs (Front side legs angle open 120 degree)
Length of included Rod	Long & Regular Rod	Long & Regular Rod	Long & Regular Rod	Regular Rod	Regular Rod	Regular Rod

Yamaha System Hardware Analysis



Long and Regular Rods

Hi-hat cymbal height
With long rod: 739.5mm-1052mm
With Regular rod: 739.5mm-902mm
Two rods, one long one supplied to accommodate lower plating positions.



Footboard

The wider pedal design provides a greater contact surface for your foot delivering a lighter feel and greater playability. Grip is enhanced in the heel section, and the pattern-less surface provides both moderate gripping and smooth movement. A weight balance on the end delivers great playability. Slim form allows closer setting of the double foot pedal. (HS1200T, 1200D, 1200)



Drum Key Holder

Keep your drum key in the handy holder on the stand's pipe. (HS1200T, 1200D, 1200)



Footboard Angle Adjustment

Pedal angle, when not depressed, can be set freely. This lets you align pedal height with other pedals such as in a double foot pedal setup. Rubber coated tie rods help to prevent pedal hopping. (HS1200T, 1200D, 1200)

Option

Long & Regular Rods
PERS/PERL



Locking Hi-hat Clutch
LC930A



Hi-hat Clutch
LC810A



Closed Hi-hat Holder
CHH930

Position a hi-hat in your setup anywhere you like. Spring tension is adjustable.



Yamaha Drum Cymbal Stand

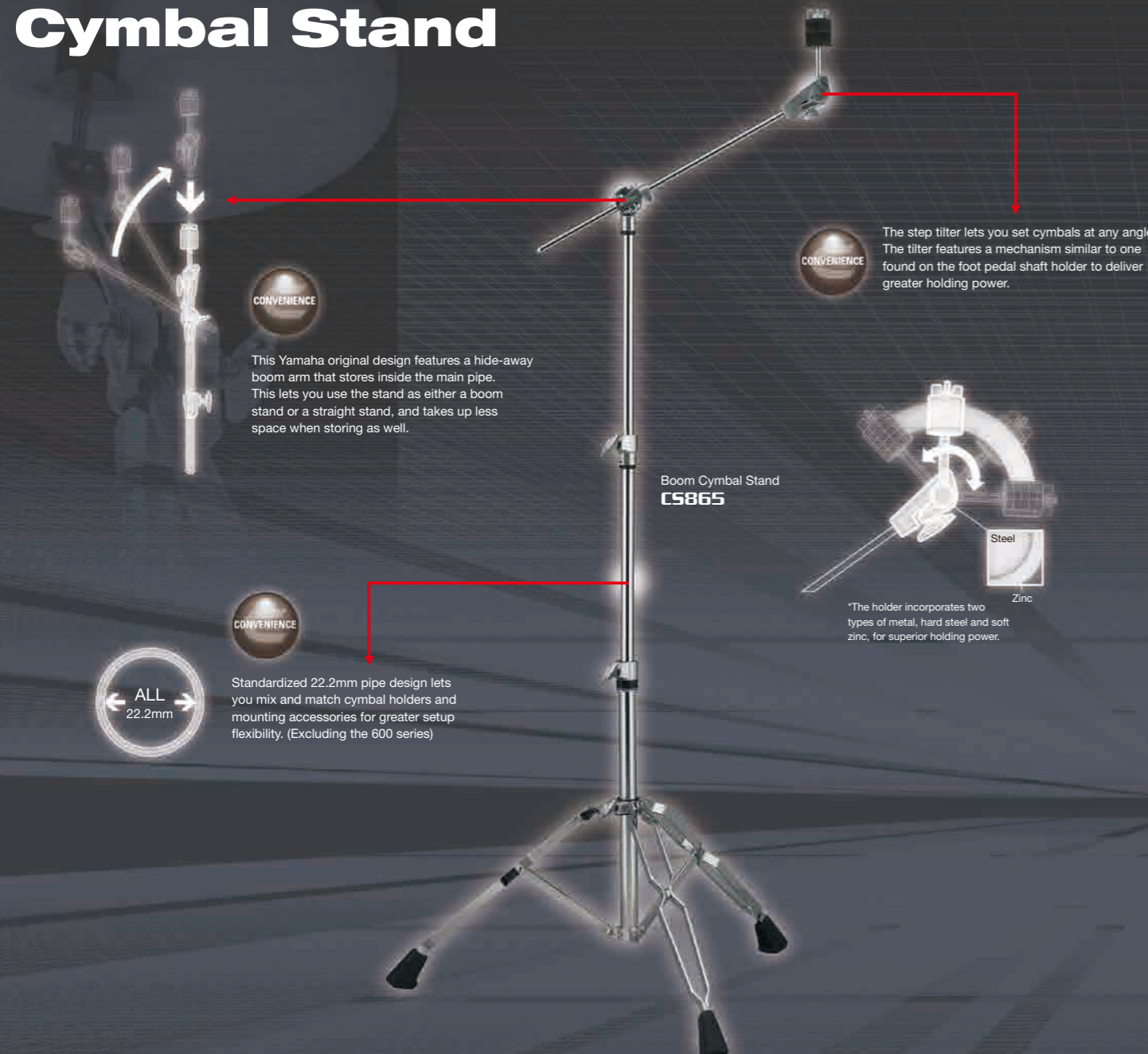

CONVENIENCE

This Yamaha original design features a hide-away boom arm that stores inside the main pipe. This lets you use the stand as either a boom stand or a straight stand, and takes up less space when storing as well.

CONVENIENCE

The step tilter lets you set cymbals at any angle. The tilter features a mechanism similar to one found on the foot pedal shaft holder to deliver greater holding power.

CONVENIENCE

ALL 22.2mm

Standardized 22.2mm pipe design lets you mix and match cymbal holders and mounting accessories for greater setup flexibility. (Excluding the 600 series)

*The holder incorporates two types of metal, hard steel and soft zinc, for superior holding power.



Boom Cymbal Stand CS965 Boom Cymbal Stand CS755 Boom Cymbal Stand CS665A Boom Cymbal Stand CS655A Straight Cymbal Stand CS850 Straight Cymbal Stand CS750 Straight Cymbal Stand CS660A Straight Cymbal Stand CS650A

Specification List

Model No.	CS965	CS865	CS755	CS665A	CS655A	CS850	CS750	CS660A	CS650A
Available Height Range	91 ~ 172cm	94 ~ 175cm	91 ~ 172cm	80 ~ 163cm	79 ~ 162cm	73 ~ 154cm	73 ~ 154cm	63 ~ 140cm	62 ~ 145cm
Offset Tilter	-	-	-	●	●	-	-	●	●
Center Tilter	-	-	●	-	-	-	●	-	-
Step Free Tilter	●	●	-	-	-	●	-	-	-
Big Rubber Feet	●	●	●	-	-	●	●	-	-
Leg Design	Heavy Double Braced Legs	Double Braced Legs	Single Braced Legs	Double Braced Legs	Single Braced Legsss	Double Braced Legs	Single Braced Legs	Double Braced Legs	Single Braced Legs

Option

Cymbal Stand Boom Weight **CSBW**



Cymbal Stand Attachment **CSAT940**

The CSAT940 can be used for two stage cymbal arrangements or a closed hi-hat arrangement.



Cymbal Stand Attachment **CSAT924A**

The CSAT924A connects to the pipes of stands and holders allowing a wide variety of set-ups and positions to be easily achieved.



Cymbal Stand Attachment **CSAT942**

The CSAT942 connects to the tilter and offers fine angle adjustment.

Yamaha System Hardware Analysis



Step Free Tilter

Step free angle adjustment lets you set the cymbal at any position you like. Supporting the cymbal's weight in the center of the pipe provides a more stable setting. (CS800 Series)



Center Tilter

The Center Tilter, long popular among knowledgeable players, has been revived in the CS700/CH700 Series, CSAT942/940 and CWH940 series. By supporting the weight of the cymbal at the center, greater stability is achieved.

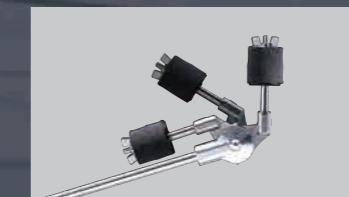

Offset Tilter

The offset tilter stores parallel to the pipe making transport easy and preventing damage. This tilter is used in the CS600 series, which is noted for its light, compact design.



Placing Type BoomTilter Mechanism

Retaining Yamaha's traditional gear mechanism, we now introduce the "clipping" method for securing the boom arm. Through this specification, the main unit of the boom arm becomes more resistant to scratches. It ensures extra peace of mind, even during complex setup adjustments. It begins with the CS865, 755, CH755, 750.

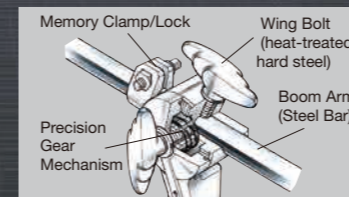

Small Wing Nut, Tilter Sleeve & Felt

A polycarbonate tilter sleeve encases just enough of the head bolt to provide optimum securing of the cymbal. Utilization of a wing nut lets you play the cymbal bell without it getting in the way of the stick.

Pressing type Boom Tilter Mechanism

A precision gear mechanism provides precise adjustment of the boom arm's angle. A wing bolt firmly fixes the boom arm in place while a memory clamp/lock offers quick positioning and prevents rotating. (CS665A, 655A)

Unified Diameter Center Pipe

The center tube assembly accommodates the same 22.2mm diameter pipe as found on other stands so you can replace the upper tube assembly with that of another cymbal stand or tom holder. (except CS655A, CS650A)

Boom Cymbal Holder

Yamaha's cymbal holder fits into the main pipe making it easier to pack and transport.

Big Rubber Feet

In addition to wide stance legs, the big rubber feet supply maximum non-slip grip to keep the stand firmly in place.

Tight & Secure

Specially designed by Yamaha, the nylon bushing holds the pipe firmly in place even when lightly tightened. Since the wing bolt is tightened through a steel nut, the durability of the bolt is increased. (All models)

Yamaha Drum Snare Stand



Specification List

Model No.	SS950	SS850	SS740A	SS662
Available Height Range	45 ~ 61cm	45 ~ 63cm	45 ~ 61cm	43 ~ 62cm
Rubber Arms	3 Arms	3 Arms	3 Arms	3 Arms (for 12" Snare Drum)
Adjustable Angle Tilter	●	-	-	-
Big Rubber Feet	● (With Spike)	●	●	-
Leg Design	Double Braced Legs	Double Braced Legs	Single Braced Legs	Single Braced Legs

Yamaha Drum Stool

Large Seat Mount

(480mm x 390mm)



Specification List

Model No.	DS950	DS840	DS750	DS550U
Seat	Large Square Seat Design 480 (W) x 390 (D) mm	Round Seat Design 330mm (Diameter)	Round Seat Design 300mm (Diameter)	Round Seat Design 300mm (Diameter)
Seat Mount	Large AL Die-cast Seat Mount	Large AL Die-cast Seat Mount	AL Die-cast Seat Mount	AL Die-cast Seat Mount
Height Adjustment	Screw Rod (460 ~ 650mm)	Screw Rod (460 ~ 650mm)	Clamp Rod Type (430 ~ 650mm)	Clamp Rod Type (420 ~ 600mm) (no hole, w/memory clamp)
Leg Ass'y	4 Double Braced Wide Stance Legs	3 Double Braced Wide Stance Legs	3 Single Braced Legs	3 Single Braced Legs

Yamaha Drum Tom Holder

Ball Mount & Clamp

The Yamaha original ball mount and clamp system offers unparalleled flexibility and ease of positioning. A generous sized hard synthetic resin ball sits in an attractive chromed housing that permits the tom hex rod to be positioned in almost any imaginable position. The ball joint friction-free operation provides ease of set up, while a large wing bolt provides one touch locking.

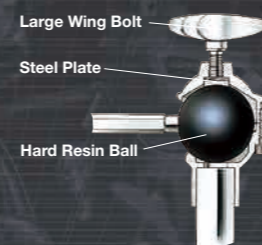

Cap

The cap reduces noise and protects the holder when no tom clamp is inserted.

Pipe Cap

Cap eliminates unnecessary vibrations from the bass drum.



Specification List

Tom Holder			
Model No.	TH945B	TH940B	
Rod	Short (for YESS)	Long	
Tom Holder Base	Triple Mount		Triple Mount
Tom Clamp			
Model No.	CL945LB	CL945B	CL940LB
Rod	Short (for YESS)	Short (for YESS)	Long
Pipe	Long	Short	Long

Yamaha Drum Double Tom Stand

Yamaha's double tom stands have long been recognized for their outstanding freedom in positioning drums. Their simple and durable design offers stable setting while the ball clamp system's ability to rotate 360 lets you position your toms or an additional snare drum exactly where you want.



Specification List

Model No.	WS955A	WS950A	WS865A	WS860A	WS904A
Available Height Range	58 ~ 130cm	58 ~ 130cm	62 ~ 104cm	62 ~ 104cm	45 ~ 76cm
Rod	Short (for YESS)	Long	Short (for YESS)	Long	-
Tom Holder Base	Triple Mount	Triple Mount	Triple Mount	Triple Mount	Triple Mount
Big Rubber Feet	●	●	●	●	●
Leg Design	Heavy Double Braced Legs	Heavy Double Braced Legs	Double Braced Legs	Double Braced Legs	Heavy Double Braced Legs

CROSSTOWN

Advanced Lightweight Hardware

HW3

HW3 Crosstown Advanced Lightweight Hardware Delivers a Compact and Durable Solution for the Gigging Drummer

Strong, light, compact, stable, and natural Cymbal/Snare sound

HW3

- Hardware
 - Cymbal Stands CS3 x 2
 - Hi-Hat Stands HHS3
 - Snare Stands SS3
- Included Accessories
 - Hardware bag with 4 individual inner bags



HHS3
Advanced Lightweight Hi-Hat Stand



CS3
Advanced Lightweight Cymbal Stand



SS3
Advanced Lightweight Snare Stand

Specifications

Model	Advanced Lightweight Hardware Set	Cymbal Stand	Hi-Hat Stand	Snare Stand
	HW3	CS3	HHS3	SS3
	CS3 x 2, SS3, HHS3, Hardware bag			
Weight	7.8 kg (17.2 lbs) * include Hardware bag	1.5 kg (3.3 lbs)	2.2 kg (4.8 lbs)	1.5 kg (3.3 lbs)
Available Height Range	-	61 - 133 cm (24" - 52.3")	62 - 90 cm (24.4" - 35.3")	42 - 58 cm (16.3" - 22.8")
Accessories	Hardware bag, Inner bag x 4	Inner bag	Inner bag	Inner bag



Durable Aluminum channel legs
Non-slip rubber foot



Channel-track aluminum bracing

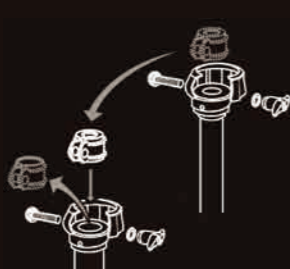

3-tier to 2-tier convertible for more compact and lighter (CS3)



Increased natural and open sound from cymbals and snare drums



Inner bag included for protection

HEXRACK II

Turning Your Imagination Into Form



Innovatively Designed Aluminum Pipe... Stronger, Lighter in Weight

The HEXRACK II utilizes a complex cross section design evolved from the original HEXRACK. The pipes are made from an aluminum alloy. This combination of design and material produces pipes that are significantly lighter in weight while providing greatly improved strength—as much as double that of conventional round pipe.



Basic 2-leg set HXR2L II

Expand With Accessories or What You Already Have

If you want to expand your HEXRACK II system, Yamaha offers a wide selection of individual add on parts that let you customize your system exactly the way you want to. The HEXRACK II is also compatible with 22.2-diameter hardware as well as the original HEXRACK system parts so you can add on to your new system with anything you might already have.

Get A Grip

HEXRACK II clamps get a rock solid grip on the rails with a synthetic sleeve that fits between the clamp and the rail. As the clamp tightens, it compresses the sleeve to establish a solid grip. This gives the clamp a secure, slip-free hold on the rail when tightened, and allows easy adjustment when loosened, making the whole setup process quick, easy, flexible, and solid.

Solid grip



Synthetic Sleeve

COMPATIBILITY

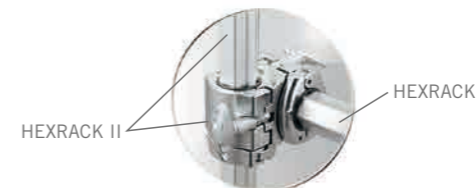

Expansion set HXREX II



HXAC II



HXDB II

DRUM RACK ACCESSORY

CLAMPS	HEX PIPES	ATTACHMENTS
HXOC II	HXCP44 II	HXLC II
HXAC II	HXCP36 II	
HXDB II	HXCP24 II	
HXTC II	T-leg	
HXCC II	HXTL30 II	
	HXTL23 II	



HXCC II



HXTC II



HXOC II



HXLC II

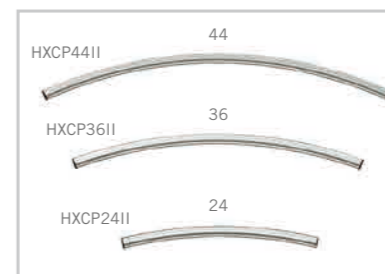

Curved Pipe



T-leg

Great Strength Without The Weight

For as solid as the new HEXRACK II system is, it is amazingly light. Using a special aluminum alloy, the HEXRACK II design team created a six-sided, slotted rail that offers an optimum balance of light weight and strength. These rails are unmatched for rigidity and weight, and resist warping and compression.





Electronic Acoustic Drums

Mic Your Drum in Seconds

Hear your acoustic Drums in the headphones/speaker and you control the volume. From the use of iOS / Android App "Rec'n'Share", you can record with your favorite bands and create great-sounding videos and easily share on social.



Mechanism

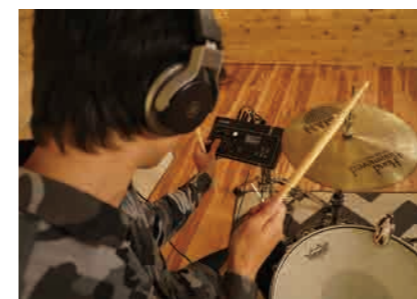
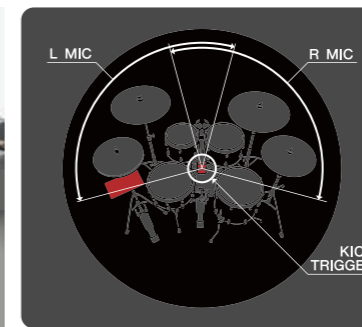

The Sensor Unit

The sensor unit of the EAD10 comprises a specially developed XY stereo microphone sensor and trigger sensors, allowing you to capture a balanced recording of the sound of the entire kit by placing this at the center of the kit itself.

Additionally, the range of sounds that can be created has been greatly expanded by using the trigger sensor to combine bass drum sounds with a PCM sound source.

The EAD10 has achieved both simplicity and quality by combining the technologies that could only be developed by a comprehensive manufacturer well versed in both the characteristics of instruments and microphones.

The Main Unit

The main unit of EAD10 is designed with ease of use in mind.

The left side of the main unit comes equipped with large knobs that can easily be adjusted mid-performance, so that the main control functions can be accessed easily. The buttons and LCD display on the right allow for even more detailed adjustments.

Additionally, a high-performance headphone amplifier was also developed specifically for this unit, and delivers power and performance that cannot be outdone by the dynamic sounds of acoustic drums.

It also comes equipped with many high-quality effects and PCM sound sources used in Yamaha electronic musical instruments. Furthermore, by using the trigger sensing technology from electronic drums, it creates added value for acoustic drums, making them into a completely new musical instrument.

Product

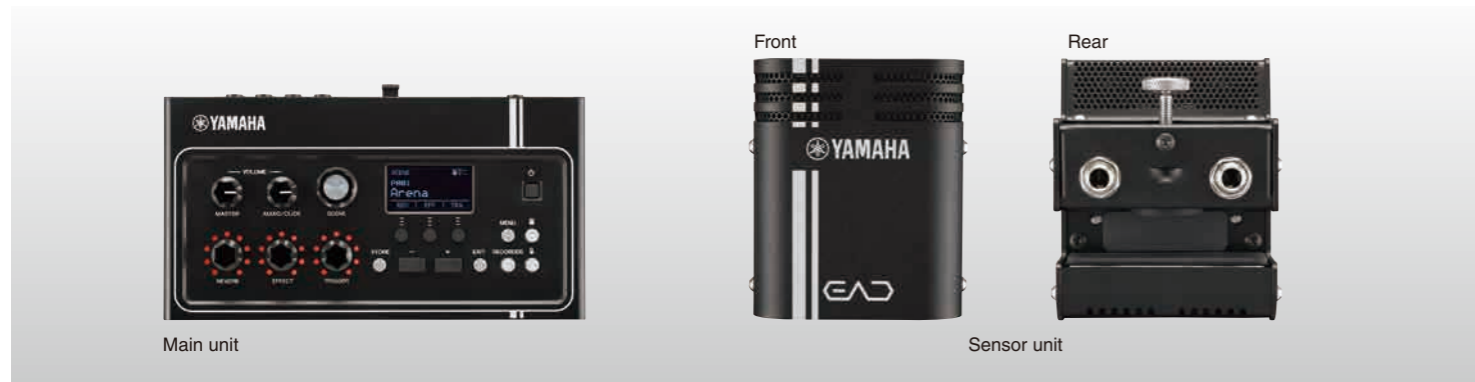

Main unit

Sensor unit

EAD10 Specifications

Size/Weight		Width	260mm (Main Unit), 76mm (Sensor Unit)
Dimensions	Height	63mm (Main Unit), 88mm (Sensor Unit)	
	Depth	138mm (Main Unit), 78mm (Sensor Unit)	
	Weight	Weight	654g (Main Unit), 464g (Sensor Unit)
Tone generator		Preset: 50 User: 200	
Reverb		11	
Effects		Mic: 21, Trigger: 10	
Trigger Sounds	Tone generator	AWM2	
	Maximum polyphony	64	
	Voices	757	
Recorder			
Recording time	Internal memory	Approx. 1 min 30 sec	
	USB flash drive	Approx. 90 min/file	
Recording Format	Record/playback	WAV (44.1 kHz, 16 bit, stereo)	
Audio Files			
Import limit		Up to 100	
Playback sample format		44.1 kHz	
Wave memory		32 MB	
Maximum loadable sample size		1 mono sample: 1.75 MB, 1 stereo sample: 3.5 MB	
Sample format		WAV (16 bit)	

Click-track			
Tempo		30–300 BPM, tap tempo function	
Time signatures		1/4 to 16/4, 1/8 to 16/8, 1/16 to 16/16	
Subdivisions		Accents, quarter notes, eighth notes, sixteenth notes, and eighth-note triplets	
Functions			
Functions		Trigger sensitivity adjustment, USB audio/MIDI, headphone EQ, Metronome, Auto Power off	
Connectors			
Connectors		DC IN (12 V), PHONES (standard stereo phone), AUX IN (stereo mini), OUTPUT L/MONO, R (standard mono phone), USB TO DEVICE, USB TO HOST	
Sensor Unit	For Trigger sensor	A (standard stereo phone)	
	For Mic sensor	B (standard stereo phone)	
	Stereo (L: trigger, R: trigger)	1 KICK/2 (also serves as A), 3 SNARE/4 (standard stereo phone)	
Trigger input	Three-zone (L: trigger, R: rim switch)	5, 6 (standard stereo phone)	
	Foot Pedal	FOOT SW (standard stereo phone)	
Sensor outputs	For Trigger sensor	A (standard phone)	
	For Mic sensor	B (standard stereo phone)	
Sensor Types			
Microphone		High SPL mic × 2	
Trigger		Exclusive for bass drum × 1	
Other			
Included Accessories		Owner's Manual, PA-150 (or an equivalent recommended by Yamaha)*, Module holder, Module holder wing bolts (× 2), Connector cables (1 pair), Cable bands (× 3), Adhesive cushions (× 2)	

Features

Mic your Drum kit in seconds

EAD10 can capture the sounds of an entire drum kit and monitor them at a high quality just by attaching the sensor unit to the bass drum. By simply turning the knob on the main unit, you can control various effects and change the drum sound as you wish. If a speaker is connected to the EAD10 output terminal, it can be used as a simple PA system. You won't have to spend time mic-ing drums during live performance.



Connect with smart device / App

EAD10 can be played with your favorite music on smart devices via AUX cable or USB cable connections. In addition, by using the Android/iOS App "Rec'n'Share", you can practice by adding a metronome to your favorite music, record audio, record video, edit, and upload to SNS, etc.

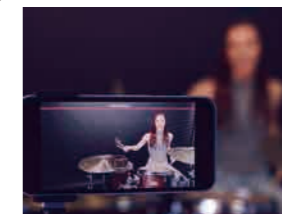

Add Trigger & Pad

EAD10 can connect to a maximum of 6 triggers and pads including the bass drum trigger of the sensor unit. Percussion sounds, electronic sounds, and loops, among other things, can be incorporated to expand the range of expression.



Talkback function

EAD10 features a talkback function. A player's voice can be captured by the microphone sensor of the unit sensor by operating the buttons on the main unit, or by using the pedal. This function can be used in various circumstances, including video creation and web lessons.



Use EAD10 with a mesh drum kit

Combining EAD10 with a low-volume drum kit using mesh heads and low-volume cymbals leads to the birth of an entirely new drum kit. Playing PCM sound with triggers attached to each drum and capturing raw sounds, including those of cymbals from the microphone sensor of the sensor unit, allows the raw sound of the drums themselves to be kept at a low volume while realistic drum sounds are output through the headphones and speakers. Settings that resemble that of a real drum kit lend themselves to the production of a performance that feels more real than ever before.

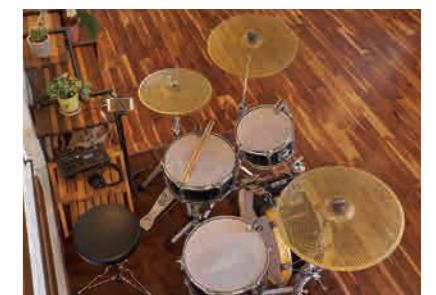

iOS / Android App Rec'n'Share



Price: free
Work with: EAD10/DTX402 series
Stand alone: △
 * Only practice functions usable.
Device: iPhone, iPad, Android devices



* Automatically analyze the tempo of songs selected from the music library of your device and add a click to match. You can also alter the tempo and use functions such as A-B repeat when practicing.
 * After recording sound or video, you can cut unnecessary material from the beginning or end of clips and alter the volume balance of the sound and instruments.
 * Upload your original videos to sites such as Youtube, Facebook, Dropbox, and Instagram easily.

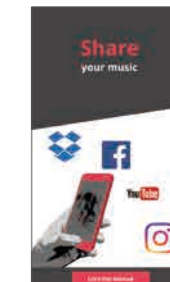

DTX

drums

The One to Beat

The DTX drums series electronic drum sets - Created for all drummers with a passion to be the best that they can be. The realistic feel and rich expressive sound of these instruments will take you to even greater musical heights.



We believe
DTX drums



Akira Jimbo

"There's none of the stress you sometimes get when switching from an acoustic drum to an electronic one - this is truly a groundbreaking product for drummers!"



Teddy Campbell

"The DTX has revolutionized electronic drums. Its real feel and in your face sound quality are the best I've ever experienced."

DTX-PAD

The DTX-PAD Offers The Ideal Feel

After years of designing and manufacturing some of the world's finest drums, Yamaha knows what it means for drums to feel good and play naturally. We designed the DTX-PAD to be the new standard in electronic drum pads, providing drummers with a pad that feels good, offers playability that is as close as possible to acoustic drums, and is exceptionally quiet. Teaming up with the world's top drummers to satisfy their demanding sense of perfection, we focused our knowledge and experience into designing the DTX-PAD. This next generation drum pad allows for true development of acoustic drumming techniques.

Closed Rim Shot



Open Rim Shot



Open Rim Shot



Closed Rim Shot

Pad Controller

Pad pitch and snare tension are adjustable from the pad with a single knob. (XP120SD/T, XP100SD/T)

Rim

A 3-zone design offers the same expressive capabilities as acoustic drums, making closed rim shots, open rim shots, and other playing techniques possible (excluding the XP70).

3-zone pad:
Application number
US14/735641 (patent pend.)



Floating System

Designing the pad with a floating playing surface improves pad sensitivity. This allows it to clearly articulate accents from ff to pp and detailed ghost notes—all essential requirements for drums.

TCS Head (Textured Cellular Silicone Head)

Like a coated head on an acoustic drum, a certain amount of roughness helps to control stick slippage after hitting the head. This provides stick control comparable to that on an acoustic drum.

TCS Head Incorporates A Bubbled Structure

Inside the TCS head are a countless number of tiny bubbles. Controlling the size and density of the bubbles produces a variety of advantages.

Stick Control Close To Acoustic Drums

Stick control on the pad surface has been fine-tuned to a level that is close to what you experience on an acoustic drum. Rebound is natural with just the right amount of bounce to get the stick back into position in time for the next stroke. Snare and tom pads also have a slightly different response so as you move around the set it feels almost as natural as an acoustic kit. (XP120SD/T, XP100SD/T)



Feels Comfortable To Play

Years of research has resulted in a playing surface that offers optimum rebound and stiffness delivering playing comfort that makes it hard to stop playing.

Extremely Quiet

Bubbles in the TCS head act to cushion the stick's blow reducing the amount of "sound" produced when playing.

Reduces Stress On Wrists And Elbows

When the stick hits the pad's surface, the bubbles absorb the shock to significantly reduce stress on wrists and elbows.

GET ON A ROLL

DTX402 series



The moment you play the DTX is the moment you become a drummer. Let it be your inspiration and give instant expression to your impulses and creativity. DTX402 is the culmination of the commitment Yamaha makes as a drum manufacturer with excellent design and sound quality.



SOUND

The sound provided by DTX makes drumming so much fun that you'll never want to stop. The DTX402 sounds combine years of experience creating authentic, top-quality drum sounds with 10 built-in drum kits, including acoustic effects and electronic sounds to help you find the perfect voice. You can easily create your own kits and choose from the various high-quality sounds. Give voice to your musical sensibilities with the expressive range of the DTX.



Apps

The free DTX402 Touch app allows any user to easily customize drum kits and take advantage of the training functions. The new Challenge mode gamifies learning to engage and encourage practice and help you quickly develop drumming skills with various genres of music. The DTX402 series also works with the Rec'n'Share app so you can practice and perform with your favorite music and quickly share on social.



SEND USB AUDIO/MIDI TO YOUR DEVICE/COMPUTER

Connect the module to your smart device/computer via USB, and create audio data from sounds produced in the DTX. Connecting the module to your smart device and linking it to your camera app allows you to easily create videos with sounds produced on the DTX402. You can also connect it to your computer and link it with a DAW (digital audio workstation) for music production.



DTX402 MODULE SPECIFICATIONS

	Voices	Drum and percussion: 287, Keyboard: 128
	Drum kits	10 (all of which may be edited and overwritten)
Tone generator	Songs	10
	Reverb	9 types
	Tempo	30 to 300 BPM (Tap Tempo and Voice Guidance functions)
Metronome	Beat	1/4 to 9/4
	Jacks and terminals	SNARE (mini stereo audio), TOM1 (mini mono audio), TOM2 (mini mono audio), TOM3 (mini mono audio), RIDE (mini mono audio), CRASH (mini stereo audio), HI-HAT (mini mono audio), HI-HAT CTL (mini stereo audio), KICK/PAD (mini stereo audio), USB TO HOST (type B), AUX IN (mini stereo audio), PHONES/OUTPUT (standard stereo audio), DC IN
Other	Dimensions and weight	269 (W) x 147 (D) x 39 (H) mm, 0.5 kg 10-9/16" (W) x 5-13/16" (D) x 1-9/16" (H), 1 lb 2 oz
	Accessories	Power Adaptor (PA-130 or an equivalent recommended by Yamaha), Owner's Manual

TRAINING

The DTX comes with 10 built-in training functions that are only possible with an electronic drum and you can access through the module and with the app. The module talks to you to encourage you as your trainer, partner! These include the Song Part Gate function, which trains you up gradually over time, the Rhythm Gate Function, which fosters a precise sense of rhythm – fundamental for drumming, and the Fast Blast Function, which measures the speed of your strokes. There is also a scoring function so you can assess your skills objectively. Take advantage of this complete range of support functions to improve your power of expression as a drummer.



DURABLE/QUIET/EXPRESSIVE

These highly durable pads and racks have passed Yamaha's rigorous durability tests and will save you the effort, time, and cost that would normally go into the maintenance or replacement of parts. The firm response of the heads is perfect for practice and allows you to clearly feel the beat you're playing, while the snare and tom pads incorporate Yamaha's unique floating system to deliver a quiet yet pleasant response. Professional engineers weren't the only ones involved in the development of the DTX402 sounds—the performances of multiple drummers were used to fine tune them and make them as naturally expressive as possible, giving them a natural response and expression that allows a smooth transition to acoustic drums.



*Wiring not shown.

DTX452K

- TP70S 3-zone snare pad that allows you to play directly on the snare head or play open or closed rimshots.
- KP65 kick pad and a genuine Yamaha bass drum pedal FP6110A provide smooth action and real feel.
- HH65 hi-hat controller for expressive hi-hat performance.

DTX452K SPECIFICATIONS

Module	DTX402
Pad Snare	TP70S (7.5 inch) 3-zone Pad
Tom1, 2	7.5 inch pad
Floor Tom	7.5 inch pad
Bass Drum	KP65
Bass Drum Pedal	FP6110A
Hi-Hat	10 inch pad
Hi-Hat Controller	HH65
Crash Cymbal	10 inch pad (Choke Function)
Ride Cymbal	10 inch pad

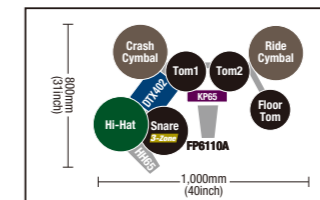

*Wiring not shown.

DTX432K

- Newly developed drum pads incorporating Yamaha's unique floating system.
- KP65 kick pad and a genuine Yamaha bass drum pedal FP6110A provide smooth action and real feel.
- HH65 hi-hat controller for expressive hi-hat performance.

DTX432K SPECIFICATIONS

Module	DTX402
Pad Snare	7.5 inch pad
Tom1, 2	7.5 inch pad
Floor Tom	7.5 inch pad
Bass Drum	KP65
Bass Drum Pedal	FP6110A
Hi-Hat	10 inch pad
Hi-Hat Controller	HH65
Crash Cymbal	10 inch pad (Choke Function)
Ride Cymbal	10 inch pad

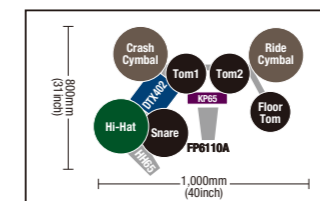

*Wiring not shown.

DTX402K

- Newly developed drum pads incorporating Yamaha's unique floating system.
- KU100 kick unit reduces noise when playing the bass drum.
- Choke-able crash cymbal pad.
- Ride cymbal pad produces the sound of the cymbal bell when hit strongly.

DTX402K SPECIFICATIONS

Module	DTX402
Pad Snare	7.5 inch pad
Tom1, 2	7.5 inch pad
Floor Tom	7.5 inch pad
Bass Drum	KU100
Bass Drum Pedal	KU100
Hi-Hat	10 inch pad
Hi-Hat Controller	DTX402K Hi-Hat Controller
Crash Cymbal	10 inch pad (Choke Function)
Ride Cymbal	10 inch pad

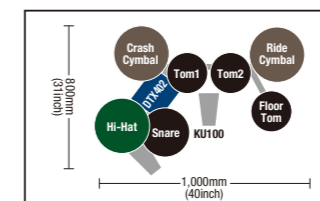

iOS/Android App DTX402 Touch



Price: free
Work with: DTX402 series
Stand alone: x
Device: iPhone, iPad, Android devices

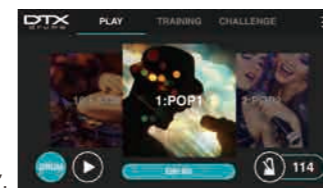

Get a Drummer's Certificate

If you can play all 10 practice songs without making a mistake, you will receive a "Drummer's Certificate".

Learn While Having Fun

There are 10 Training Modes designed to make you a better player, faster. The exercises are a fun way to learn to read drum music notation.

Simple and Intuitive Control

With a simple swipe, you can select and customize kits, song numbers, set up metronome and adjust the triggering parameters for your playing style.

iOS/Android App Rec'n'Share



Price: free
Work with: EAD10/DTX402 series
Stand alone: △
* Only practice functions usable.
Device: iPhone, iPad, Android devices



* Automatically analyze the tempo of songs selected from the music library of your device and add a click to match. You can also alter the tempo and use functions such as A-B repeat when practicing.

* After recording sound or video, you can cut unnecessary material from the beginning or end of clips and alter the volume balance of the sound and instruments.

* Upload your original videos to sites such as Youtube, Facebook, Dropbox, and Instagram easily.

DTX502 series



Using technology from our top-of-the-line kit, the affordable DTX502 series is designed for every drummer who wants to play for fun or serious practice.

DTX582K

The flagship of the 502 series, the DTX 582K features DTX-PADs for snare and toms, a real hi-hat trigger, large 3-zone cymbals, and the big KP100 kick pad, which can easily accommodate a double kick pedal. The superb feel of the DTX-PADs and the rock-solid stability of the KP100 make this an unbeatable kit in its class, perfect for performing on stage or extended practice sessions at home.



*Foot pedal not included.
*Wiring not shown.

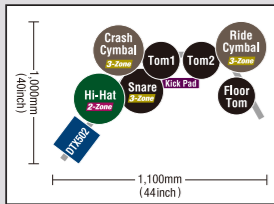

DTX582K SPECIFICATIONS

Module	DTX502
Pad Snare	XP80 3-zone Pad
Tom1, 2	XP70x2 1-zone Pad
Floor Tom	XP70 1-zone Pad
Crash Cymbal	PCY135 3-zone Pad
Ride Cymbal	PCY135 3-zone Pad
Hi-Hat	RHH135 2-zone Pad
(Hi-Hat stand)	HS650A
Kick	KP100
Rack	RS502

DTX532K

The DTX532K features the DTX-PAD for the snare, 532 real hi-hat trigger and large cymbals to give drummers a setup that more closely matches an acoustic set. The vertical-motion hi-hat greatly enhances the overall drumming experience and the dynamic sounds of the module bring your playing to life.



*Foot pedal not included.
*Wiring not shown.

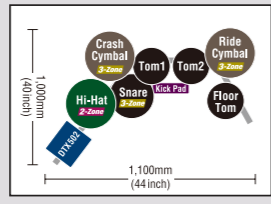

DTX532K SPECIFICATIONS

Module	DTX502
Pad Snare	XP80 3-zone Pad
Tom1, 2	TP70x2 1-zone Pad
Floor Tom	TP70 1-zone Pad
Crash Cymbal	PCY135 3-zone Pad
Ride Cymbal	PCY135 3-zone Pad
Hi-Hat	RHH135 2-zone Pad
(Hi-Hat stand)	HS650A
Kick	KP65
Rack	RS502

DTX522K

The centerpiece of a drummer's performance is the snare drum. This model features the DTX-PAD snare pad, which greatly enhances your practice sessions by giving you the proper response to improve your technique.



*Foot pedal not included.
*Wiring not shown.

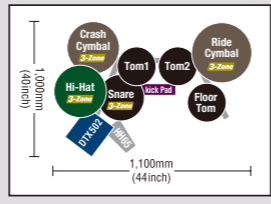

DTX522K SPECIFICATIONS

Module	DTX502
Pad Snare	XP80 3-zone Pad
Tom1, 2	TP70x2 1-zone Pad
Floor Tom	TP70 1-zone Pad
Crash Cymbal	PCY100 3-zone Pad
Ride Cymbal	PCY135 3-zone Pad
Hi-Hat	PCY100 3-zone Pad
(Hi-Hat Controller)	HH65
Kick	KP65
Rack	RS502

Build your dream kit!

Using any of the wide range of Yamaha pads, expand and customize your own unique setup.



One up two down Kit

All five-piece kits are not created equal - this is an all DTX-PAD set for the way you rock. Start with the DTX522K and add two extra crash cymbals with a pair each of PCY100 and CYAT500. Use the TPCL500 clamp to strategically position the TP70 pad for use as a cowbell, loop pad, or sound effect.



502 series Features

Powerful DTX502 Drum Trigger Module

The DTX502 has almost twice the wave ROM and over 250 more sounds than its predecessor and features new drum and cymbal samples from top VST developers that have been optimized for DTX. The increased memory offers more detailed articulations and more true variety in the DTX502's vast library of drum sounds. You can even import your own samples (and MIDI songs) for further expandability.

Advanced Technology Under The Hood

Using proprietary laser technology to analyze drum strokes, we precisely tuned the trigger settings on the DTX502 series resulting in a more natural feeling with laser accuracy. You also get advanced features from our higher end models like cymbal muting, natural cymbal swells, and smoother snare drumrolls so the kits respond to every nuance of your playing.

Updated Practice Functions With Scoring

New drum training functions are included to challenge you no matter your current skill level every time you practice. Working with these tools will help you improve the most important skills for drumming from rhythmic timing to pad accuracy and endurance. The system will even generate a score so you can track your progress as you improve.

New Design Offers Versatile Trigger and Upgrade Options

The DTX502 module is perfect for use in a "hybrid" kit with your acoustic drum hardware, and can be expanded with four additional pads or triggers. Pad upgrades let you build your dream kit as your skills improve. USB connectivity lets you connect to a PC.

The sound and feel make you think you're playing acoustic drums. The on-board training functions, the ability to load your own samples via USB, plus the ability to connect directly to a computer make the DTX700 series a serious tool for the modern drummer.



DTX700 series

DTX760K

Featuring larger DTX-PADs for the snare and toms with convenient control knobs to adjust the sound, this kit is the deluxe model in the 700 series. With the ability to import custom samples via USB your sounds will stay in step with the latest musical styles.



*Foot pedal not included.
*Wiring not shown.

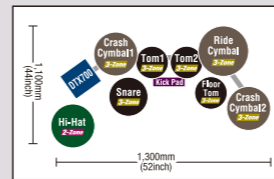

DTX760K SPECIFICATIONS

Module	DTX700
Pad Snare	XP120SD 3-zone Pad
(Snare stand)	SS662
Tom1,2	XP100Tx2 3-zone Pad
Floor Tom	XP120T 3-zone Pad
Crash Cymbal1,2	PCY135x2 3-zone Pad
Ride Cymbal	PCY155 3-zone Pad
Hi-Hat	RHH135 2-zone Pad
(Hi-Hat stand)	HS740A
Kick	KP100
Rack	RS700

DTX760K with Hardware

DTX components can also be used with standard acoustic drum hardware!



*Wiring not shown.

DTX760K with Hardware SPECIFICATIONS

Module	DTX700
Pad Snare	XP120SD 3-zone Pad
(Snare stand)	SS662S
Tom1,2	XP100Tx2 3-zone Pad
Floor Tom	XP120T 3-zone Pad
Crash Cymbal1,2	PCY135x2 3-zone Pad
Ride Cymbal	PCY155 3-zone Pad
Hi-Hat	RHH135 2-zone Pad
(Hi-Hat stand)	HS740A
Kick	KP100
Hardware	DFP9500C, SS662S, SS740S, HS740A, CH750x2, CH755, WS860Ax2

DTX720K

Combining the superior playability of the DTX-PADs, real hi-hat controller and natural sounds, this system is superb for authentic training to really improve your acoustic drumming skills.



*Foot pedal not included.
*Wiring not shown.

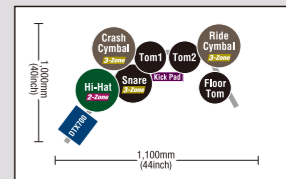

DTX720K SPECIFICATIONS

Module	DTX700
Pad Snare	XP80 3-zone Pad
Tom1, 2	XP70x2 1-zone Pad
Floor Tom	XP70 1-zone Pad
Crash Cymbal	PCY135 3-zone Pad
Ride Cymbal	PCY135 3-zone Pad
Hi-Hat	RHH135 2-zone Pad
(Hi-Hat stand)	HS650A
Kick	KP100
Rack	RS502

Features

No Compromise Sound Quality

There are a total of 1,396 sounds covering a broad spectrum of instruments, including an essential selection of Yamaha acoustic drum sounds like Oak Custom series, as well as percussion and effect sounds. It also contains a wide variety of sounds from Yamaha's famed MOTIF XF synthesizer. Used in combination with the DTX-PAD, the DTX700 module delivers even greater expressiveness and realism.

Import Original Voices Via The USB Jack

Using a USB memory device, it's easy to import your favorite voices (WAV/AIFF) into the DTX700. Once in the device you can edit and assign the voices to pads to create your own, original drum kit.

Hi-Hat With Real Playability

This full-fledged hi-hat system consists of a pad that sets onto the supplied hi-hat stand—the same type of stand typically used in an acoustic drum kit. This hi-hat pad system can play both open and closed sounds as well as a foot splash. It also uses a 2-zone design consisting of edge and bow sections, which add to its realistic feel and playability.

Use for Recording Or Music Production

The DTX700 easily connects to a computer via a USB cable (sold separately) making it a great for recording MIDI data into a DAW or for playing a VST sound source. Steinberg's Cubase AI is included with the kit so you can start creating music right away.

The ultimate fusion of natural response and advanced technology lets you express yourself anytime you feel the need to groove.



DTX900 series



DTX920K

The embodiment of Yamaha's signature obsession for quality. Providing the full natural expressiveness attainable only with the best kits, this set truly unleashes the drummer's musical potential.

DTX920K with Hardware

DTX components can also be used with standard acoustic drum hardware!



*Foot pedal not included.
*Wiring not shown.



*Wiring not shown.

DTX920K SPECIFICATIONS

Module	DTX900M	
Pad	Snare XP120SD	3-zone Pad
	(Snare stand) SS662	
	Tom1, 2 XP100T×2	3-zone Pad
	Floor Tom XP120T	3-zone Pad
	Crash Cymbal1, 2 PCY135×2	3-zone Pad
	Ride Cymbal PCY155	3-zone Pad
	Hi-Hat RHH135	2-zone Pad
	(Hi-Hat stand) HS740A	
	Kick KP100	
Rack	RS700	

DTX920K with Hardware SPECIFICATIONS

Module	DTX900M	
Pad	Snare XP120SD	3-zone Pad
	(Snare stand) SS662S	
	Tom1, 2 XP100T×2	3-zone Pad
	Floor Tom XP120T	3-zone Pad
	Crash Cymbal1, 2 PCY135×2	3-zone Pad
	Ride Cymbal PCY155	3-zone Pad
	Hi-Hat RHH135	2-zone Pad
	(Hi-Hat stand) HS740A	
	Kick KP100	
Hardware	DFP9500C, SS662S, SS740S, HS740A, CH750x2, CH755, WS860Ax2	

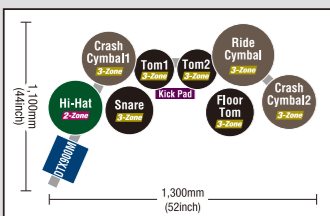

Features

Delivers Real Playability

Experience the ultimate in feel and playability with the 3-zone DTX-PAD used for snare and tom drums, also the hi-hat controlled with the hi-hat stand, 3-zone cymbal pads that produce different sounds according to where the pad is hit, the large kick pad, and more.

Add Original Sounds With Sampling

You can load data from an external source into the module then assign the voices to the pads to play. You can also sample external sound sources directly into the unit via the AUX IN jack, or even sample yourself playing. Once in the device, data can be processed with the onboard effects, etc., to create your own, original drum kit.

Outstanding Performance For Per-forming Live, Recording, Or Music Production

Authentic acoustic drum sounds, expertly engineered drum sounds, percussion sounds, and more; the DTX900 Drum Trigger Module provides a wide-ranging collection that covers nearly any musical style. Superior sound quality meets the demands necessary for stage or recording use. Accompanied with Steinberg's Cubase AI DAW application, all you need to do is connect the module to a computer with a USB cable (sold separately) and start creating music right away.

Unique DTX Functions Deliver Awe-Inspiring Expressive Stack

Powerful capabilities like the Stack Function, which layers multiple voices on a single pad and plays them simultaneously, and the Alternate Function, which changes the voice each time the pad is struck, are unique to DTX drums. These let you create original ways to play that are impossible to perform with acoustic drums.

DRUM TRIGGER



Attached to your acoustic drums, the DT50 Series professional drum triggers provide accurate triggering while maintaining the natural feel and sustain of your acoustic drums. The sleek chrome finish and durable solid die-cast metal body provide a tour level quality with a professional look. The dual-trigger snare trigger facilitates complete isolation between Head & Rim for dual-zone triggering.



Chrome finish and Yamaha Absolute lug-style design provides a clean, professional look.

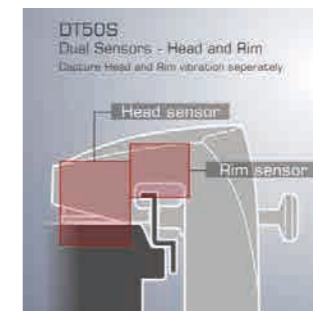

DT50S features dual trigger capability with complete isolation between head and rim triggering.

DT50S



DT50K



DTX-MULTI 12



The DTX-MULTI 12 is an electronic percussion pad equipped with 12 trigger pads and an onboard library of sounds that include drums, percussion, pitched instruments, ethnic instruments, DJ sounds, and sound effects. You can import 64MB of custom samples, expand the unit with five drum triggers or pads, or connect via USB to a computer. The DTX-MULTI 12 suits any playing style, and provides drummers at all levels with unlimited inspiration from its all-in-one design.

MULTI VOICES AND EFFECTS

The DTX-MULTI 12 comes loaded with a total of 1,277 voices that include an expansive collection of stunning voices and effects from our renowned MOTIF Series synthesizers plus a wealth of new percussion sounds. You can use this extensive palette of percussive tones to create custom kits that fit your playing needs.

MULTI MODES

Stick Mode, Hand Mode, Finger Mode. The DTX-MULTI 12 lets you choose the way you want to play and best express yourself.

MULTI ASSIGNMENTS

Up to four voices can be assigned to a single pad for simultaneous or sequential playback. You can also have voices that change according to your dynamics. This opens up a wide range of playing possibilities.

MULTI PATTERNS

A total of 128 phrase patterns covering a wide range of musical styles are included with the DTX-MULTI 12. User memory allocations are also provided so you can record your own patterns and assign them to the pads. A sophisticated click track function even lets you control the tempo live-off-the-floor.

MULTI PURPOSE

The DTX-MULTI 12 features make it flexible enough for Multiple applications. It's a great solution for anyone looking to:

- 1: Easily add electronics to an acoustic drum kit
- 2: Complement hand drums with a full palette of percussion sounds
- 3: Integrate electronic percussion and drums into their computer based music production system
- 4: Create a compact drum kit for portable playability



Option

Stand PS940
Module Attachment MAT1



APPLICATIONS FOR DTX/EAD

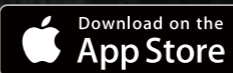
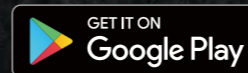

*** Device Requirement**
 • iOS device: An Apple Lightning to USB Camera Adapter / Camera Connection Kit is required.
 • Android device: OTG compatible device / USB OTG cable is required.
 For more information, visit the YAMAHA Web site.

	DTX700 Touch	DTX502 Touch	DTXM12 Touch	DTX402 Touch	Rec'n'Share	Song Beats
APP Title						
Price	free	free	free	free	free	free
Work with						
Standalone	×	×	○	×	△ *Only practice functions usable.	○
Device	iPhone / iPod touch / iPad*	iPhone / iPod touch / iPad*	iPad*	iPhone / iPod touch / iPad / Android devices*	iPhone / iPod touch / iPad / Android devices*	iPhone / iPod touch / iPad*
Concept	DTX700 Touch offers an innovative way of interacting with the Yamaha DTX700 series. It's now even easier to customise the sound that you want critically.	DTX502 Touch offers an innovative way of interacting with the Yamaha DTX502 series. It's now even easier to customise the sound that you want critically.	DTXM12 Touch is a dedicated iPad app that provides powerful support to drummers and percussionists who use the DTX-MULTI12 on-stage.	DTX402 Touch is a dedicated iOS/Android app for DTX402 series. The DTX402 Touch has 10 Training Modes and Challenge Mode designed to make you a better player, faster.	Rec'n'Share allows you to record audio and video along with songs from your music library and then share your performances with the world. It digitally enhances the way you practice, record and perform music.	Song Beats makes it easy to learn to play the drums along with your favorite songs. (10 demo songs are included. An Apple Lightning to USB Camera Adapter/Camera Connection Kit is required for grading)
Features	<p>KIT FINDER</p> <ul style="list-style-type: none"> Automatic recognition of music genre for music transferred to iPhone/iPad, and a function to recommend a drum kit to match the song from the drum kits contained in the DTX700. <p>DATA MANAGER</p> <ul style="list-style-type: none"> Data exchange with DropBox is possible. Direct access to browse YAMAHADTX.com enabling you to download and install new User Kits directly from YAMAHADTX.com. <p>GRAPHICAL MIXER & EFFECT SETTING</p> <ul style="list-style-type: none"> These functions enables you to take full control of built in mixer & effects with quick and easy access to the parameter that will let you build your dream sound. 	<p>KIT FINDER</p> <ul style="list-style-type: none"> Automatic recognition of music genre for music transferred to iPhone/iPad, and a function to recommend a drum kit to match the song from the drum kits contained in the DTX502. <p>DATA MANAGER</p> <ul style="list-style-type: none"> Data exchange with DropBox is possible. Direct access to browse YAMAHADTX.com enabling you to download and install new User Kits directly from YAMAHADTX.com. <p>HYBRID SETUP WIZARD</p> <ul style="list-style-type: none"> Hybrid setup wizard is your own personal assistant that can help you quickly and easily combine acoustic and electronic elements together to make one composite sound. 	<p>DISPLAY PAD ASSIGNMENTS</p> <ul style="list-style-type: none"> The DTXM12 Touch displays pad assignments using text and pictures and can also be used to confirm voice layers and function assignments. <p>CHANGE PAD ASSIGNMENTS</p> <ul style="list-style-type: none"> In addition to the DTX-MULTI12's built-in voices and functions, DTXM12 Touch lets you assign audio data (.wav, .aiff, .mp3, etc.) imported from Dropbox as well as content from your iPad's music library. <p>DISPLAY AND EDIT KIT LISTS</p> <ul style="list-style-type: none"> Using DTXM12 Touch, you can arrange kits to match your set list for convenient management of kit data for stage use. Kits can be edited from within the kit list, and the App Pad function makes it possible to switch kits smoothly on stage. 	<p>GET A DRUMMER'S CERTIFICATE</p> <ul style="list-style-type: none"> If you can play all 10 practice songs without making a mistake, you will receive a "Drummer's Certificate". <p>LEARN WHILE HAVING FUN</p> <ul style="list-style-type: none"> There are 10 Training Modes designed to make you a better player, faster. The exercises are a fun way to learn to read drum music notation. <p>SIMPLE AND INTUITIVE CONTROL</p> <ul style="list-style-type: none"> With a simple swipe, you can select and customize kits, song numbers, set up metronome and adjust the triggering parameters for your playing style. 	<p>PRACTICE FUNCTION</p> <ul style="list-style-type: none"> Tempo detection and add click with music, change the tempo and select sections to repeat. <p>RECORDING FUNCTION</p> <ul style="list-style-type: none"> Record, Mix and Edit Multi Track Audio and Video. <p>SHARE FUNCTION</p> <ul style="list-style-type: none"> Upload recorded Audio/Video to Youtube/Facebook/ Dropbox / Instagram etc. (*) <p>(*) The data uploaded to SNS is limited to your own original songs, sound sources, or those licensed from right holders.</p>	<p>VISUALIZE THE BEAT</p> <ul style="list-style-type: none"> The glowing rings indicate which drum to strike in realtime Mute / Solo the drums and test your skill <p>MIX IT UP</p> <ul style="list-style-type: none"> Mix the drums, freely adjust the tempo and loop a difficult section of the song <p>NEW SONGS</p> <ul style="list-style-type: none"> Import your own MIDI songs with iTunes file sharing

■ SPECIFICATIONS

MODEL	DTX920K	DTX760K	DTX720K	DTX582K	DTX532K	DTX522K	DTX452K	DTX432K	DTX402K
Snare	XP120SD for SNARE 	XP120SD for SNARE 	XP80 	XP80 	XP80 	XP80 	TP70S 	TP70S 	TP70S
Tom 1	XP100T for TOM 	XP100T for TOM 	XP70 	XP70 	XP70 	TP70 	TP70 	TP70 	TP70
Tom 2	XP100T for TOM 	XP100T for TOM 	XP70 	XP70 	XP70 	TP70 	TP70 	TP70 	TP70
Floor Tom	XP120T for TOM 	XP120T for TOM 	XP70 	XP70 	XP70 	TP70 	TP70 	TP70 	TP70
Kick Pad	KP100	KP100	KP100	KP100	KP65	KP65	KP65	KP65	KU100
HH Pad	RHH135 	RHH135 	RHH135 	RHH135 	RHH135 	PCY100 or	PCY100 or	HH65 	DTX402K Hi-Hat Controller
Crash Cymbal 1	PCY135 	PCY135 	PCY135 	PCY135 	PCY135 	PCY100 or	PCY100 or	PCY100 	PCY100
Crash Cymbal 2	PCY135 	PCY135 	—	—	—	—	—	—	—
Ride Cymbal	PCY155 	PCY155 	PCY135 	PCY135 	PCY135 	PCY135 	PCY135 	PCY135 	PCY135
Rack	RS700	RS700	RS502	RS502	RS502	RS502	RS502	DTX402 Series Rack	DTX402 Series Rack
Tone Generator	Voices: 1,115 drums + 211 melodies Drum Kit: 100 (50 user kits) Songs: 3 Demos, 44 Practices songs, 40 Pad songs	Voices: 1,268 drums + 128 melodies Drum Kit: 60 (10 user kits) *All of which may be edited and over written Songs: 2 Demos, 44 Practices songs, 17 Pad songs	Voices: 1,268 drums + 128 melodies Drum Kit: 60 (10 user kits) *All of which may be edited and over written Songs: 2 Demos, 44 Practices songs, 17 Pad songs	Voices: 691 drums + 128 melodies Drum Kit: 100 (50 user kits) Songs: 1 Demo, 37 Practices songs, 22 Pad songs, 40 User	Voices: 691 drums + 128 melodies Drum Kit: 100 (50 user kits) Songs: 1 Demo, 37 Practices songs, 22 Pad songs, 40 User	Voices: 691 drums + 128 melodies Drum Kit: 100 (50 user kits) Songs: 1 Demo, 37 Practices songs, 22 Pad songs, 40 User	Voices: 691 drums + 128 melodies Drum Kit: 100 (50 user kits) Songs: 1 Demo, 37 Practices songs, 22 Pad songs, 40 User	Voices: 287 drums + 128 melodies Drum Kit: 10 (all of which may be edited and overwritten) Songs: 10 songs	Voices: 287 drums + 128 melodies Drum Kit: 10 (all of which may be edited and overwritten) Songs: 10 songs
Expandability	You can add up to 5 pads	You can add up to 2 pads	You can add up to 3 pads	You can add up to 4 pads	You can add up to 4 pads	You can add up to 4 pads	You can add up to 4 pads	You can add up to 1 pads	You can add up to 1 pads
Input / Output									
Sampling / Cubase AI	○ / ○	× / ○	× / ○	× / ×	× / ×	× / ×	× / ×	× / ×	× / ×

MODULE

DTX900M



DTX700



DTX502



DTX900M SPECIFICATIONS

Tone Generator	
Voices	Drum and percussion: 1,115, Melodies: 211
Drum Kits	Preset: 50, User: 50, External: 1584 (or 99 x 16, in the external USB storage device)
Effects	Reverb: 9, Chorus: 19, Variation: 51 (Drum Kit), Insertion: 51 (AUX IN/SAMPLING IN), Master Effect: 9, Master EQ: 5 bands
Sequencer	
Note Capacity	Approx. 152,000 notes
Note Resolution	480 ppq (parts per quarter note)
Song Recording type	Real-time
Song Tracks	2 tracks
Songs	Demo: 3, Practice: 44, Pad: 40, User: 50
Sequence Format	Proprietary, SMF format 0
Audio Import	
Sampling	512MB (SDRAM built-in)
Samples	1,016
Sample Data Bits	16 bits
Sampling Time	44.1kHz: 6 min. 20 sec.
* Mono/Stereo	22.05kHz: 12 min. 40 sec. 11.025kHz: 25 min. 20 sec. 5.5125kHz: 55 min. 40 sec.
Sample formats	Proprietary, WAV, AIFF
Click	
Tempo	30 to 300 BPM, Tap Tempo supported.
Beat	1/4 to 16/4, 1/8 to 16/8, 1/16 to 16/16
Timing	Accent, Quarter note, Eighth note, Sixteenth note, Triplet
Training Functions	Measure break, Groove check, Rhythm gate
Others	
Connectors	<ul style="list-style-type: none"> • USB TO DEVICE/TO HOST • OUTPUT [L/MONO] (Standard mono phone) • OUTPUT [R] (Standard mono phone) • DIGITAL OUT [EIAJ CP1201, IEC60958, S/P DIF] • INDIVIDUAL OUTPUT 1 to 6 (Standard mono phone) • Trigger Input 1 to 9, 12 to 15 (Standard stereo phone, L: Trigger Input, R: Rim Switch) • Trigger Input 10 and 11 (Standard stereo phone, L: Trigger Input, R: Trigger Input) • HI-HAT CONTROL (Standard stereo phone) • AUX IN/SAMPLING IN (Standard stereo phone) • PHONES (Standard stereo phone) • MIDI IN/OUT
Dimensions, Weight	334 (W) x 285 (D) x 96 (H) mm, 3.6kg (13-5/32 x 11-15/64 x 3-25/32 inch, 7.9 lbs)
Accessories	Power Adaptor (PA-300B, or an equivalent), Module holder, Module holder fastening screws x 4, Owner's Manual, Data List, Cubase AI (Soft ware)

DTX700 SPECIFICATIONS

Tone Generator	
Voices	Drum and percussion: 1,268, Melodies: 128
Drum Kits	Preset: 50, User: 10* all of which may be edited and overwritten
Effects	Reverb: 6, Chorus: 6, Variation: 42 Kit EQ: 4 band, Master EQ: 3 bands
Sequencer	
Note Capacity	Approx. 152,000 notes
Note Resolution	480 ppq (parts per quarter note)
Song Recording type	Real-time replace
Song Tracks	1 tracks
Songs	Demo: 2, Practice: 44, Pad: 17, User: 30* all of which may be edited and overwritten
Sequence Format	Proprietary, SMF format 0
Audio Import	
Samples	500
Sample Data Bits	16 bits
Sampling Time	44.1kHz: 23 sec.
* Mono/Stereo	22.05kHz: 46 sec. 11.025kHz: 1 min. 32 sec. 5.5125kHz: 3 min. 4 sec.
Sample formats	WAV, AIFF
Click	
Tempo	30 to 300 BPM, Tap Tempo supported.
Beat	1/4 to 16/4, 1/8 to 16/8, 1/16 to 16/16
Timing	Accent, Quarter note, Eighth note, Sixteenth note, Triplet
Training Functions	Measure break, Groove check, Rhythm gate
Others	
Connectors	<ul style="list-style-type: none"> • USB TO DEVICE/TO HOST • OUTPUT [L/MONO] (Standard mono phone) • OUTPUT [R] (Standard mono phone) • Trigger Input 1 to 8, 11 (Standard stereo phone, L: Trigger Input, R: Rim Switch) • Trigger Input 9 and 10 (Standard stereo phone, L: Trigger Input, R: Trigger Input) • HH-KICK (Standard stereo phone) • HI-HAT CONTROL (Standard stereo phone) • AUX IN (Stereo Mini) • PHONES (Standard stereo phone) • MIDI IN/OUT
Dimensions, Weight	277 (W) x 213 (D) x 95 (H) mm, 1.5kg (10-29/32 x 8-25/64 x 2-3/4 inch, 3.31 lbs)
Accessories	Power Adaptor (PA-150, or an equivalent), Module holder, Module holder fastening screws x 4, Owner's Manual, Data List, Cubase AI (Soft ware)

DTX502 SPECIFICATIONS

Tone Generator	
Voices	Drum and percussion: 691, Melodies: 128
Drum Kits	Preset: 50, User: 50*
Effects	Reverb: 9, Master EQ: 2 bands
Sequencer	
Note Capacity	Approx. 104,000 Notes*
Note Resolution	96 ppq (parts per quarter note)
Song Recording type	Song Recording type
Real-time replace	Real-time replace
Song Tracks	1 track
Songs	Demo: 1, Practice: 37, Pad: 22, User: 40
Sequence Format	Proprietary, SMF format 0/1
Audio Import	
Samples	20*
Sample Data Bits	16 bits
Sampling Time	44.1kHz: 12 sec
Sequence Formats	WAV, AIFF
Click	
Tempo	30 to 300 BPM, Tap Tempo supported.
Beat	1/4 to 16/4, 1/8 to 16/8, and 1/16 to 16/16
Timing	Accent, Quarter note, Eighth note, Sixteenth note, Triplet
Training Functions	Groove Check, Rhythm Gate, Measure Break, Tempo Up/Down, Change Up, Pad Gate, Part Mute, Fast Blast
Others	
Connectors	<ul style="list-style-type: none"> • OUTPUT [L/MONO] (Standard mono phone) • OUTPUT [R] (Standard mono phone) • Trigger Input 1, 5, 6, 9 (Standard stereo phone, L: Trigger Input, R: Rim Switch) • Trigger Input 2, 3, 4, 7 (Standard stereo phone, L: Trigger, R: Trigger) • HI-HAT CONTROL (Standard stereo phone) • AUX IN (Stereo Mini) • PHONES (Standard stereo phone) • USB TO HOST
Dimensions, Weight	251 (W) x 130 (D) x 48 (H) mm, 610g (9-7/8 x 5-1/8 x 1-7/8 inch, 1.34 lbs)
Accessories	Power Adaptor (PA-130A, or an equivalent), Module holder, Module holder fastening screws x 2, Owner's Manual

* Total memory capacity of 1MB.

PAD Snare / Tom / Cymbal / Hi-Hat / Kick



XP120SD **3-Zone Pad**
Size: 12-inch Snare



XP120T **3-Zone Pad**
Size: 12-inch Tom



XP100SD **3-Zone Pad**
Size: 10-inch Snare



XP100T **3-Zone Pad**
Size: 10-inch Tom



XP80 **3-Zone Pad**
Size: 8-inch Snare / Tom



XP70 **1-Zone Pad**
Size: 7-inch Snare / Tom



TP70S **3-Zone Pad**
Size: 7.5-inch Snare / Tom



TP70 **1-Zone Pad**
Size: 7.5-inch Snare / Tom



PCY155 **3-Zone Pad**
Size: 15-inch



PCY135 **3-Zone Pad**
Size: 13-inch



PCY100 **2-Zone / 3-Zone Pad**
Size: 10-inch



RHH135 **2-Zone Pad**
Size: 13-inch



HH65



KP65



KU100



KP100 Size: 10-inch

PCY95AT **1-Zone Pad**

Size: 10-inch Cymbal & Attachment



RACK SYSTEM

RS700

Size: 1,346(W) x 766.3(D) x 835(H) mm
(53 x 30 x 33 inch)
▶ DTX 920K / 760K



RS502

Size: 1,196(W) x 528.3(D) x 812.3(H) mm
(47 x 21 x 32 inch)
▶ DTX 720K / 582K / 532K / 522K

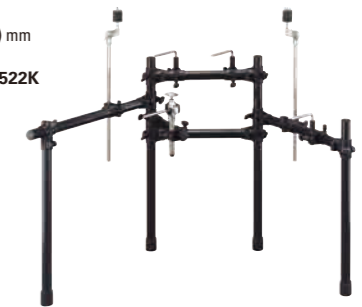

OPTION

Cymbal & Attachment CYAT500



Clamp for tom holder/ cymbal attachment with an adaptor RCL500



Diameter : with the adapter, 16.0mm,
without the adapter, 22.2mm

Tom Holder (w/Clamp) TPCL500

