



**YAMAHA**

**PERSONAL ELECTRONIC PIANO**

*YPP-55*

**Owner's Manual**

**Bedienungsanleitung**

**Mode d'emploi**

**Manual del usuario**

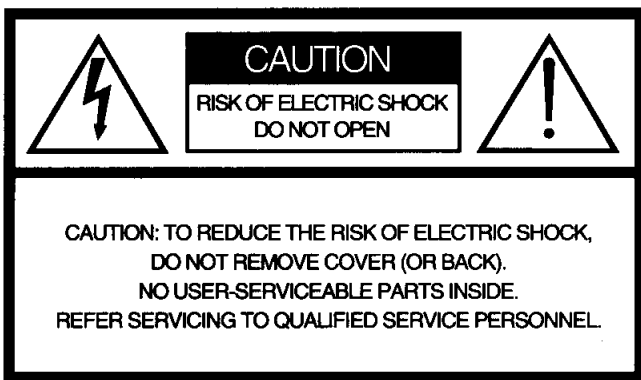

See bottom of Keyboard enclosure for graphic symbol markings

The lightning flash with arrowhead symbol, within an equilateral triangle, is intended to alert the user to the presence of uninsulated "dangerous voltage" within the product's enclosure that may be of sufficient magnitude to constitute a risk of electric shock to persons.

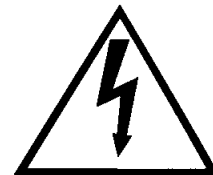

The exclamation point within an equilateral triangle is intended to alert the user to the presence of important operating and maintenance (servicing) instructions in the literature accompanying the product.



## IMPORTANT SAFETY AND INSTALLATION INSTRUCTIONS

INFORMATION RELATING TO POSSIBLE PERSONAL INJURY, ELECTRIC SHOCK, AND FIRE HAZARD POSSIBILITIES HAS BEEN INCLUDED IN THIS LIST.

**WARNING** - When using electronic products, basic precautions should always be followed, including the following:

1. Read all Safety and Installation Instruction, Explanation of Graphical Symbols, and assembly instructions (where applicable) **BEFORE** using your Yamaha electronic product. Check unit weight specifications before you attempt to move this instrument!
2. **Main Power Supply Verification:** Your Yamaha electronic product has been manufactured specifically for the main supply voltage used in your area. If you should move, or if any doubt exists, please contact your dealer for instructions. The main supply voltage required by your electronic product is printed on the name plate. For name plate location, see "Power Supply (page 2)" item.
3. This product may be equipped with a polarized line plug (one blade wider than the other). This is a safety feature. If you are unable to insert the plug into the outlet, contact an electrician to replace your obsolete outlet. Do not defeat the safety purpose of the plug.
4. **WARNING-**Do NOT place objects on your electronic products' power cord or place the unit in a position where anyone could trip over, walk over, or roll anything over cords of any kind. Do NOT allow your electronic product or its bench to rest on or be installed over cords of any type. Improper installations of this type create the possibility of a fire hazard and/or personal injury.
5. **Environment:** Your electronic product should be installed away from heat sources such as a radiator, heat registers and/or other products that produce heat. Additionally, the unit should not be located in a position that exposes the cabinet to direct sunlight, or air currents having high humidity or heat levels.
6. Your Yamaha electronic products should be placed so that its location or position does not interfere with its proper ventilation.
7. Some Yamaha electronic products may have benches that are either a part of the product or supplied as an optional accessory. Some of these benches are designed to be dealer assembled. Please make sure that the bench is stable before using it. The bench supplied by Yamaha was designed for seating only. No other uses are recommended.
8. Some Yamaha electronic products can be made to operate with or without the side panels or other components that constitute a stand. These products should be used only with the components supplied or a cart or stand that is recommended by the manufacturer.
9. Do not operate for a long period of time at a high volume level or at a level that is uncomfortable. If you experience any hearing loss or ringing in this ears, you should consult an audiologist.
10. Do not use your Yamaha electronic product near water or in wet environments. For example, near a swimming pool, spa, or in a wet basement.
11. Care should be taken so that objects do not fall, and liquids are not spilled, into the enclosure through openings.
12. Your Yamaha electronic product should be serviced by a qualified service person when:
  - a. The power-supply cord or plug has been damaged: or
  - b. Objects have fallen, or liquid has been spilled into the product: or
  - c. The product has been exposed to rain: or
  - d. The product does not operate, exhibits a marked change in performance: or
  - e. The product has been dropped, or the enclosure of the product has been damaged.
13. When not in use, always turn your Yamaha electronic product "OFF". The power-supply cord of the product should be unplugged from the outlet when it is to be left unused for a long period of time. Note: In this case, some units may lose some user programmed data. Factory programmed memories will not be affected.
14. Do not attempt to service the product beyond that described in the user-maintenance instructions. All other servicing should be referred to qualified service personnel.
15. **Electromagnetic Interference (RFI).** This series of Yamaha electronic products utilizes digital (high frequency pulse) technology that may adversely affect Radio/TV reception or the operation of other devices that utilize digital technology. Please read FCC Information (page 83) for additional information.

PLEASE KEEP THIS MANUAL  
FOR FUTURE REFERENCE!

**Owner's Manual**

Page 3-22

**Bedienungsanleitung**

Seite 23-42

**Manuel d'emploi**

Pages 43-62

**Manual del usuario**

Páginas 63-81

**C**ongratulations, and thank you for buying the YAMAHA YPP-55. We are sure you will be pleased with the natural sound and easy operation of this keyboard. Features include AWM technology (for a clear, realistic sound), stereo sound, eight different voices, touch-sensitive keys, recording capability, and much more. Please read this manual to learn how to best use and enjoy your new instrument. We wish you many years of musical pleasure with your YPP-55.

## CONTENTS

<b>1. BEFORE PLAYING</b> .....	<b>4</b>
A. Power Supply .....	4
B. Setting the Music Stand .....	5
C. Using the Foot Switch .....	5
D. Using Headphones .....	5
E. Connecting YPP-55 to another Audio System .....	5
<b>2. PLAYING</b> .....	<b>6</b>
A. Basic Playing Operation .....	6
B. Demonstration Play .....	7
<b>3. PLAYING TIPS &amp; FEATURES</b> .....	<b>8</b>
A. Touch Sensitivity .....	8
B. Using the Metronome .....	8
C. Transposition .....	8
D. Fine Tuning .....	9
<b>4. PERFORMANCE MEMORY</b> .....	<b>10</b>
A. Recording Preparations .....	10
B. Recording .....	10
C. Playback .....	11
<b>5. MIDI</b> .....	<b>12</b>
A. What is MIDI? .....	12
B. Types of MIDI Information .....	13
C. MIDI Channels .....	15
D. Applications .....	16
<b>MAINTENANCE</b> .....	<b>20</b>
<b>TROUBLESHOOTING</b> .....	<b>20</b>
<b>SPECIFICATIONS</b> .....	<b>21</b>
<b>MIDI IMPLEMENTATION CHART</b> .....	<b>82</b>

# 1. BEFORE PLAYING

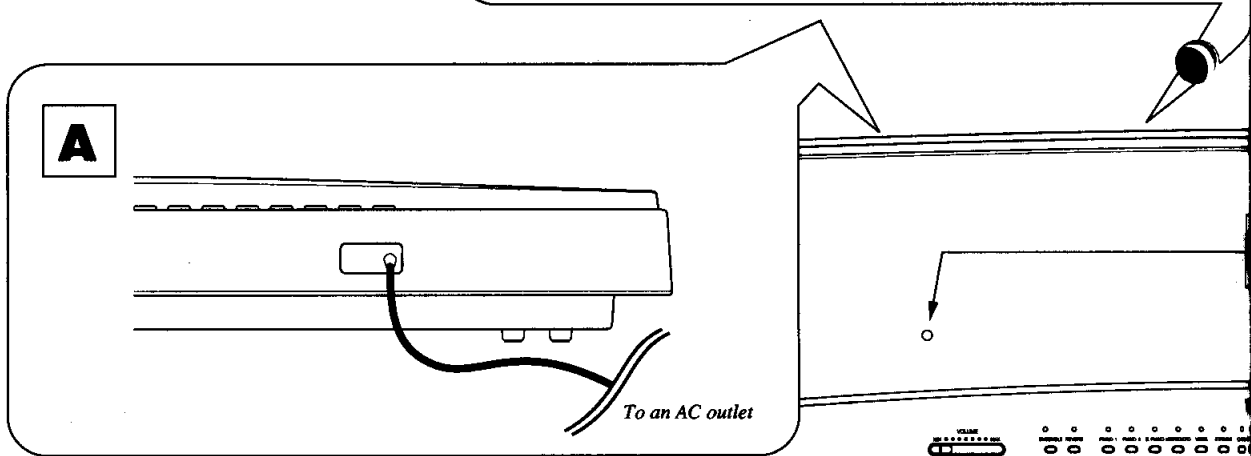
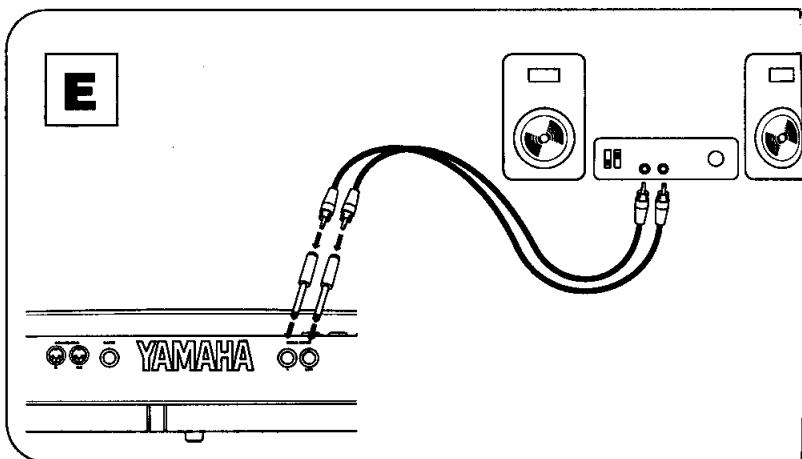

## A Power Supply

Be sure the POWER switch is not in the ON position (pushed in) and connect the power plug to an AC current. Also, remember never to pull on the power cable itself when disconnecting it from the outlet or when relocating the YPP-55, as it will cause disconnection of the cable.

- \* Your YPP-55 is designed to meet the standard voltage of your area. Make sure that your local AC mains voltage matches the power requirement specified on the name plate on the bottom panel of the instrument. If you have any doubts about voltage compatibility, consult your local Yamaha dealer. If you plan to use the instrument in an area of a different voltage, be sure to use an appropriate converter.

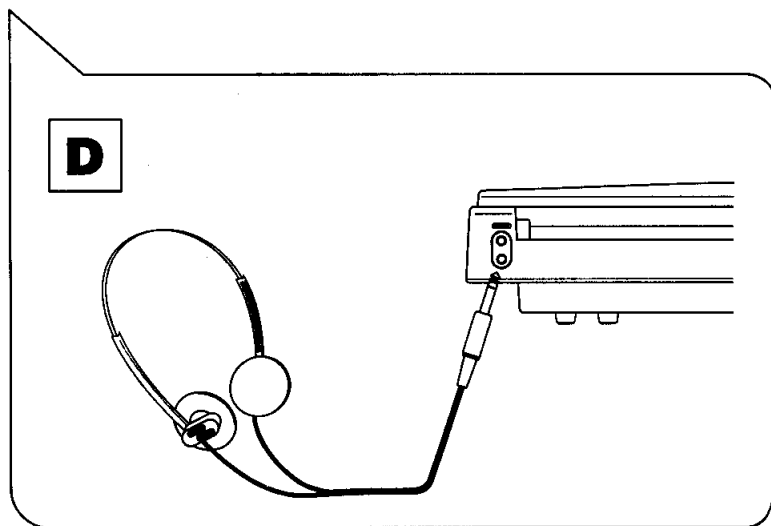

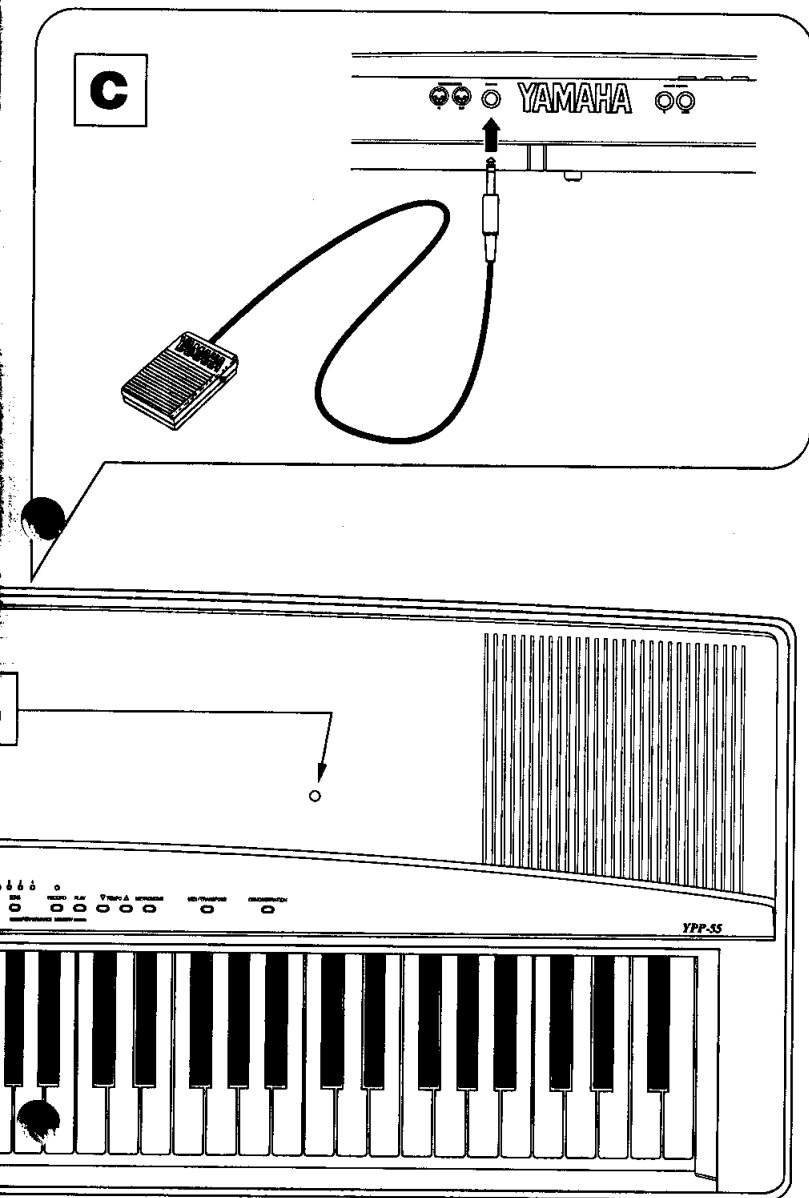

### **B** Setting the Music Stand

Insert both ends of the supplied music stand into the 2 holes located on the top panel next to the speakers.

### **C** Using the Foot Switch

Connect the supplied foot switch to the DAMPER jack on the rear panel. If you depress the foot switch while playing, you can sustain the sound.

### **D** Using Headphones

There are 2 HEADPHONES jacks on the left of the front panel of the YPP-55. Connecting your headphones to the HEADPHONES jack(s) turns off the speakers, so 1 or 2 people can practice and listen without disturbing anybody else.

### **E** Connecting YPP-55 to another Audio System

If you want more volume, connect the L/L+R and R AUX. OUT jacks of the YPP-55, using suitable cables, to the LINE IN's of your stereo system or similar device. If the device is a mono audio system (keyboard amplifier, etc.) use only the L/L+R AUX. OUT jack of the YPP-55. The combined L+R sound will be output from the keyboard.

## 2. PLAYING

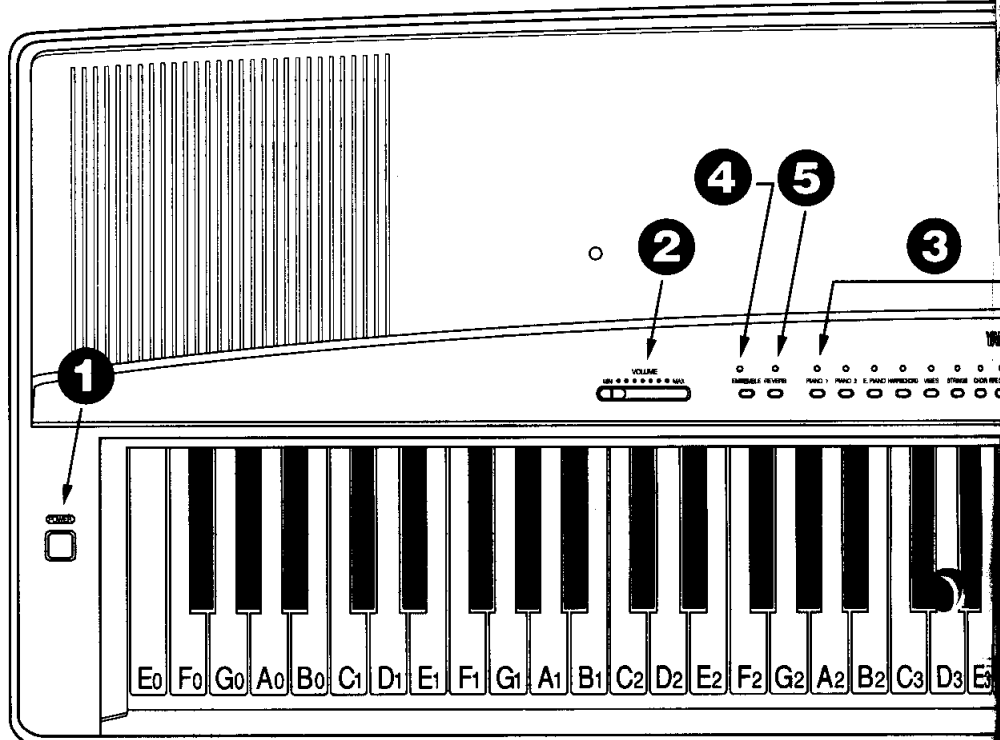

### A. Basic Playing Operation

#### 1) Power

When all the necessary connections have been made, turn on the POWER switch ❶. When the YPP-55 is first turned on, REVERB, PIANO 1 and SONG 1 are automatically selected, and corresponding indicators will light up.

#### 2) Volume

Adjust the volume with the VOLUME slide control ❷. This slider controls the speakers' and headphones' volume, as well as the output level of the AUX. OUT jacks.

#### 3) Selecting Voices

Select the sound you wish to play with by pressing one of the 8 Voice Select buttons ❸. The corresponding indicator will light up.

#### 4) Playing

Normally you can play up to 16 notes simultaneously except when using PIANO 2 and HARPSICHORD, which can play up to 32 notes at a time.

\* The tone of some voices may change slightly at one or more points on the Keyboard. This is due to the way in which the voice waveforms were initially sampled and is normal.

#### 5) Ensemble

To get a richer, fuller sound, press the ENSEMBLE button ❹, and the indicator above the button will light up. To turn off the effect, press the button once again.

\* When the Ensemble effect is on, only 16 notes can be played simultaneously, regardless of the selected voice.

#### 6) Reverberation

When the YPP-55 is turned on, the Reverb effect is automatically applied, as you can see by the lit indicator above the REVERB button ❺. This effect makes the instrument sound like it is being played in a concert hall. If you wish to turn off the Reverb, press the REVERB button again. To turn the effect back on, press this button once again.

\* Reverb depth varies according to each voice.

\* Reverb and Ensemble effects can not be applied to the metronome sound.

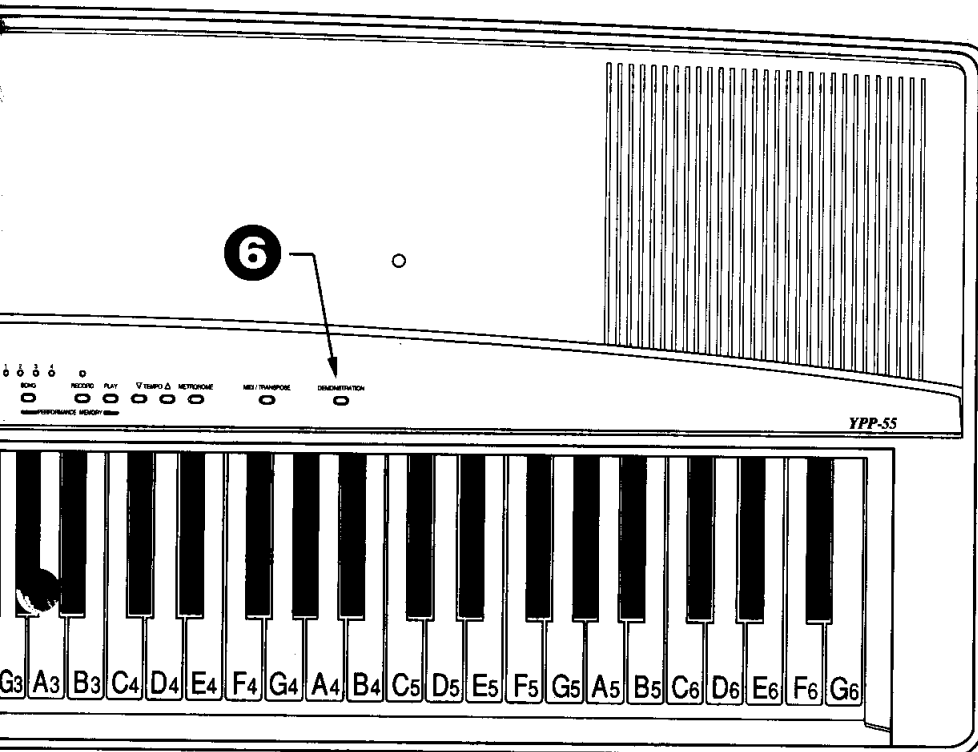

## B. Demonstration Play

### 1) Listening to the Demonstration

The YPP-55 has a demonstration song for each voice. Press the yellow DEMONSTRATION button **6**, and the demonstration song for each voice will be played in order from PIANO 1 to PIPE ORGAN. This sequence is repeated indefinitely.

To stop the performance, press the DEMONSTRATION button again.

- \* You can play along on the keyboard during demonstration play, in any selected voice.
- \* The demonstration songs will not be output as MIDI performance messages (See section 5, MIDI).
- \* During demonstration play, the Performance Memory and Metronome functions (explained later) will not operate.

### 2) Playing Individual Demonstration Songs

If you wish to play the Demonstration Songs individually, first press the DEMONSTRATION button. While holding it down, press one of the Voice Select buttons. The song corresponding to the selected voice will be played once.

If you wish to stop the performance, press the DEMONSTRATION button again.

VOICE	SONG NAME	COMPOSER
PIANO 1	PIANO SONATA K.V. 331 Var. 6	W. A. MOZART
PIANO 1	MOMENTS MUSICAUX, Opus94 No. 3 F minor	SCHUBERT
E. PIANO	—————	Yamaha Original
HARPSICHORD	INVENTION No. 8	J. S. BACH
VIBES	—————	Yamaha Original
STRINGS	SERENADE C dur Opus48	TSCHAIKOWSKY
CHOIR	—————	Yamaha Original
PIPE ORGAN	TOCCATA and FUGUE in D minor	J. S. BACH



# 3. PLAYING TIPS & FEATURES

## A Touch Sensitivity

The YPP-55 is touch sensitive, which means that the sound changes according to the player's touch. If you use a stronger touch (i.e. play harder), not only does the sound get louder, but the timbre is also affected.

To adjust the sensitivity, press and hold the F<sup>#</sup> 6 and G6 keys (highest two of the keyboard), then press one of the following Voice Select buttons: PIANO 1 (Range 1), PIANO 2 (Range 2), E. PIANO (Range 3).

- The range 1 setting allows maximum tone volume to be produced with a relatively light touch of the keys.
- The range 2 setting produces a fairly "standard" keyboard response.
- The range 3 setting requires that the keys be played quite hard to produce maximum tone volume.

We suggest you practice using this feature to fine-tune your touch on the YPP-55, so as to achieve maximum dynamic control and musical expression.

\* When the YPP-55 is turned on, the range 2 setting is automatically selected.

## B Using the Metronome

To activate the metronome, press the METRONOME button 7. The initial tempo, after the instrument has been turned on, is always 120 beats per minute. The two TEMPO buttons 8 are used to adjust the tempo. To increase the tempo, press the TEMPO ▲ button several times, or hold it down until the desired tempo is reached. To decrease the tempo, follow the same procedure with the TEMPO ▼ button. Pressing both TEMPO buttons at

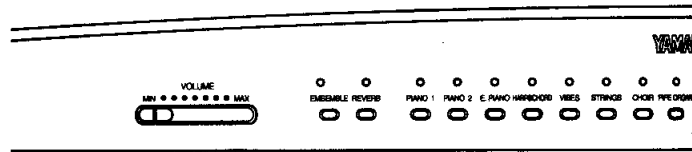

the same time will bring the tempo back to 120. The range of the metronome is from 40 to 280 beats per minute. To turn off the metronome, press the METRONOME button again.

You can use the metronome to help rhythmically tighten up your playing, for practicing sections of music accurately at different speeds, or as a guide while you are recording.

\* Tempos of the demonstration songs cannot be changed. After a demo song is stopped, The metronome tempo will automatically return to 120beats per minute (same as when power turned on).

## C Transposition

The overall pitch of the YPP-55 can be transposed up or down as far as 6 semitones (half steps) in either direction. Transposition occurs in 100 cent steps (1 semitone).

## D

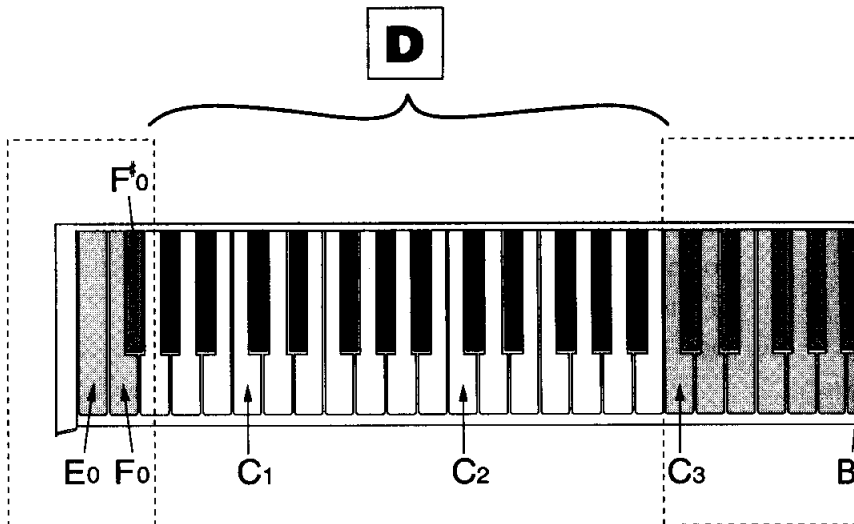

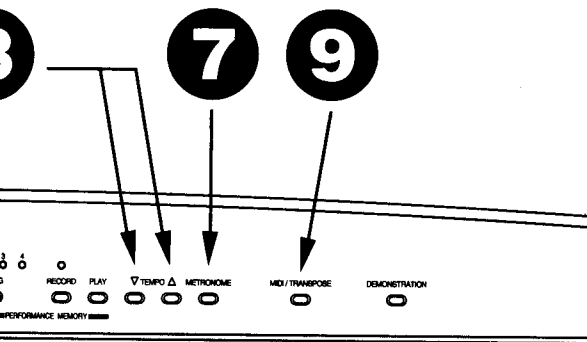

You can use the Transposition function to play a passage of music in several different keys, without actually changing the notes you play. Similarly, if you have to do some playing (for instance, accompanying or improvising) in a difficult key, you can transpose the YPP-55, so that the played C major scale (i.e. the white keys) will sound like a scale in the desired key.

### 1) Procedure

First, press and hold down the MIDI/TRANPOSE button 9. Then, press one of the F<sup>#</sup> 4 to F<sup>#</sup> 5 keys, which corresponds to the desired key.

PRESS	F <sup>#</sup> 4	G4	G <sup>#</sup> 4	A4	A <sup>#</sup> 4	B4	C <sup>#</sup> 5	D5	D <sup>#</sup> 5	E5	F5	F <sup>#</sup> 5
TRANPOSED TO KEY OF	F	G	G <sup>#</sup>	A	A <sup>#</sup>	B	C <sup>#</sup>	D	D <sup>#</sup>	E	F	F <sup>#</sup>

when played in C major (i.e. white keys only)

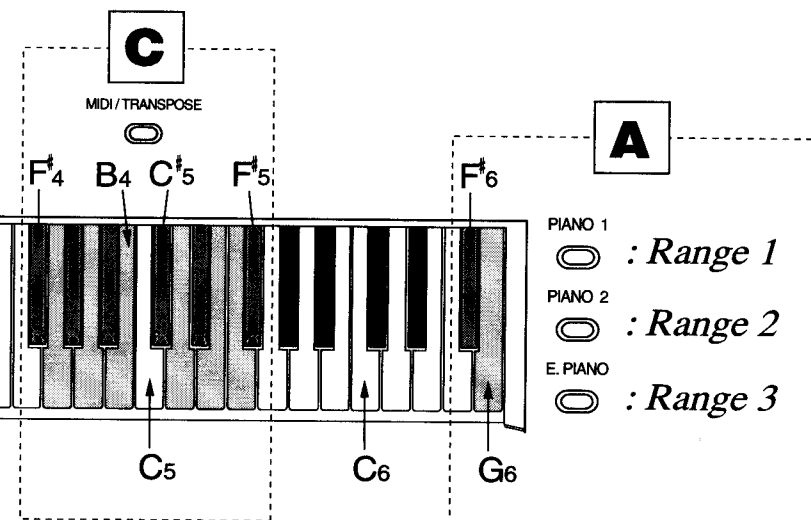

### 2) Returning to the Standard Pitch

To bring the YPP-55 back to the standard pitch (Key of C), press the MIDI/TRANPOSE button, and while holding it down, press the C5 key. Or, you can turn off the POWER switch, then turn it on again after a few seconds.

### D Fine Tuning

This function is very useful if you are playing in a band or other ensemble. It allows you to tune your instrument with the others. The YPP-55 can be fine-tuned up or down up to a quarter tone (+/-50 cents). You can also use the Fine Tuning function in conjunction with the Transposition function, in either order.

#### 1) Raising the Pitch

While holding down both the E0 and F0 keys, press any one of the C3 to B3 keys. Each time a key is pressed, the pitch will be raised, up to a maximum of 50 cents.

#### 2) Lowering the Pitch

While holding down both the E0 and F<sup>#</sup> 0 keys, press any one of the C3 to B3 keys. Each time a key is pressed, the pitch will be lowered, up to a maximum of 50 cents.

#### 3) Returning to the Standard Pitch (A3=440Hz)

While holding down the E0, F0 and F<sup>#</sup> 0 keys simultaneously, press any one of the C3 to B3 keys. Or, you can turn off the POWER switch, then turn it on again after a few seconds.

# 4. PERFORMANCE MEMORY

The YPP-55 Performance Memory function allows you to record, and play back, up to 4 of your original songs.

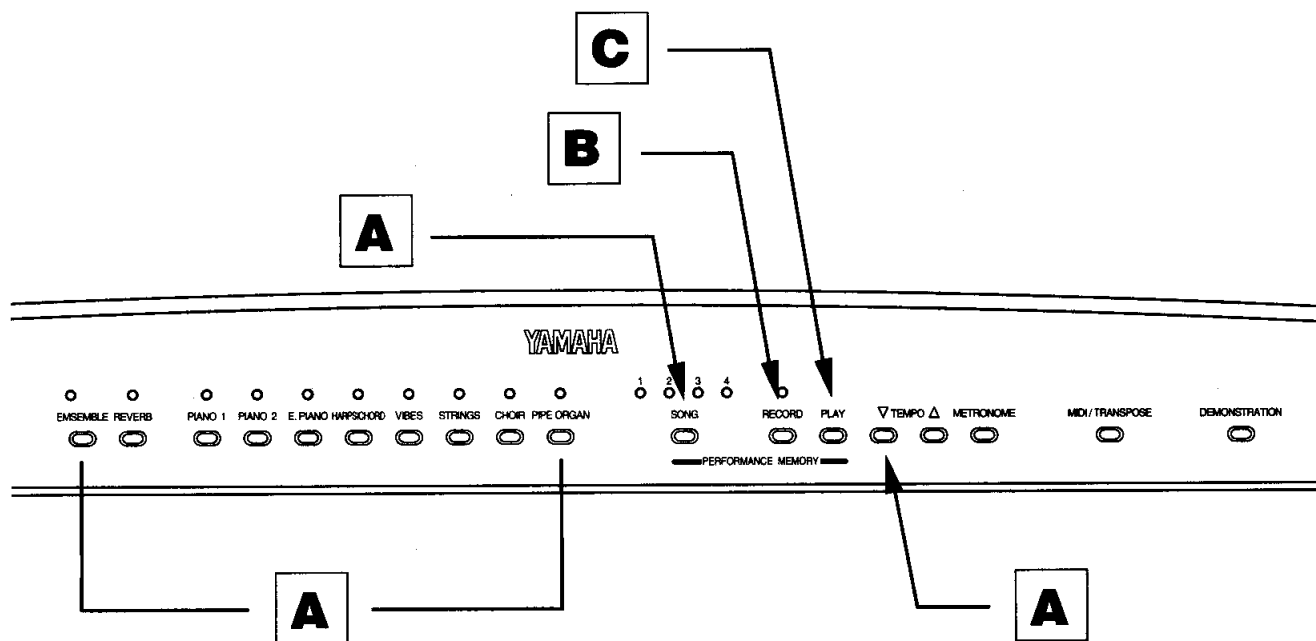

## A Recording Preparations

**Step 1:** First, select a song number you wish by repeatedly pressing the SONG button until the appropriate indicator (1, 2, 3 or 4) lights up.

**Step 2:** Next, select the voice you want by pressing the desired Voice Select button. Of course you can add Reverb and/or Ensemble effects, by pressing their buttons, if not already on.

**Step 3:** If you wish to use the metronome as a guide, press the METRONOME button to start the beat, then use the two TEMPO buttons to increase or decrease the current tempo to desired speed.

## B Recording

### 1) Procedure

Press the red RECORD button. The RECORD indicator will light up, and recording will start as soon as you play the first note of your song (The RECORD indicator will start blinking). Your performance will be stored in the YPP-55 internal memory. To finish recording, press the RECORD button again, and recording automatically stops.

## 2) Recorded Events and Memory Capacity

The Performance Memory considers each of the following actions as a recorded event:

- Voice selection (when/which voice selected)
- Reverb on/off (when button pressed)
- Ensemble on/off (when button pressed)
- Tempo changes (when/how much changed)
- Notes played (when/which note/how strongly played)
- Sustain on/off (when foot switch depressed/released)

\* The metronome sound is not recorded.

The total number of recorded notes that can be stored in the Performance Memory is up to approximately 1,500. When the memory capacity has been exceeded, the RECORD indicator automatically turns off, which signals that what you are playing is no longer being recorded.

- \* If you wish to record a long song, you may have to make some memory space by clearing dispensable song material. This is done by selecting the song(s) you wish to clear, and recording just one note. Now you can begin to record your long performance.
- \* Recorded songs are retained in the Performance Memory for about one week even if the YPP-55 is not turned on. To keep the songs in memory for longer periods, turn the POWER switch ON briefly at least once a week.

## **C** Playback

### 1) Procedure

To listen to the song you have recorded, press the PLAY button and the appropriate SONG indicator starts blinking. The YPP-55 will play back your song in the voice you selected when recording. To stop playback, press the PLAY button again.

- \* You can change the Ensemble, Reverb, and Tempo settings during playback.
- \* You cannot change the recorded voice to another during playback.

### 2) Tips

You can play along with your played-back performance, in the same or a different voice. For example, if you've recorded and are playing back a busy piano passage, you might try playing along with some slow sustained String chords, to fill out the sound.

# 5. MIDI

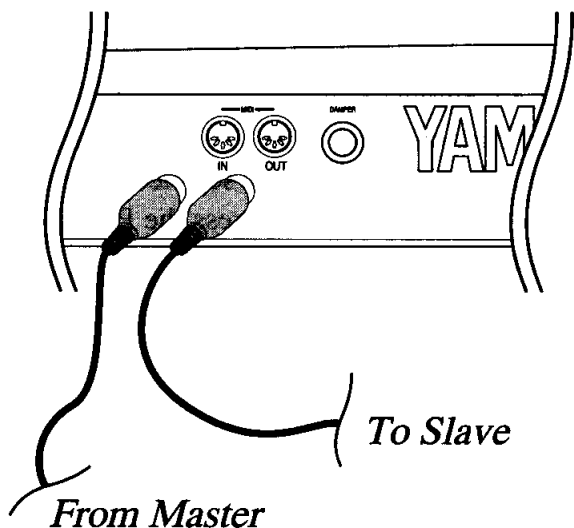

## A. What is MIDI?

The YPP-55 is a MIDI-equipped keyboard. MIDI (Musical Instrument Digital Interface) is a worldwide standard for communicating performance information between electronic musical instruments. With MIDI, the YPP-55 can control, and be controlled by, other MIDI-equipped instruments, such as synthesizers, sequencers and drum machines.

In a simple MIDI setup between two instruments, the instrument which is controlling is called the Master, and the instrument being controlled is called the Slave (Diagram A). You can also set up the two instruments so that they control each other, i.e. both machines are simultaneously Masters and Slaves (Diagram B). To connect the YPP-55 to another MIDI-equipped instrument, use the MIDI-IN or MIDI-OUT jacks on the rear panel, and join the instruments as shown in Diagram A or B.

DIAGRAM A

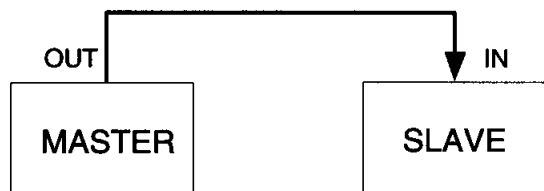

DIAGRAM B

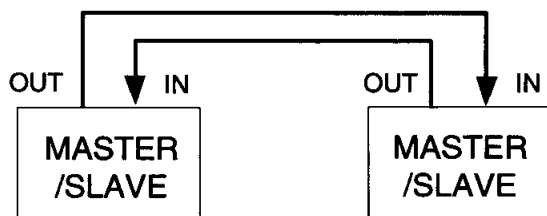
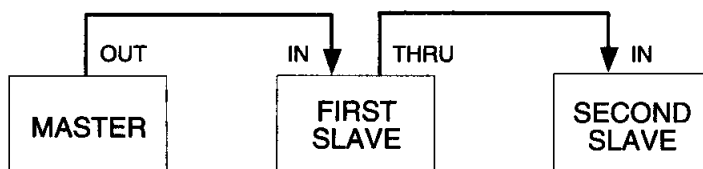

Diagram A depicts a “One-Way” connection, and Diagram B depicts a “Hand-Shaking” connection. All the following MIDI explanations will relate to these terms, as well as to the terms Master and Slave. So please be clear about these concepts before proceeding.

*Note: If you connect more than two instruments, the third instrument becomes the second Slave. To do this, make an additional One-Way connection from the MIDI-THRU jack of the first Slave to the MIDI-IN jack of the second Slave:*

DIAGRAM



At this time, the first Slave simply transmits, from its MIDI-THRU jack, the information received at its MIDI-IN jack. In this way, a Master can control two Slaves simultaneously.

*Note: Some MIDI instruments, such as the YPP-55, are not equipped with a MIDI-THRU jack, so are best suited to be the final Slave in a MIDI chain.*

\* MIDI is a uniform standard which defines the methods for transmission/reception of various performance information. However, each MIDI instrument does not always carry a complete range of MIDI features. For instance, a MIDI-equipped drum machine would have rhythmic features (i.e. start/stop, etc.) for synchronized performance which a simple keyboard would not. So, simply making the MIDI connection is not enough. It is important to understand the MIDI capabilities of each instrument to obtain best results. To find the MIDI specifications of a

device, refer to its MIDI implementation chart. The chart for the YPP-55 is found on 82 page of this manual.

## B. Types of MIDI Information

What kind of information is communicated by MIDI? The most universal is information about the notes being performed (or played back) from the Master. This is called "Note On" message, which includes information about the key being depressed (transmitted as MIDI note number), and, in the case of touch sensitive instruments such as the YPP-55, the velocity (speed) of depression (transmitted as velocity data). For instance, when the YPP-55 is set up as a Master, playing something on it will activate the sound module of the Slave, and you will hear, simultaneously, the voices of both instruments as you play. If your Slave instrument is equipped to receive velocity data, the volume and timbre of its voice will also vary according to your performance.

In addition to **Note On** information, the YPP-55 is also equipped to deal with Program Change and Control Change messages.

### 1) Program Change Message

Program Change message is used to change voices on a Slave instrument. For instance, with the YPP-55 set up as a Master, if you select one of its voices, a Program Change message (including MIDI Program Number) will be transmitted to the Slave. If the Slave has the MIDI capabilities to receive this message, its own voice will be changed according to the MIDI Program Number it has received. Conversely, when the YPP-55 is the Slave, it can receive the message and will automatically select its voice according to the MIDI Program Number from the Master.

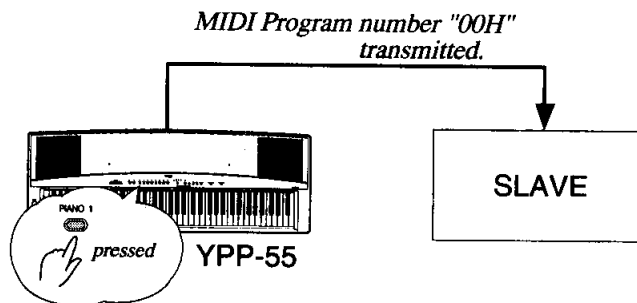

The following chart shows the relation between YPP-55 voices and MIDI Program Numbers.

MIDI Program Number	YPP-55 Voice/Voice Select Button
00H	PIANO 1
01H	PIANO 2
02H	E. PIANO
03H	HARPSICHORD
04H	VIBES
05H	STRINGS
06H	CHOIR
07H	PIPE ORGAN

\* This relation applies to both transmission and reception. MIDI Program Numbers other than those in the chart cannot be transmitted or received. (H: Hexadecimal number; used in describing MIDI data)

### Cancelling Program Change Message

Program Change message is automatically available when the YPP-55 is turned on. Though it is a very useful feature, you may sometimes run into a situation where you wish to cancel it. To cancel Program Change message, while holding down the MIDI/TRANPOSE button, press the Voice Select button PIANO 2. To reactivate this message, repeat the same procedure.

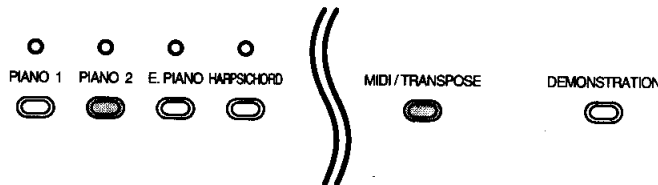

## 2) Control Change Message

Control Change message deals with various aspects of the played sound. For instance, when you're using the YPP-55 as a Master, and you depress the foot switch, a Control Change message (including MIDI Control Number and a Damper value) will be transmitted, and the Slave's sound will also be sustained (unless it cannot receive the message). If the YPP-55 is the Slave, it will receive Control Change messages from the Master. The YPP-55, as a Master, can transmit only Damper information (MIDI Control Number 64 in the following chart). As a Slave, however, it can receive a lot more information, as shown in the chart below:

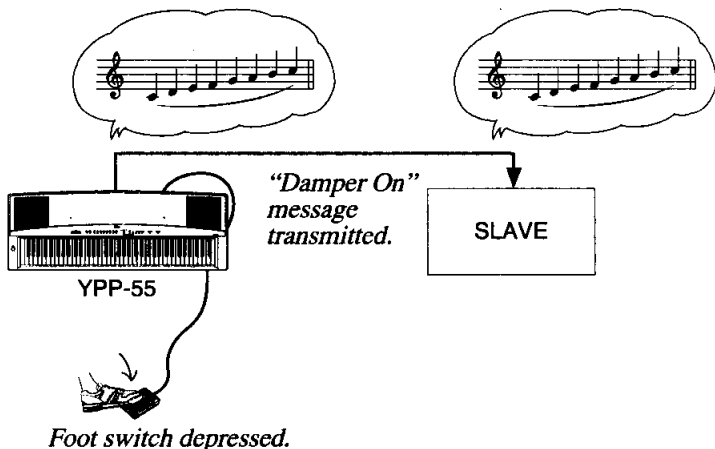
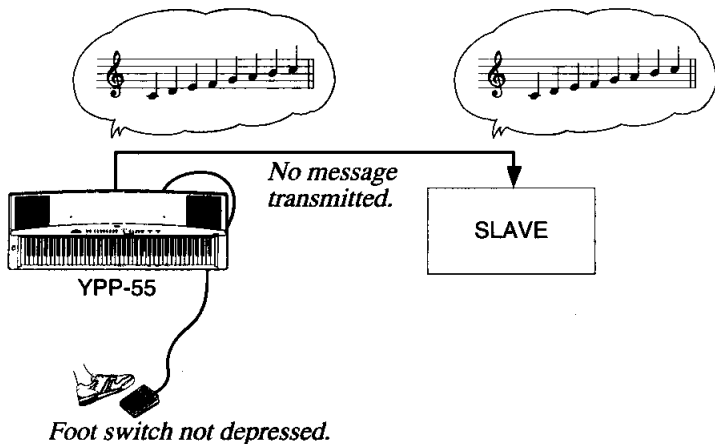

## YPP-55 Control Change Message Reception Capabilities

MIDI Control Number	Name	Value
7	Volume (*1)	0-127
11	Expression (*1)	0-127
64	Damper	0: Off, 1-127: On (Variable)
122	Local On/Off (*2)	0: Off, 1-127: On
123	All Notes Off (*3)	0
124	Omni Off (*4)	0
125	Omni On (*4)	0

- (\*1) **Volume/Expression:** The volume of the YPP-55 will be adjusted internally regardless of its panel setting, according to the Control Change message it receives. For instance, if the YPP-55 receives a "0" value message for volume/expression, it will not produce a sound even if its own VOLUME slider is set to the MAX position.
- (\*2) **Local On/Off:** Upon reception of a Local Off message, the YPP-55's keyboard will be separated from its internal sound module. See notes on page 18 for details.
- (\*3) **All Notes Off:** As soon as the YPP-55 receives this instruction, all of its notes sounding at that time will be muted.
- (\*4) **Omni Off/On:** See the following section, "MIDI Channels", for details.

## Cancelling Control Change Message

Normally, Control Change message is automatically available when the YPP-55 is turned on. But you may wish to create a situation where, for example, the Slave YPP-55 sounds are not sustained in tandem with the Master sounds. To cancel the Control Change message, while holding down the MIDI/TRANSPOSE button, press the Voice Select button E. PIANO. To reactivate this message, repeat the same procedure.

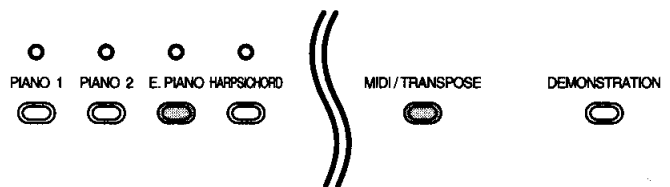

The above-described Note On, Program Change, and Control Change messages are known as

MIDI channel information. That is, these messages are communicated through MIDI channels. Please read the next section to find out more about these channels.

### C. MIDI Channels

There are 16 MIDI channels (1-16). Unless MIDI instruments are set to the same MIDI channel, they cannot communicate MIDI channel information (Note On, Program Change, Control Change, etc.), even if the cables are connected properly. MIDI channels can be compared to television channels, i.e. information from several TV stations is transmitted through the air, so to receive the desired program, you have to select one channel on your TV set.

When the YPP-55 is turned on, both its transmitting and receiving MIDI channels are set to 1. If required, these channels can be reset.

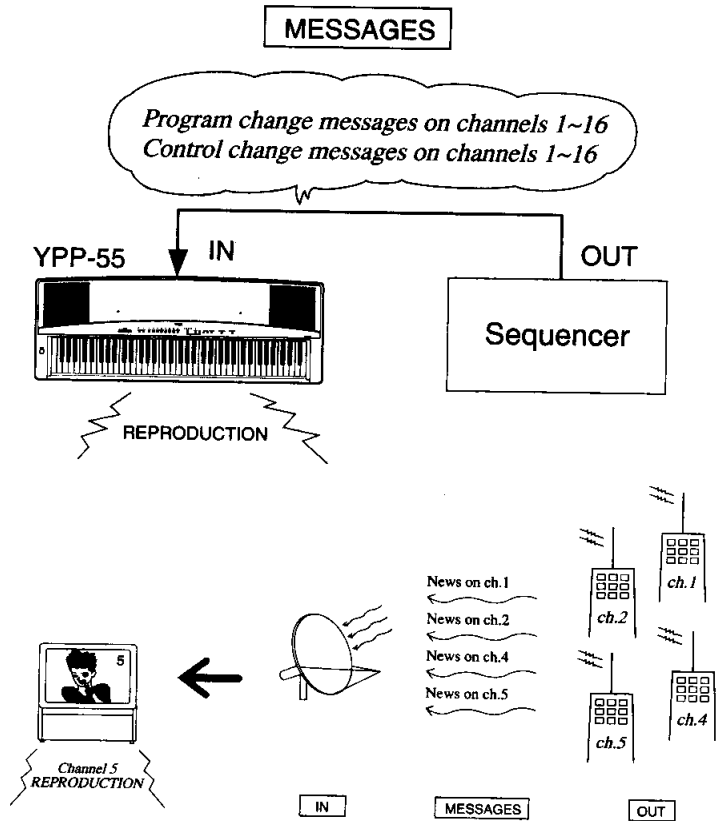

#### 1) Setting a MIDI Transmitting Channel

While holding down the MIDI/TRANSCOPE button, press one of 16 keys from C1 to D<sup>♯</sup> 2 according to the table below.

Key	C <sub>1</sub>	C <sup>♯</sup> <sub>1</sub>	D <sub>1</sub>	D <sup>♯</sup> <sub>1</sub>	E <sub>1</sub>	F <sub>1</sub>	F <sup>♯</sup> <sub>1</sub>	G <sub>1</sub>	G <sup>♯</sup> <sub>1</sub>	A <sub>1</sub>	A <sup>♯</sup> <sub>1</sub>	B <sub>1</sub>	C <sub>2</sub>	C <sup>♯</sup> <sub>2</sub>	D <sub>2</sub>	D <sup>♯</sup> <sub>2</sub>
Channel	1	2	3	4	5	6	7	8	9	10	11	12	13	14	15	16

#### 2) Setting a MIDI Receiving Channel

While holding down the MIDI/TRANSCOPE button, press one of 16 keys from C<sub>3</sub> to D<sup>♯</sup> 4 according to the table below.

Key	C <sub>3</sub>	C <sup>♯</sup> <sub>3</sub>	D <sub>3</sub>	D <sup>♯</sup> <sub>3</sub>	E <sub>3</sub>	F <sub>3</sub>	F <sup>♯</sup> <sub>3</sub>	G <sub>3</sub>	G <sup>♯</sup> <sub>3</sub>	A <sub>3</sub>	A <sup>♯</sup> <sub>3</sub>	B <sub>3</sub>	C <sub>4</sub>	C <sup>♯</sup> <sub>4</sub>	D <sub>4</sub>	D <sup>♯</sup> <sub>4</sub>
Channel	1	2	3	4	5	6	7	8	9	10	11	12	13	14	15	16

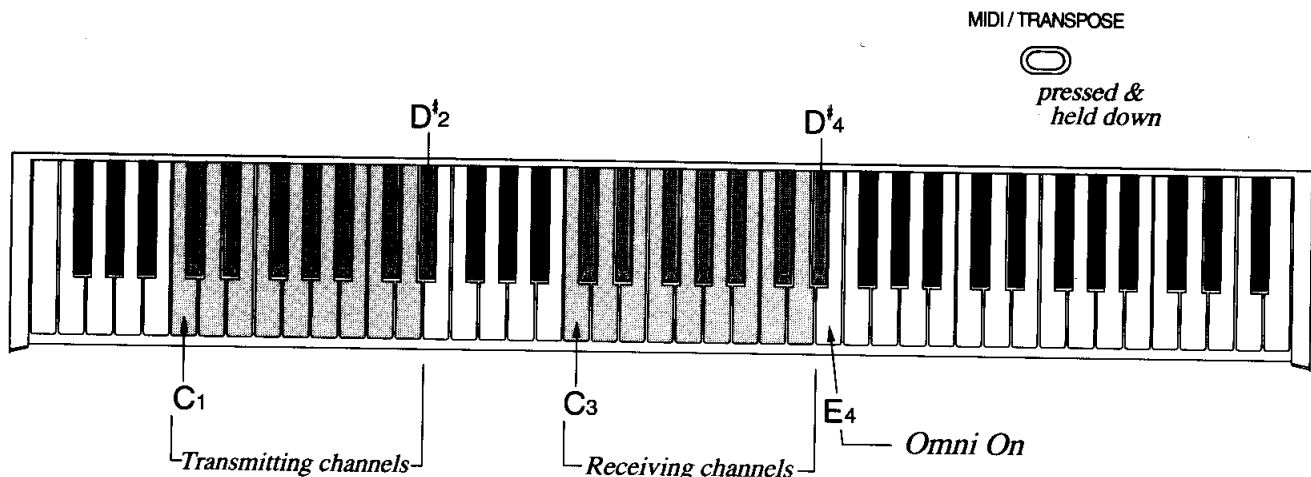



### 3) Omni On Mode

If required, the YPP-55 can be set to receive information on all MIDI channels (1-16). This mode is called "Omni On". To set the YPP-55 to this mode, while holding down the MIDI/TRANSPOSE button, press the E4 key. To get out of this mode, either select a specific receiving channel, or turn off the YPP-55, then turn it on again after a few seconds.

*Note: If you have several Slaves, all set to OMNI Mode, they will all receive the same instructions, and therefore play the same music. To achieve individual control of the Slaves, that is, to get each one to respond to different instructions and play its own part in an ensemble, you must set the Slaves' MIDI receiving channels individually. When a specific channel is selected, it means the instrument is in "Omni Off" mode.*

## D. Applications

The following four examples show how several of the YPP-55's MIDI functions can be applied in specific setups. In order to make best use of MIDI, it is important to determine which instruments are most effective as Masters or as Slaves. This will depend on the individual situation. Consulting the MIDI implementation chart of each instrument in your setup will help you to decide in each case. If one instrument has more transmission capabilities than the other(s), it will generally be better suited as the Master. Conversely, instruments with more recognition capabilities will be better Slaves.

### Example 1: Using the YPP-55 with another keyboard or sound module

Beginners using MIDI should first make a Hand-Shaking connection between the two MIDI keyboards. After matching the transmitting and receiving MIDI channels, you can use either instrument as Master or Slave. Whichever keyboard you play, you will hear the sounds of both instruments. In addition, the Slave will duplicate the Master's sustain, touch response, etc., as long as it is equipped to receive MIDI messages such as Program Change, Control Change, and so on.

- \* Practicing with a Hand-Shaking connection is a good way to learn which instrument will make the better Master or Slave in a One-Way connection.
- \* If you are connecting the YPP-55 to a MIDI sound module, the latter is best used as a Slave in a One-Way connection.

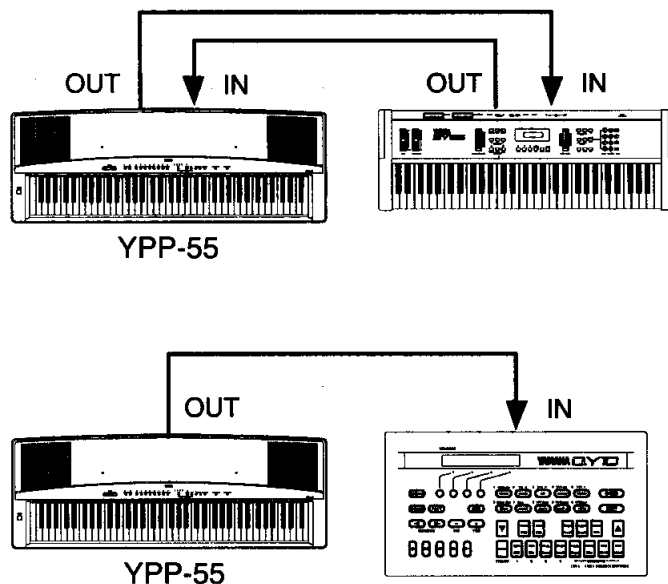

## Example 2: Using the YPP-55 with a drum machine

If you have a MIDI-compatible rhythm/drum machine, use it as a Slave of the YPP-55. After matching MIDI channels, play the YPP-55 keyboard. Now you can have various percussion sounds at your fingertips. Playing a key on the YPP-55 will transmit a specific MIDI Note Number to the drum machine, which reproduces the percussion sound corresponding to it.

Here's another idea: If your drum machine includes a melody instrument such as bass or vibraphone, you can access this sound from the YPP-55. First, look up the MIDI receiving channel assigned for controlling the sound. Then, set both instruments to this channel. You can now play the drum machine's melody instrument sound from the YPP-55. If you wish, you can accompany your performance with a rhythmic pattern (start/stopped locally on the drum machine). Your entire performance for the melodic instrument can be input into the drum machine as sequence data.

## Example 3: Using the YPP-55 with a sequencer (and other keyboards)

Knowing how to use the YPP-55 effectively with a sequencer makes you a MIDI pro!

After you've recorded all the parts of your performance on the sequencer, you'll want to play back your ensemble, with each part matched (via MIDI channels) to the appropriate instrument or sound module. Say you've recorded a two-part ensemble, cello and flute, on MIDI channels 1 and 2, each channel matched to a separate instrument or sound module in your MIDI system (instruments A and B in the Diagram below). When you play back the ensemble, you may wish to experiment with the sounds. Here's one thing you can try: put the YPP-55 (one of the Slaves in your setup) in OMNI ON mode, and select the voice you wish, say PIANO 1. Thus, the YPP-55 will receive performance data on both MIDI channels 1 and 2, and therefore will play back both parts in PIANO 1 voice, as a complement to the cello and flute sounds from instruments A and B.

\* Another use of OMNI ON mode is for checking the contents of an untitled performance data disk whose MIDI channels are unspecified. After loading the data into the sequencer, transmit it from the sequencer to the YPP-55 in OMNI ON mode. Regardless of the MIDI channels to which the data was assigned, the YPP-55 in OMNI ON mode will play it back.

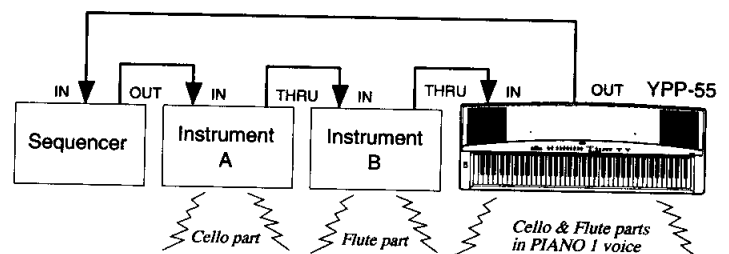
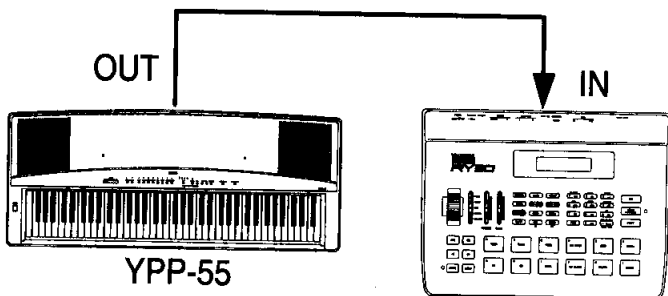

If you set up a Hand-Shaking connection between the YPP-55 and the sequencer, there are two things to be noted:

- \* If the sequencer is set to transmit the same MIDI information as received at its MIDI IN jack (This is called "Echo On", "Soft Thru On", etc., depending on the make), set the YPP-55 to "Local Control Off" (\*1). If you fail to do this, pressing a single key will sound twice as many notes as in normal play. As a result, it will reduce the polyphonic notes you can play at a time.
- \* Conversely, when the sequencer is set to "Echo Off" ("Soft Thru Off", etc.), you cannot play directly from the keyboard with the YPP-55 in Local Control Off, because the sequencer doesn't retransmit any received MIDI data. In this case, you have to set the YPP-55 to Local Control On, which enables you to control the sound module from either the keyboard or the sequencer.

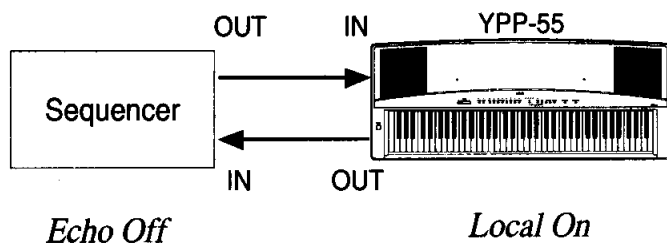
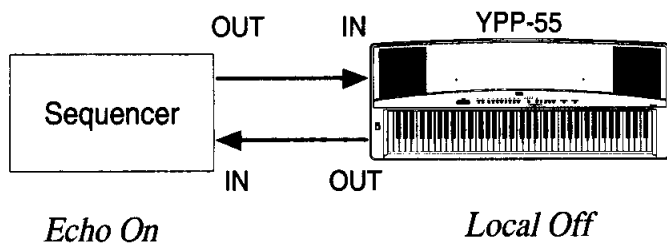

### (\*1)Note: Local Control On/Off:

Normally, the YPP-55's keyboard is connected to its internal sound module, which means that when you play, a sound is output from the instrument, and when you select a different voice, the sound changes. This state is called "Local Control On". However, if desired, the YPP-55 can be set to "Local Control Off". In this state, the keyboard is disconnected from the sound module, which means that if you play something, a sound will not be produced from the instrument itself, but your performance can be transmitted via MIDI to an external instrument.

### Setting to Local Control Off

While holding down the MIDI/TRANSCOPE button, press Voice Select button PIANO 1. To return the YPP-55 to Local Control On, repeat the same procedure.

One of the most exciting features of the YPP-55 is that it is capable of playing all of its eight voices at the same time. This feature is called **Multi-timbre**, and is most useful when using the YPP-55 as a Slave from a sequencer.

### What is Multi-timbre?

The YPP-55 has two play modes: Normal and Multi-timbre. When the instrument is turned on, it is always in Normal mode, that is, you play a single voice on the keyboard. When in Multi-timbre mode, however, the YPP-55 will act as ten independent sound modules, with all 8 preset voices available for use in an ensemble performance.

### Entering Multi-timbre mode

While holding down the MIDI/TRANSCOPE button, press the HARPSICHORD Voice Select button. To exit from Multi-timbre mode, repeat the same operation once again.

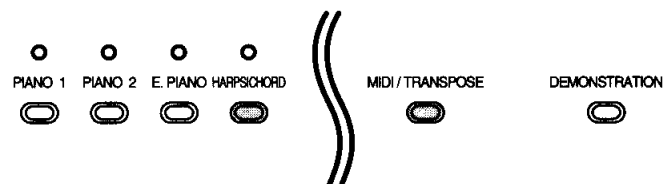

Now, try using the YPP-55 in Multi-timbre mode with a sequencer(\*).

\* To best use the YPP-55 in Multi-timbre mode, you will need a Master device which can control other devices with different MIDI channels at the same time. This could be a sequencer, MIDI-equipped personal computer, or MIDI master keyboard.

The following diagram relates to a Hand-Shaking connection between the YPP-55 and a sequencer. Try going quickly through the following steps, to become familiar with the use of Multi-timbre mode. The object is to record an ensemble performance of several parts onto the sequencer, then play it back with each part sounding in a different YPP-55 voice.

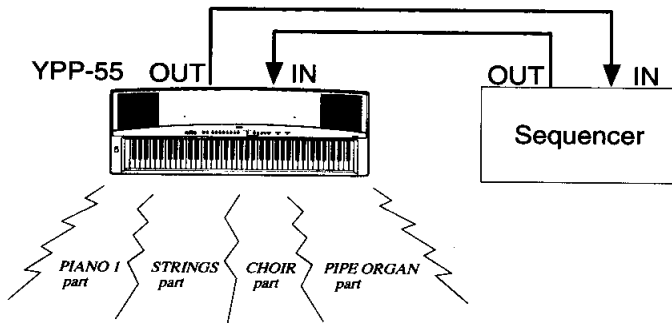

**Step 1:** Set the YPP-55 in Multi-timbre mode.

**Step 2:** Ensure the YPP-55 is set to Local Control On and the sequencer to Echo Off, or the YPP-55 to Local Control Off and the sequencer to Echo On.

Remember the notes on page 18.

**Step 3:** Select a MIDI transmitting channel from 1-10(\*) on the YPP-55, then select the voice you desire.

\* In Multi-timbre mode, the YPP-55's sound module can receive MIDI messages on channels 1-10. MIDI messages on channels 11-16 cannot control the YPP-55's sound module. Also note when you enter Multi-timbre mode, if you do not select a desired voice, the YPP-55 will automatically select one as shown in the following chart:

Channel 1:	PIANO 1
Channel 2:	PIANO 2
Channel 3:	E. PIANO
Channel 4:	HARPSICHORD
Channel 5:	VIBES
Channel 6:	STRINGS
Channel 7:	CHOIR
Channel 8:	PIPE ORGAN
Channel 9:	PIANO 1
Channel 10:	PIANO 2

**Step 4:** Play one of the ensemble parts on the keyboard, pedalling as needed, and record it onto one of the tracks of the sequencer. You may, of course, change voices during play.

**Step 5:** Repeat Steps 3 and 4 as needed. In each case, select the appropriate MIDI channel (according to the voice desired for that part) before Step 3, and in Step 4, record onto a new track or overdub onto previously recorded tracks.

**Step 6:** Play back the completed ensemble performance from the sequencer. You will hear the different voices, corresponding to the different parts of the ensemble, played out simultaneously.

# MAINTENANCE

- Every once in a while, wipe the cabinet clean with a soft cloth slightly moistened with a diluted soap solution, then wipe again with a dry cloth. Don't use chemically treated cloths or other chemicals like oil, solvents or insecticides.
- Do not expose the unit to direct sunlight, moisture or extremes in temperature. This includes not placing the unit on top of amplifiers, receivers or other heat sources, especially those with temperatures higher than 60°C (140°F).
- Place the unit on a firm, level, vibration-free surface. Do not set anything on top of it.
- Keep the unit away from sources of strong magnetism, and from highly dusty or humid areas.
- Do not remove the unit's cover, as this can cause electric shock. All repairs should be referred to a YAMAHA service center or qualified YAMAHA personnel.

**YAMAHA IS NOT RESPONSIBLE FOR DAMAGE CAUSED BY IMPROPER USE.**

# TROUBLESHOOTING

Many "problems" can be solved quite easily. Before calling your YAMAHA dealer, please refer to the following table.

<b>PROBLEM</b>	<b>POSSIBLE SOLUTION</b>
<ul style="list-style-type: none"><li>• Power does not come on.</li><li>• Volume is too low.</li><li>• Sounds cannot be sustained.</li></ul>	<ul style="list-style-type: none"><li>• Make sure the power plug is firmly connected to the AC current.</li><li>• Adjust the VOLUME slide control.</li><li>• Make sure the foot switch is firmly connected to the DAMPER jack.</li><li>• More than 16 notes (32 notes when using PIANO 2 and HARPSICHORD) may be playing at a time. Lessen the notes you play.</li></ul>
<ul style="list-style-type: none"><li>• No sound.</li></ul>	<ul style="list-style-type: none"><li>• Remove headphones if plugged in.</li><li>• Reset the YPP-55 to "Local Control On" if not in this mode.</li></ul>
<ul style="list-style-type: none"><li>• Distorted sound.</li><li>• Song cannot be recorded.</li></ul>	<ul style="list-style-type: none"><li>• Lower the volume.</li><li>• Memory capacity has been exceeded. Clear other song memory.</li></ul>
<ul style="list-style-type: none"><li>• MIDI information is not being transmitted or received.</li></ul>	<ul style="list-style-type: none"><li>• Match MIDI channels of transmitting and receiving instruments.</li></ul>

# SPECIFICATIONS

<b>Keyboard</b>	76 keys (E0-G6) with touch sensitivity
<b>Voice Technology</b>	AWM
<b>Polyphony</b>	32(PIANO 2, HARPSICHORD) 16(PIANO 1, E. PIANO, VIBES, STRINGS, CHOIR, PIPE ORGAN)
<b>Voices</b>	PIANO 1, PIANO 2, E. PIANO, HARPSICHORD, VIBES, STRINGS, CHOIR, PIPE ORGAN
<b>Effects</b>	DAMPER (foot) switch, REVERB and ENSEMBLE buttons
<b>Performance Memory</b>	SONG button, RECORD button, PLAY button
<b>Metronome</b>	METRONOME button, TEMPO buttons
<b>Controls</b>	POWER switch, VOLUME slider, MIDI/TRANSDPOSE button, DEMONSTRATION button
<b>Jacks</b>	MIDI (IN, OUT), DAMPER, AUX. OUT L/L+R, R HEADPHONES 1, 2
<b>Amplifier</b>	7.0 W x 2
<b>Speakers</b>	12.0 cm (6Ω) x 2
<b>Dimensions</b>	1,203 mm x 774 mm x 433 mm (WxHxD, including the Keyboard stand LW-11) 1,203 mm x 147 mm x 433mm (W x H x D, not including the Keyboard stand LW-11)
<b>Weight</b>	22.5 kg (including the keyboard stand LW-11) 14 kg (not including the keyboard stand LW-11)
<b>Accessories</b>	Music Stand, Foot Switch FC5, Dust Cover

- \* Depending on the distribution system and the regulations in your country or area, the Keyboard stand LW-11 may or may not be included with the product. If it is not included, it can be purchased separately.
- \* YAMAHA reserves the right to make design and specification changes in the interests of product improvement without prior notice.

Function	...	Transmitted	Recognized	Remarks
Basic Channel	Default Changed	1 1-16	1 1-16	
Mode	Default Messages	3 x	3 OMNI ON/OFF x	
Note Number :	True Voice	28-103 * * * * *	21-108 21-108	
Velocity	Note On Note Off	o 9nH, v=1-127 x 9nH, v=0	o v=1-127 x	
After Touch	Key's Ch's	x x	x x	
Pitch Bender		x	x	
Control Change	7 11 64	x x o	o o o	VOLUME EXPRESSION DAMPER
Program Change :	True #	o 0-7 * * * * *	o 0-7 0-7	
System Exclusive		o	o	
System Common	: Song Pos : Song Sel : Tune	x x x	x x x	
System Real Time	: Clock : Commands	x x	x x	
Aux Messages	: Local ON/OFF : All Notes OFF : Active Sense : Reset	x x o x	o o (122-125) o x	
Notes :				

Mode 1: OMNI ON, POLY    MODE 2: OMNI ON, MONO  
 Mode 3: OMNI OFF, POLY    Mode 4: OMNI OFF, MONO

o: YES  
 x: NO

## FCC INFORMATION (U.S.A)

**1. IMPORTANT NOTICE: DO NOT MODIFY THIS UNIT!**

This product, when installed as indicated in the instructions contained in this manual, meets FCC requirements. Modifications not expressly approved by Yamaha may void your authority, granted by the FCC, to use the product.

**2. IMPORTANT:** When connecting this product to accessories and/or another product use only high quality shielded cables. Cable/s supplied with this product **MUST** be used. Follow all installation instructions. Failure to follow instructions could void your FCC authorization to use this product in the USA.

**3. NOTE:** This product has been tested and found to comply with the requirements listed in FCC Regulations, Part 15 for Class "B" digital devices. Compliance with these requirements provides a reasonable level of assurance that your use of this product in a residential environment will not result in harmful interference with other electronic devices. This equipment generates/uses radio frequencies and, if not installed and used according to the instructions found in the users manual, may cause interference harmful to the operation of other electronic devices. Compliance with FCC regulations does not guarantee that interference will not occur in all installations. If this product is found to be the source of interference, which can be determined by turning the unit "OFF" and "ON", please try to eliminate the problem by using one of the following measures:

Relocate either this product or the device that is being affected by the interference.

Utilize power outlets that are on different branch (circuit breaker or fuse) circuits or install AC line filter/s.

In the case of radio or TV interference, relocate/reorient the antenna. If the antenna lead-in is 300 ohm ribbon lead, change the lead-in to co-axial type cable.

If these corrective measures do not produce satisfactory results, please contact the local retailer authorized to distribute this type of product. If you can not locate the appropriate retailer, please contact Yamaha Corporation of America, Electronic Service Division, 6600 Orangethorpe Ave, Buena Park, CA 90620.

The above statements apply **ONLY** to those products distributed by Yamaha Corporation of America or its subsidiaries.

\* This applies only to products distributed by YAMAHA CORPORATION OF AMERICA.



Wichtiger Hinweis für die Benutzung in der Bundesrepublik Deutschland.

### Bescheinigung des Importeurs

Hiermit wird bescheinigt, daß der/die/das  
*Personal Electronic Piano Typ: YPP-55*

(Gerät, Typ, Bezeichnung)

in Übereinstimmung mit den Bestimmungen der  
VERFÜGUNG 1046/84

(Amtsblattverfügung)

funk-entstört ist.

Der Deutschen Bundespost wurde das Inverkehrbringen  
dieses Gerätes angezeigt und die Berechtigung zur Überprüfung  
der Serie auf Einhaltung der Bestimmungen eingeräumt.

**Yamaha Europa GmbH**

Name des Importeurs

\* Dies bezieht sich nur auf die von der Yamaha Europa GmbH vertriebenen Produkte.

### IMPORTANT NOTICE FOR THE UNITED KINGDOM

#### Connecting the Plug and Cord

IMPORTANT. the wires in this mains lead are coloured in accordance with the following code:

BLUE : NEUTRAL  
BROWN : LIVE

As the colours of the wires in the mains lead of this apparatus may not correspond with the coloured markings identifying the terminals in your plug, proceed as follows:

The wire which is coloured BLUE must be connected to the terminal which is marked with the letter N or coloured BLACK.

The wire which is coloured BROWN must be connected to the terminal which is marked with the letter L or coloured RED.

Making sure that neither core is connected to the earth terminal of the three pin plug.

\* This applies only to products distributed by Yamaha-Kemble Music (U.K.) LTD.

### CANADA

THIS DIGITAL APPARATUS DOES NOT EXCEED THE "CLASS B" LIMITS FOR RADIO NOISE EMISSIONS FROM DIGITAL APPARATUS SET OUT IN THE RADIO INTERFERENCE REGULATION OF THE CANADIAN DEPARTMENT OF COMMUNICATIONS.

LE PRESENT APPAREIL NUMERIQUE N'EMET PAS DE BRUITS RADIOELECTRIQUES DEPASSANT LES LIMITES APPLICABLES AUX APPAREILS NUMERIQUES DE LA "CLASS B" PRESCRITES DANS LE REGLEMENT SUR LE BROUILLAGE RADIOELECTRIQUE ÉDICTÉ PAR LE MINISTÈRE DES COMMUNICATIONS DU CANADA.

\* This applies only to products distributed by Yamaha Canada Music Ltd.  
\* Ceci ne s'applique qu'aux produits distribués par Yamaha Canada Musique Ltée.

Dette apparat overholder det gældende EF-direktiv vedrørende radiostøj.

Cet appareil est conforme aux prescriptions de la directive communautaire 87/308/CEE.

Diese Geräte entsprechen der EG-Richtlinie 82/499/EWG und/oder 87/308/EWG.

This product complies with the radio frequency interference requirements of the Council Directive 82/499/EEC and/or 87/308/EEC.

Questo apparecchio è conforme al D.M.13 aprile 1989 (Direttiva CEE/87/308) sulla soppressione dei radiodisturbi.

Este producto está de acuerdo con los requisitos sobre interferencias de radio frecuencia fijados por el Consejo Directivo 87/308/CEE.

**YAMAHA CORPORATION**

**NAME PLATE LOCATION:** The nameplate is located on the bottom panel. The Model, Serial Number, Power requirements, etc., are indicated on this plate. You should note the model, serial number and the date of purchase in the spaces provided below and retain this manual as a permanent record of your purchase.

Model \_\_\_\_\_

Serial No. \_\_\_\_\_

Purchase Date \_\_\_\_\_

**LAGES DES TYPENSCHILDS:** Das Typenschild befindet sich am Geräteboden. Modellbezeichnung, Seriennummer, Betriebsstrom etc, sind auf dem Typenschild angegeben. Tragen Sie Modellbezeichnung, Seriennummer und Kaufdatum in die unten vorhandenen Felder ein und bewahren Sie dieses Handbuch als permanenten Kaufbeleg auf.

Modell \_\_\_\_\_

Seriennummer \_\_\_\_\_

Kaufdatum \_\_\_\_\_

**EMPLACEMENT DE LA PLAQUE SIGNALÉTIQUE:** La plaque signalétique se trouve sur le panneau inférieur. Le modèle, le numéro de série, l'alimentation requise et autres paramètres sont indiqués sur cette plaque. Inscrire le modèle, le numéro de série et la date de l'achat dans l'espace prévu ci-dessous et conserver le mode d'emploi à titre d'enregistrement permanent de l'achat.

Modèle \_\_\_\_\_

N° de série \_\_\_\_\_

Date de l'achat \_\_\_\_\_

**UBICACION DE LA PLACA DE CARACTERISTICAS:** La placa de características está situada en el panel inferior. En esta placa se indican el modelo, el número de serie, la tensión de alimentación, etc. Anote el modelo, el número de serie, y la fecha de adquisición en los espacios ofrecidos a continuación, y guarde este manual como registro permanente de su adquisición.

Modelo \_\_\_\_\_

N.º de serie \_\_\_\_\_

Fecha de adquisición \_\_\_\_\_

**YAMAHA**