

**USER'S GUIDE
BEDIENUNGSANLEITUNG
MODE D' EMPLOI**

CVS-10

For Electones
COMBINATION VOICE EXPANDER
Für Electones
COMBINATION VOICE EXPANDER
Pour Electones
EXPANSEUR DE VOIX COMBINEES

YAMAHA

 Thank you for purchasing the YAMAHA Combination Voice Expander CVS-10.

The CVS-10 gives you new organ sounds for each keyboard of your Electone. It comes preset with 16 organ voices each for the upper and lower keyboards, plus 8 organ voices for the pedal keyboard, all of which can be edited to create the desired sound. To get optimum satisfaction from your CVS-10, please read through this User's Guide carefully.

 Herzlichen Glückwunsch zum Kauf des YAMAHA Combination Voice Expander CVS-10.

Der CVS-10 bietet Ihnen neue Orgelsounds für jede Tastatur Ihres Electones. Er wird mit je 16 ab Werk programmierten Orgelvoices für oberes und unteres Manual sowie 8 Orgelvoices für das Fußregister geliefert, die alle bearbeitet werden können, um genau den gewünschten Sound zu erzeugen. Um die Möglichkeiten des CVS-10 voll auszunutzen, lesen Sie diese Bedienungsanleitung bitte gründlich durch.

 Merci d'avoir porté votre choix sur l'expandeur de voix combinées CVS-10 de YAMAHA.

Le CVS-10 vous offre de nouvelles sonorités d'orgue pour chaque clavier de votre Electone. L'appareil contient 16 voix d'orgue pré-réglées pour le clavier supérieur et le clavier inférieur et 8 voix d'orgue pour le clavier à pédales. Toutes peuvent être montées pour créer le son souhaité. Pour tirer le meilleur parti de votre CVS-10, veuillez lire attentivement ce mode d'emploi.

CONTENTS

INTRODUCTION

Handling Precautions	2
Connection Procedures	3
Description of Parts	4

DESCRIPTION OF FUNCTIONS

● Before You Begin	5
● Choosing a Voice	6
● Editing a Voice	8
● Adding an Effect	
TREMOLLO/CHORUS	10
REVERB	13

● Using the Registrations	
Memorizing a Registration	14
Recalling a Registration	16
● Other Types of Control	
PITCH	17
TRANSPPOSITION	18
MIDI CONTROL	19
Changing the Attack Mode	21
FOR YOUR REFERENCE	
● Troubleshooting	22
● Specifications	23
● MIDI Implementation Chart	24
● System Exclusive Messages	25

INHALTSVERZEICHNIS

EINLEITUNG

Vorsichtsmaßnahmen zum Umgang	2
Anschlußverfahren	3
Beschreibung der Bedienungselemente	4

BESCHREIBUNG DER FUNKTIONEN

● Bevor Sie beginnen	5
● Wählen einer Voice	6
● Bearbeiten einer Voice	8
● Hinzufügen eines Effekts	
TREMOLLO/CHORUS	10
REVERB	13

● Einsatz der Registrierungen	
Speichern einer Registrierung	14
Abruf einer Registrierung	16
● Weitere Steuerfunktionen	
PITCH	17
TRANSPPOSITION	18
MIDI CONTROL	19
Ändern des Attack-Modus	21
ZU IHRER INFORMATION	
● Fehlersuche	22
● Technische Daten	23
● MIDI Implementation Chart	24
● System-Exklusivmeldungen	25

TABLE DES MATIERES

INTRODUCTION

Précautions d'utilisation	2
Démarches des connexions	3
Description des commandes	4

DESCRIPTION DES FONCTIONS

● Préparatifs	5
● Sélection de voix	6
● Montage d'une voix	8
● Ajout d'effet	
TREMOLLO/CHOEUR	10
REVERBERATION	13

● Utilisation des registres	
Mémorisation d'un registre	14
Rappel d'un registre	16
● Autres types de réglages	
HAUTEUR DU SON	7
TRANSPPOSITION	18
CONTROLE MIDI	19
Changement du mode d'attaque	21
A TITRE DE REFERENCE PERSONNELLE	
● Guide de dépannage	22
● Spécifications	23
● Tableau d'implémentation MIDI	24
● Message Exclusifs du Systeme	25

INTRODUCTION

Handling Precautions

Power Supply

- Make sure to use only the YAMAHA power adapter PA-W10.

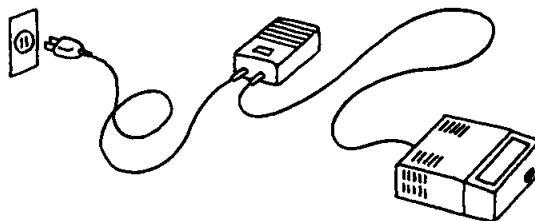

- In case of electrical storm probability, unplug the power cord from the electrical socket in advance.
- If you will not use the CVS-10 for a long period of time, unplug the power adapter from the electrical outlet.

Power Cord

- Be careful not to touch the power plug with wet hands; you may receive an electric shock.
- To prevent damage and short-circuiting of the cord wires, always hold the plug when unplugging the cord and never pull on the cord.

Connection

- Before connecting the CVS-10, make sure that the POWER switch of the Electone is turned OFF.
- Before transporting the CVS-10, make sure to disconnect its power cord and MIDI cables.

Handling

- Never remodel the CVS-10 nor disassemble its parts yourself. Such actions can cause serious damage to the CVS-10.
- Never subject the buttons and switches to unnecessary force.
- To prevent damage and short-circuiting of the cord wires, always hold the plug when unplugging the cord and never pull on the cord.
- If water accidentally enters the CVS-10, immediately turn OFF the POWER switch, unplug the power cord, and contact the Yamaha Music Dealer where you purchased this unit.

Choosing an Installation Site

- Avoid places exposed to direct sunlight.
- Avoid places exposed to excessive moisture, dust, and excessively low temperatures.

Cleaning the Outer Case

- Clean the outer case by wiping it with a soft, dry cloth.
- Never use thinner, benzine, chemically harsh solvents nor chemically-treated cloths.
- If the case is particularly dirty, moisten a soft, clean cloth in a mild detergent diluted with water, wring the cloth out well, then wipe off the soiled areas. Next, wipe the unit again with a dry cloth.

If the CVS-10 Operates Abnormally

- If the CVS-10 produces an abnormal odor or smoke, immediately unplug the power cord and contact the Yamaha Music Dealer where you purchased this unit.

Connection Procedures

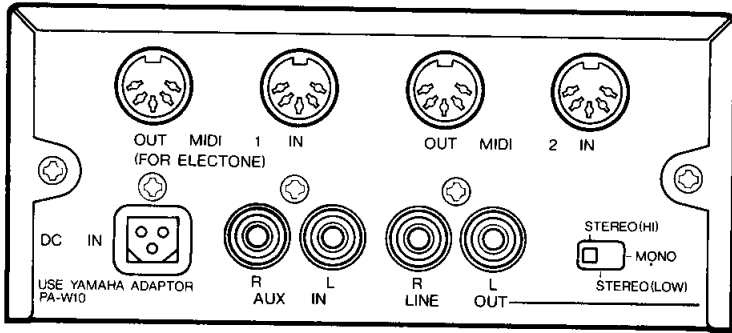

Connecting the MIDI Cables

*Set to STEREO (HI).

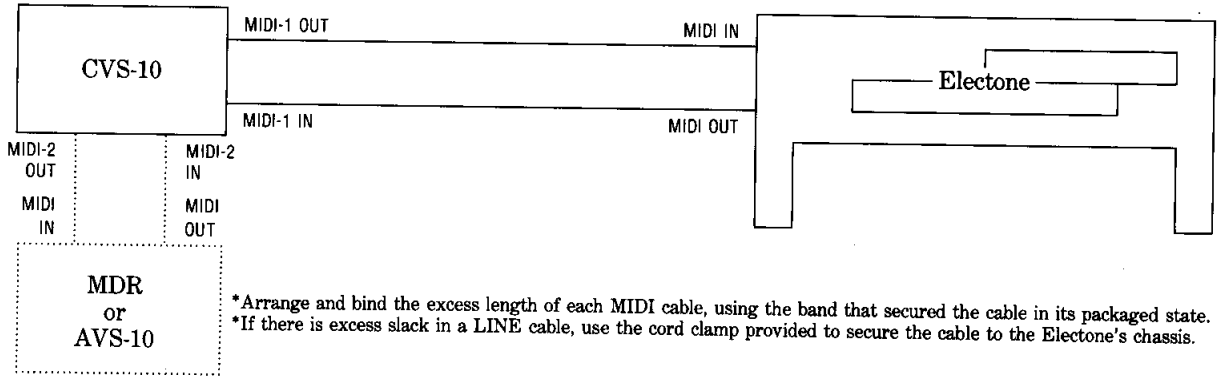

*Arrange and bind the excess length of each MIDI cable, using the band that secured the cable in its packaged state.
*If there is excess slack in a LINE cable, use the cord clamp provided to secure the cable to the Electone's chassis.

Connecting the LINE Cables

■ To connect CVS-10 to HS-8/7/6:

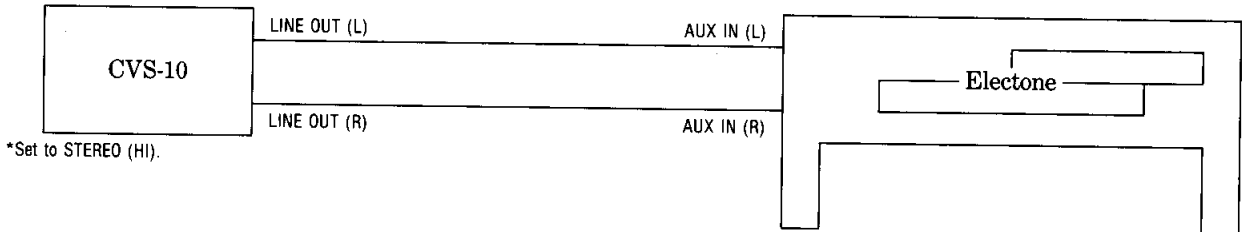

*Set to STEREO (HI).

■ To connect CVS-10 to HS-5/4 (or HX-1/3/5 or HE-8/6):

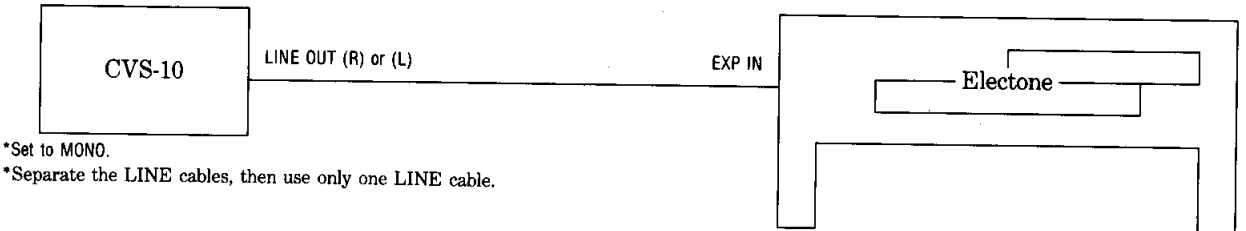

*Set to MONO.

*Separate the LINE cables, then use only one LINE cable.

■ To connect CVS-10 to a stereo system:

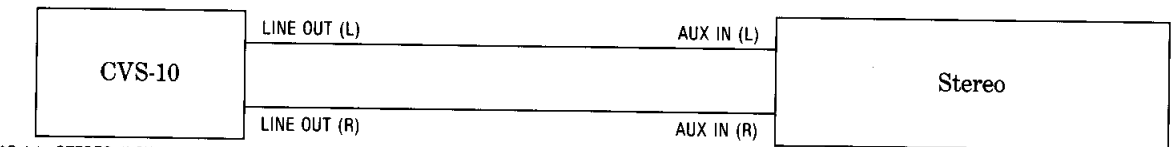

*Set to STEREO (LOW).

Description of Parts

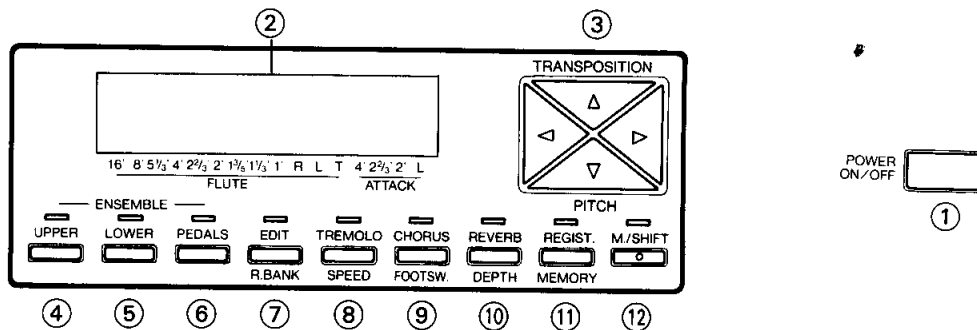

① **POWER:** Turns the power ON or OFF.

② **Display:** The status of various data is shown here.

③ ▷ ◁ Δ ▽: Used to move the cursor, change the data, activate a function, etc.

④ **ENSEMBLE-UPPER:** Turn this button ON to enable the voice selected at CVS-10 to be sounded from the Electone's upper keyboard. Turn it OFF to disable that voice.

⑤ **ENSEMBLE-LOWER:** Turn this button ON to enable the voice selected at CVS-10 to be sounded from the Electone's lower keyboard. Turn it OFF to disable that voice.

⑥ **ENSEMBLE-PEDALS:** Turn this button ON to enable the voice selected at CVS-10 to be sounded from the Electone's pedal keyboard. Turn it OFF to disable that voice.

⑦ **EDIT:** Press to edit the voice data of a User Voice.

⑦ **R. BANK:** To choose the Registration Bank No. for memorizing a registration, press this button while you hold down the M./SHIFT button.

⑧ **TREMOLO:** When the Tremolo/Chorus effect is ON, press this button to select Tremolo mode.

⑧ **SPEED:** To change the Tremolo Speed of TREMOLO/CHORUS, press this button while you hold down the M./SHIFT button.

⑨ **CHORUS:** When the Tremolo/Chorus effect is ON, press this button to select Chorus mode.

⑨ **FOOT SW.:** To enable/disable Foot Switch control of TREMOLO, press this button while you hold down the M./SHIFT button.

⑩ **REVERB:** Press to enable the Reverb effect.

⑩ **DEPTH:** To change the Reverb Depth, press this button while you hold down the M./SHIFT button.

⑪ **REGIST.:** Press to recall a memorized registration. This button is also used to change the MIDI Channel No. or to transmit Bulk data.

⑪ **MEMORY:** To memorize a registration, press this button while you hold down the M./SHIFT button.

⑫ **M./SHIFT:** To select the R.BANK, SPEED, FOOT SW., DEPTH, or MEMORY function at the bottom row, press the pertinent button while you hold down this button. This button is also used to change the Pitch or Transposition setting, change the Attack mode, etc.

DESCRIPTION OF FUNCTIONS

Before You Begin

Before choosing a voice, perform the operation below.

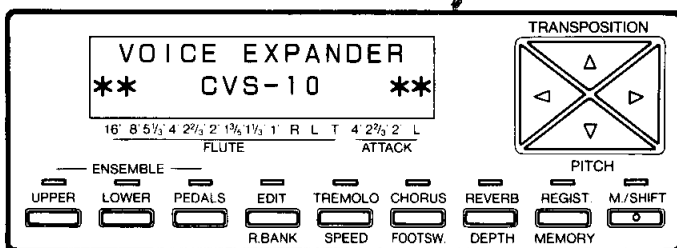

1. Turn ON the POWER switch.



After "VOICE EXPANDER CVS-10" appears on the display, "UPPER VOICE" is displayed.

[Power-ON Reset operation]

■ To return all the CVS-10 data to the originally preset values, turn OFF the POWER switch, then turn it back ON while you hold down the EDIT button. This operation resets all data to the preset values described below, clearing any data that you have previously set.

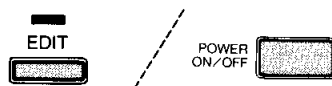

- **Voice No.:** GENERAL for all three keyboards
- **Voice Volume:** U/L: 24, P: 12
- **User Voices:** Identical to Preset voices
- **Tremolo/Chorus Speed:** 24
- **Foot Switch Control:** OFF
- **Reverb Depth:** 24
- **Regist. Bank:** 1
- **Registrations:** All GENERAL PRESETS from R. Banks 1 to 4
- **MIDI Receive Channel:** U:1, L:2, P:3
- **Attack Mode:** FIRST NEW KEY.

2. Decide how to set the ENSEMBLE buttons.

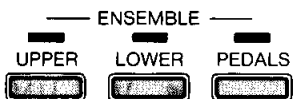

UPPER: ON/OFF status of the upper keyboard.

LOWER: ON/OFF status of the lower keyboard.

PEDALS: ON/OFF status of the pedal keyboard.

When an ENSEMBLE button is ON, the voice selected at CVS-10 can be sounded from the corresponding keyboard. When it is OFF, that voice will not be sounded.

Choosing a Voice

One voice can be chosen for each keyboard of the Electone.

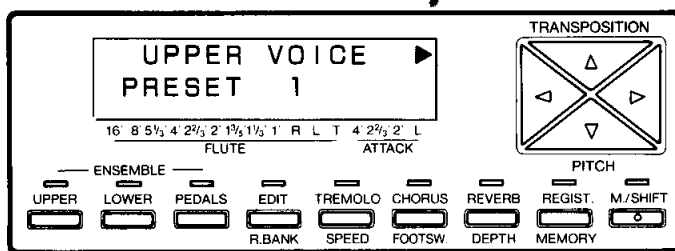

Choose the Voice

1. Press the \triangleright or \triangleleft button until the menu of the desired keyboard is displayed.

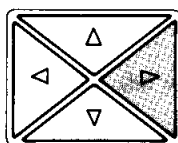
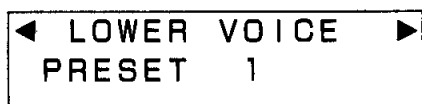

- \triangleright button: Shift to the next menu.
- \triangleleft button: Return to the previous menu.

2. Press the ∇ or \triangle button to choose the desired voice.

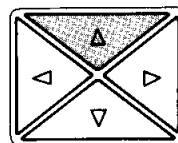
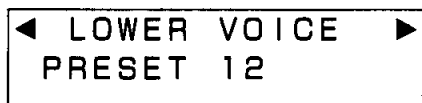

- ∇ button: Shift to the next Voice No.
- \triangle button: Return to the previous Voice No.

Available Range of Voice Nos.

UPPER VOICE	PRESET 1-16, USER 1-16
LOWER VOICE	PRESET 1-16, USER 1-16
PEDAL VOICE	PRESET 1-8, USER 1-8

The display will change in the sequence shown below:

Upper Keyboard voice

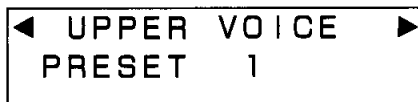

Lower Keyboard voice

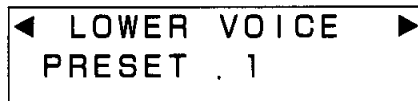

Pedal Keyboard voice



Volume setting

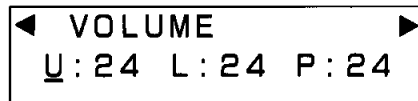

ON/OFF setting of TREMOLO/CHORUS (→page 10)

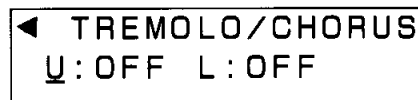

[Additional Information]

■ After creating your own unique voice by changing the voice data, the new voice can be stored as a User Voice. (→page 8)

Set its Volume

3. Press the \triangleright or \triangleleft button to display the **VOLUME** menu.

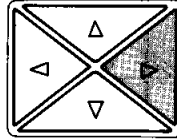
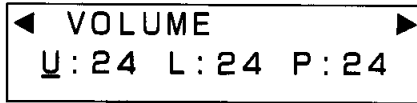

- \triangleright button: Shift to the next menu.
 \triangleleft button: Return to the previous menu.

4. Press the \triangleright or \triangleleft button to position the cursor under the keyboard for which you wish to change the volume.

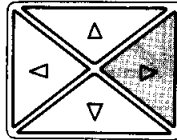
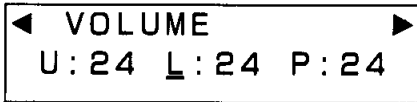

- \triangleright button: Move the cursor to the right.
 \triangleleft button: Move the cursor to the left.

5. Press the \triangleup or \triangledown button to change the volume.

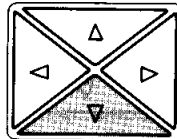
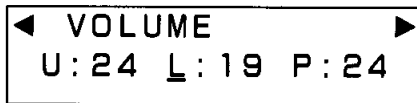

- \triangleup button: Raise the volume level.
 \triangledown button: Lower the volume level.

[Additional Information]

- The volume can be set to one of 24 levels. At level 0 (MIN), the voice will be inaudible. Level 24 (MAX) corresponds to the maximum volume of a voice at the Electone.
- The balance between the volume levels of the upper and lower keyboards can also be adjusted by the Electone's **MANUAL BALANCE** function.

Editing a Voice

Try editing the voice data of the User Voice to create your own unique sound.

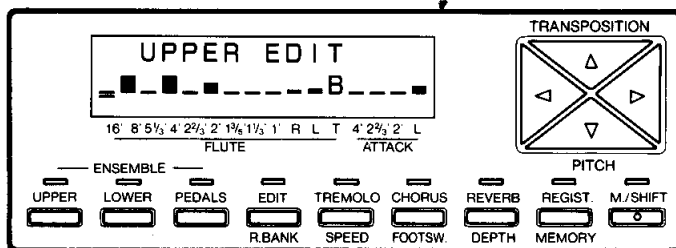

1. Press the \triangleright or \triangleleft button to display the menu of the keyboard for which you wish to edit a voice.

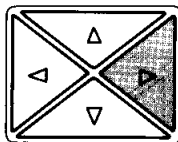
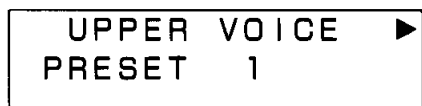

[Additional Information]

■ Because the same voices are shared by both UPPER VOICE and LOWER VOICE, if you edit the USER 11 UPPER VOICE, for example, the USER 11 LOWER VOICE will also be similarly revised.

2. Press the \triangle or ∇ button to choose the User Voice you wish to edit.

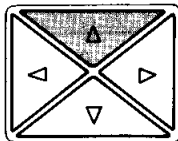
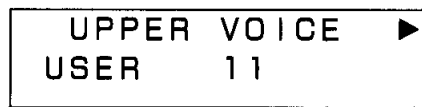

[Additional Information]

■ Each User Voice of the CVS-10 is assigned the same factory-preset voice as the Preset Voice of the corresponding number. For example, User Voice 1 is initially assigned the same voice as Preset Voice 1.

3. Turn ON the EDIT button.

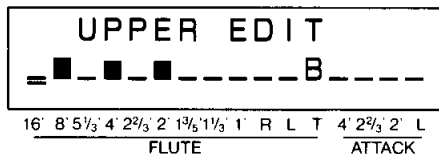

The data of the selected User Voice appears on the display.

[Additional Information]

■ If the EDIT button is pressed without selecting a User Voice, the EDIT button will not come ON.

4. Press the \triangleright or \triangleleft button to position the cursor under the data you wish to revise.

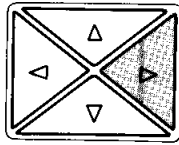
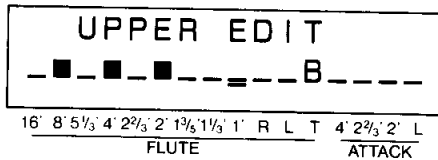

\triangleright button: Move the cursor to the right.
 \triangleleft button: Move the cursor to the left.

5. Press the \triangleup or \triangledown button to change the data.

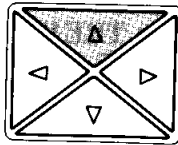
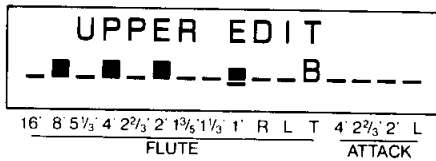

\triangleup button: Raise the level.
 \triangledown button: Lower the level.

Variable Range of the Data

FLUTE, ATTACK	1 (MIN)—7 (MAX)
RESPONSE	1 (SLOW)—7 (FAST)
LENGTH	1 (SHORT)—7 (LONG)
TIMBRE	A (FLUTE)—B (PRINCIPAL)

[Additional Information]

■ If the M./SHIFT button is pressed during editing, all data being edited will be cleared and the original voice data will be restored.

■ If the CVS-10 receives MIDI Registration Change data during editing, all data being edited will be cleared and the original voice data will be restored.

6. When you finish editing the voice, store it as a User Voice by pressing the EDIT button again.



A User Voice can be recalled by performing the same operation used for choosing a Preset Voice. (→page 6)

Adding an Effect

You can also add the TREMOLO, CHORUS, or REVERB effect to a voice.

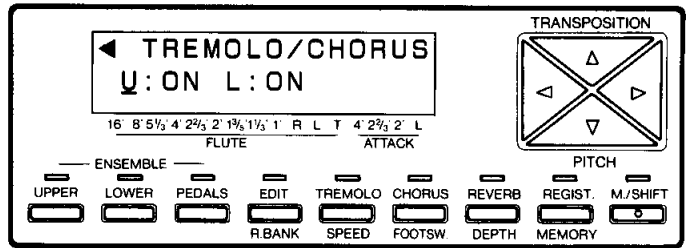

TREMOLO/CHORUS

1. Press the \triangleright or \triangleleft button to display the TREMOLO/CHORUS menu, then check the ON/OFF status of the upper (U) and lower (L) keyboards.

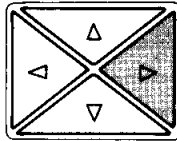
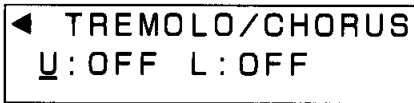

2. To change the ON/OFF status of the TREMOLO/CHORUS effect for a keyboard, position the cursor to select the desired keyboard.

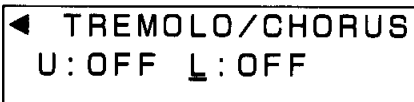

[Additional Information]
 ■ When the TREMOLO/CHORUS menu first appears, the cursor is displayed under the "U" position. To move it to the "L" position, press the \triangleright button.

3. To turn ON the effect, press the \triangle button. To turn it OFF, press the ∇ button.

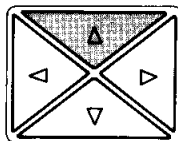
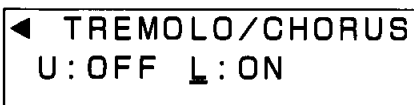

4. Select the TREMOLO/CHORUS mode.



TREMOLO ON: The Tremolo effect is enabled (Tremolo mode).

CHORUS ON: The Chorus effect is enabled (Chorus mode).

Both OFF: A Tremolo effect without trilling of the notes is enabled.

[Additional Information]

■ The ON/OFF status of the Tremolo/Chorus effect for each keyboard is set at Step 1. No matter which mode you choose in Step 4, therefore, the effect will not be added to the keyboard which was turned OFF in Step 1.

5. Set the Tremolo Speed by pressing the TREMOLO button while you hold down the M./SHIFT button.



The currently set Tremolo Speed will appear on the display.

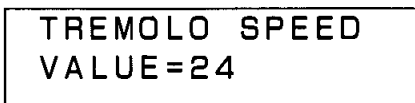

[Additional Information]

■ The Tremolo Speed can be set within a range of 0 (MIN) to 24 (MAX).

■ To select the Tremolo Speed or Foot Switch control function, you must press the TREMOLO or CHORUS button while holding down the M./SHIFT button.

6. Press the Δ or ∇ button to adjust the Tremolo Speed.

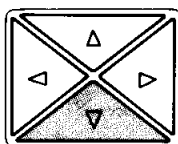
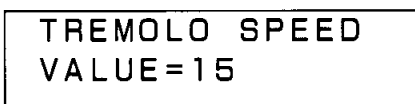

Δ **button:** Increase the Tremolo Speed.
 ∇ **button:** Reduce the Tremolo Speed.

7. When the desired setting is displayed, press the M./SHIFT button.



[Additional Information]

■ Even after you turn OFF the CVS-10's POWER switch, this Tremolo Speed setting will remain unchanged.

To switch between TREMOLO and CHORUS using the Foot Switch

1. Press the CHORUS button while you hold down the M./SHIFT button.



The display below will appear.

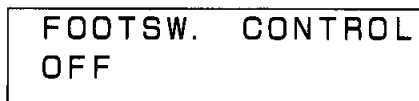

2. To switch Foot Switch control of Tremolo/Chorus mode from OFF to ON, press the Δ button.

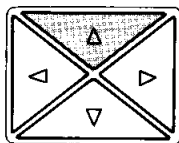
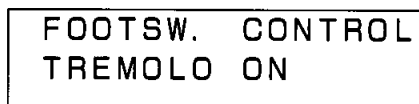

To complete the setting, press the M./SHIFT button once more. You can now switch between the Tremolo and Chorus effects by pressing the Foot Switch to the left.

The bottom row of the display indicates the ON/OFF status of Foot Switch control of the Tremolo mode.
ON: The Foot Switch can control the Tremolo/Chorus mode.
OFF: The Foot Switch cannot control the Tremolo/Chorus mode.

To switch the Foot Switch control setting from TREMOLO ON to TREMOLO OFF, press the ∇ button.

To immediately switch between TREMOLO and CHORUS during a performance

1. Press the Δ , ∇ , \triangleright , or \triangleleft button while you hold down the M./SHIFT and TREMOLO buttons.

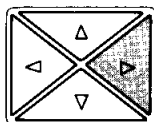

The display below will appear.



2. When you reach a point in your performance where you wish to switch between TREMOLO and CHORUS, press the Δ , ∇ , \triangleright , or \triangleleft button.

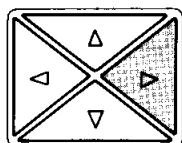

By performing this step, you will later be able to switch between the Tremolo and Chorus effects in realtime.

To cancel this mode, simply repeat Step 1.

REVERB

1. Turn ON the REVERB button.



2. To set the Reverb Depth, first press the REVERB button while you hold down the M./SHIFT button.



The currently set Reverb Depth will appear.

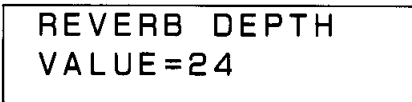

3. Press the Δ or ∇ button to change the Reverb Depth.

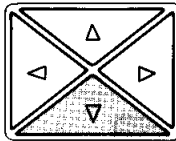
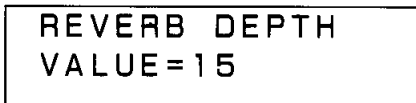

4. When the desired setting is displayed, press the M./SHIFT button.



[Additional Information]

■ The Reverb effect cannot be used if the REVERB button is turned OFF.

[Additional Information]

■ The Reverb Depth can be set within a range of 0 (MIN) to 24 (MAX).

For example, the lowest and highest REVERB buttons on an HS Electone respectively correspond to Depth 0 and 24 on the CVS-10.

■ To select DEPTH, you must press the DEPTH button while you hold down the M./SHIFT button.

Δ button: Increase the depth of reverboration.

∇ button: Reduce the depth of reverboration.

[Additional Information]

■ Even after you turn OFF the CVS-10's POWER switch, this Reverb Depth setting will remain unchanged.

Using the Registrations

The CVS-10 has 4 Registration Banks which can store 16 registrations each, so you can memorize up to 64 of the registrations you set at the CVS-10.

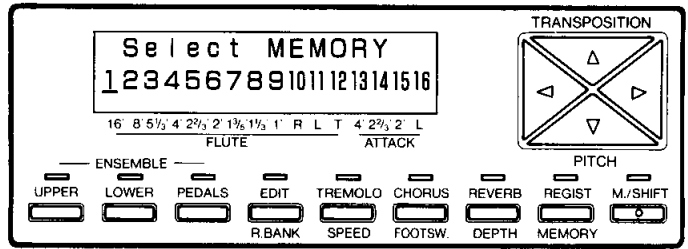

Memorizing a Registration

1. Set a registration at CVS-10.

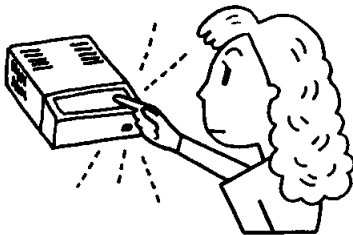

[Additional Information]

- In the memory area reserved for each registration, you can memorize the selected Voice No., volume level, ON/OFF status of effects, Tremolo Speed, and Reverb Depth for each keyboard, as well as the ON/OFF status of the ENSEMBLE buttons.
- If you set the upper keyboard voice to USER 1 and memorize that registration, for example, the data indicating that "USER 1 is selected for the upper keyboard" will be memorized but not the actual voice data of USER 1.

2. To choose a Bank, you must first press the EDIT button while you hold down the M./SHIFT button.

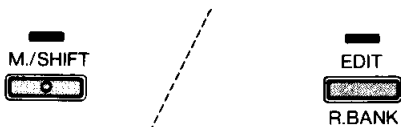

The menu below will be displayed.

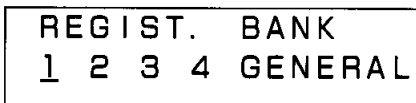

3. Press the \triangleright or \triangleleft button to position the cursor under the Bank No. or under GENERAL, depending on where you wish to memorize the registration.

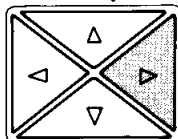
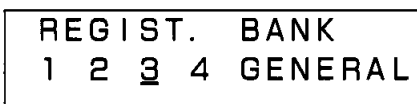

[What is a Bank?]

- If we assume that each registration from 1 to 16 is a member of one family, then each Bank from 1 to 4 can be regarded as a "house." The CVS-10 is provided with four houses (Banks 1 to 4) in which resides one individual 16-member family each as well as one house (GENERAL) in which resides one model family.

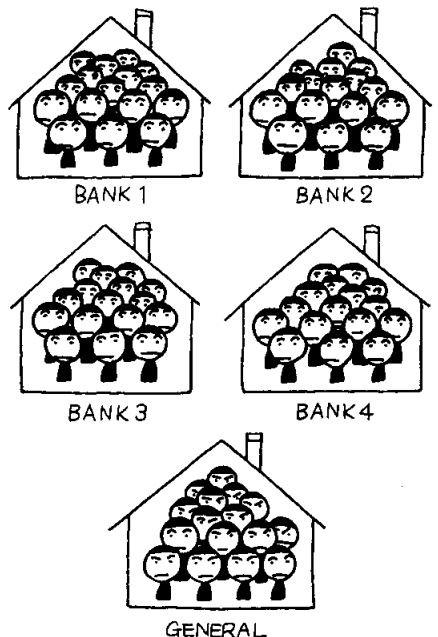

4. When the desired Bank is selected, press the M./SHIFT button.



The previous display is restored.

5. Next, select a Registration No. by pressing the REGIST. button while you hold down the M./SHIFT button.



The menu below will be displayed.

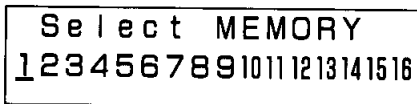

6. Press the > or < button to position the cursor under the number at which you wish to memorize your registration.

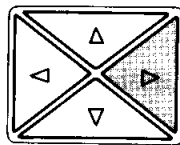
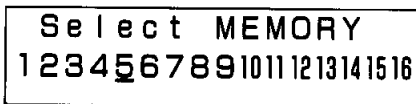

7. To memorize your registration at the selected Registration No., press the REGIST. button.



The message below will be displayed for a few seconds.

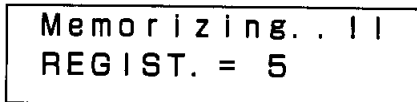

8. To complete the setting, press the M./SHIFT button.



For example, if you select Bank No. 3, the 16 members of the family residing in BANK 3 (shown on page 14) are represented on the display as numbers 1 to 16.

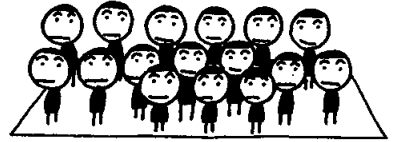

When a Registration No. is selected, one memory area of BANK 3 is selected.

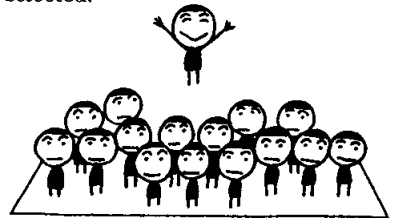

When the REGIST. button is pressed, the registration you have set is memorized in that memory area.

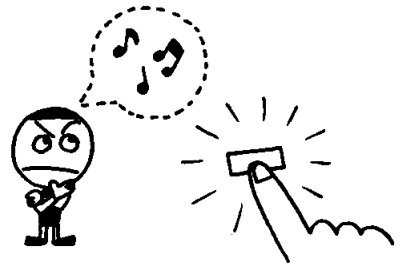

[Additional Information]

■ If you turn OFF the POWER switch and then turn it back ON while you hold down the REGIST. button, the GENERAL Bank will be selected and its memory areas 1-16 will contain the preset GENERAL Registration data. (When this operation is performed, any previously set Registrations in the GENERAL Bank will be cleared.)

■ If you press a different numeric button of REGISTRATION MEMORY at the Electone while the M./SHIFT button of CVS-10 is ON, the registration at the CVS-10 will also be memorized as that same Registration No.

Recalling a Registration

1. Press the **REGIST.** button.



The menu below will be displayed.

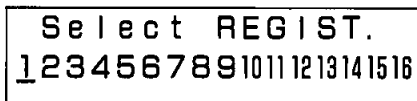

2. Press the **▷** or **◁** button to position the cursor under the number of the desired registration.

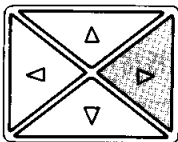
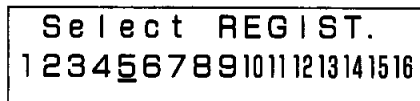

3. To recall the selected registration, press the **REGIST.** button again.



The message below will be displayed for a few seconds.

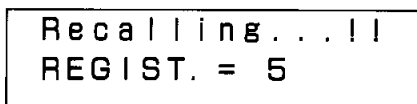

If you wish to switch to another Bank before selecting a Registration No., perform Steps 2, 3, and 4 of "Memorizing a Registration" (page 14), before performing Step 1 on the left.

[Additional Information]

■ Registrations 1-16 of the GENERAL Bank are all provided with preset Registration data (GENERAL PRESETS). If you wish to recall a GENERAL Registration, select the GENERAL Bank first by performing Steps 2, 3, and 4 of "Memorizing a Registration" (page 14).

If you select a different REGISTRATION MEMORY number at the Electone, however, the current Registration No. at the CVS-10 will also change to that same number. Be sure to set each of the CVS-10's Registration No. to the same Registration No. at the Electone (REGISTRATION MEMORY) that you wish to use at the same time.

[Additional Information]

If a disk has been used to record a performance using an Electone+CVS-10+MDR system, that disk cannot be played back when using an Electone+MDR system (without the CVS-10).

SOUND MEMO

Registrations can also be stored in the MDR.

When you connect the CVS-10 to an MDR (Music Disk Recorder) and then perform recording at MDR in Normal mode, the data of the Registrations in the currently selected Bank at CVS-10 will be memorized onto the MDR's disk.

In addition, when playback at MDR is performed in Normal mode, the registrations stored on the MDR's disk will be saved in the currently selected Bank at CVS-10 (and the previous data in that Bank will be erased).

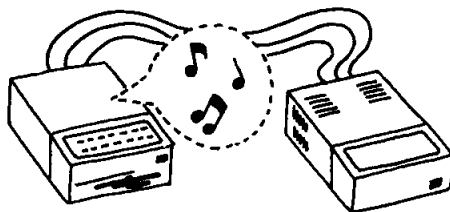

Other Types of Control

The CVS-10 also allows you to finely adjust the pitch, transpose the overall key, perform MIDI control, or change the Attack mode.

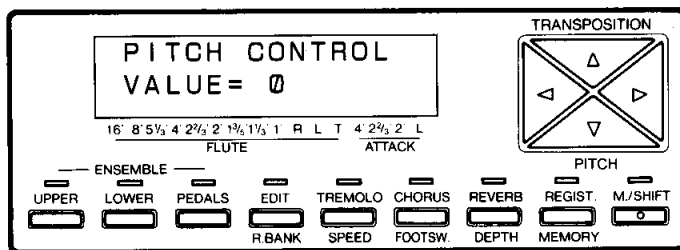

PITCH

1. Press the ∇ button while you hold down the M./SHIFT button.

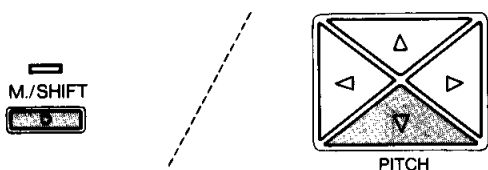

The menu below will be displayed.

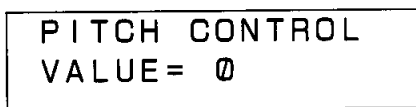

2. Use the Δ or ∇ button to finely adjust the pitch.



Δ button: Each time this button is pressed, the pitch is slightly raised. (When $A_3=440$ Hz, 1 step is equal to about 0.3 Hz over a maximum 15-step range.)

∇ button: Each time this button is pressed, the pitch is slightly lowered. (When $A_3=440$ Hz, 1 step is equal to about 0.3 Hz over a maximum 4-step range.)

[Additional Information]

■ The variable ranges described above are identical to those of the Electone's PITCH CONTROL function.

3. When the desired pitch is displayed, press the M./SHIFT button.



TRANSPOSITION

1. Press the Δ button while you hold down the M./SHIFT button.

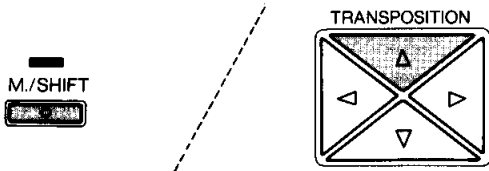

The menu below will be displayed.

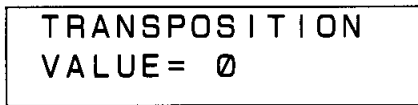

2. Use the Δ or ∇ button to adjust the key.

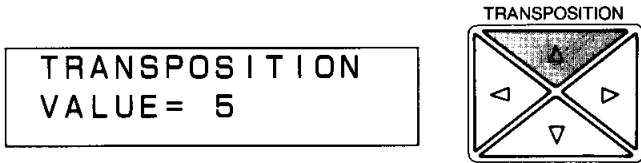

Δ button (Higher key)

Normal Key	$\Delta \times 1$	$\Delta \times 2$	$\Delta \times 3$	$\Delta \times 4$	$\Delta \times 5$	$\Delta \times 6$
C	C# (Db)	D	D# (Eb)	E	F	F# (Gb)

∇ button (Lower key)

Normal Key	$\nabla \times 1$	$\nabla \times 2$	$\nabla \times 3$	$\nabla \times 4$	$\nabla \times 5$	$\nabla \times 6$
C	B	Bb (A#)	A	Ab (G#)	G	Gb (F#)

3. When the desired Transposition value is displayed, press the M./SHIFT button.



Δ button: Each time this button is pressed, the key is raised one half-step (for a maximum of six half-steps).
 ∇ button: Each time this button is pressed, the key is lowered one half-step (for a maximum of six half-steps).

[Additional Information]

■ The variable ranges described above are identical to those of the Electone's TRANSPOSITION function.

MIDI CONTROL

Changing the MIDI Receive Channel Nos.

Although this operation is usually not required, it can be useful when you wish, for example, to provide a CVS-10 organ sound with greater richness, to sound a PEDALS voice from the upper (or lower) keyboard, and so on.

Example

Let's assume that you have set the MIDI Receive Channel Nos. to "1" for the upper keyboard, "2" for the lower keyboard, and "2" for the pedal keyboard. Now, when you play the upper keyboard, the "UPPER VOICE" will be sounded; and when you play the lower keyboard, both the "LOWER VOICE" and "PEDALS VOICE" will be sounded. This method can be used when you wish to combine the bass notes with the part you perform using the left hand.

```
RECEIVE CHANNEL
U: 1 L: 2 P: 3
```

1. Press the ▽ button while you hold down the REGIST. button.

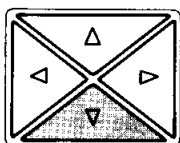

The menu below will be displayed.

```
RECEIVE CHANNEL
U: 1 L: 2 P: 3
```

The MIDI Receive Channels for the upper, lower, and pedal keyboards are pre-assigned with the numbers below:

- 1 = Received by the upper keyboard.
- 2 = Received by the lower keyboard.
- 3 = Received by the pedal keyboard.

2. Press the ▷ or ◁ button to position the cursor at the keyboard for which you wish to change the Channel No.

```
RECEIVE CHANNEL
U: 1 L: 2 P: 3
```

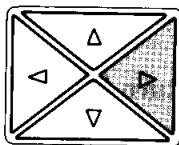

- ▷ button: Move the cursor to the right.
- ◁ button: Move the cursor to the left.

U: Channel No. of the upper keyboard.
L: Channel No. of the lower keyboard.
P: Channel No. of the pedal keyboard.

3. Press the Δ or ∇ button to change the Channel No.

RECEIVE CHANNEL
U: 1 L: 1 P: 3

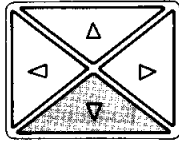

Δ button: Increase the Channel No.
 ∇ button: Decrease the Channel No.

4. To complete the setting, press the M./SHIFT button.



Setting MIDI Transfer to SLEEP Mode

Although this operation is usually not required, it may be useful if you have connected the Electone and the CVS-10 to an MDR (Music Disk Recorder).

Example

- This operation can be used in the following cases:
- After recording only the Electone's data at MDR without using the CVS-10, when you wish to perform playback at MDR without disconnecting the CVS-10.
 - When you wish to transfer data only between the Electone and the MDR. (Other cases when you wish to simulate the status of a direct connection between the Electone and the MDR.)

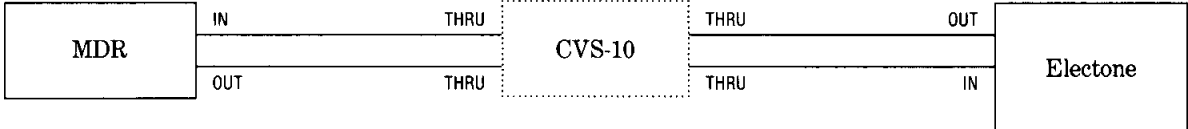

1. Turn OFF the POWER switch, then turn it back ON while you hold down the Δ button.

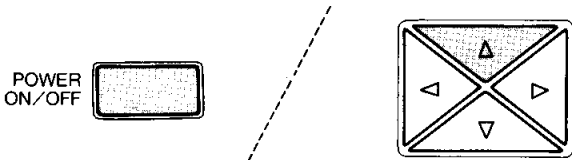

To cancel this mode, turn off the POWER switch.

The message below is displayed to indicate that the CVS-10 is in SLEEP mode (data will simply pass THROUGH the CVS-10 without being processed).

YAMAHA CVS-10
I'm sleeping...

Changing the Attack Mode

1. Press the \triangleright button while you hold down the M./SHIFT button.

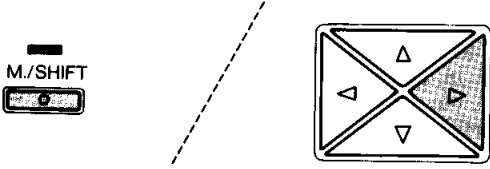

The menu below is displayed.



2. Press the \triangle or ∇ button to change the Attack mode.

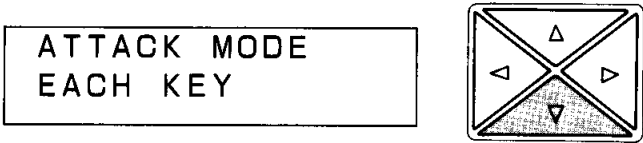

\triangle button: Select FIRST NEW KEY mode.

∇ button: Select EACH KEY mode.

3. To complete the setting, press the M./SHIFT button.



ATTACK MODE: Indicates how the Attack is to be applied to the notes when the keys are pressed.

FIRST NEW KEY mode: Only the first key pressed is sounded using the Attack Rate, and subsequent notes are sounded according to the Envelope Generator level of the first note. (This Attack mode is identical to that of an HX Electone.)

EACH KEY mode: Each time a pressed key is sounded using the Attack Rate. (This Attack mode is identical to that of an HS Electone.)

FOR YOUR REFERENCE

Troubleshooting

Please note that the appearance of any of the following phenomena does not indicate a mechanical failure of the CVS-10.

Phenomenon	Cause and Solution
The CVS-10 is turned ON, but no sound is produced from the Electone's keyboard.	① The MIDI cables, LINE cables, and/or the power adapter are not properly connected. For example, the MIDI IN and OUT cables are connected in reverse, the MIDI-1 and MIDI-2 cables are improperly connected, etc. (→page 3) ② The pertinent ENSEMBLE button is OFF. (→page 5) ③ The volume for the pertinent keyboard is set to "0". (→page 7) ④ A User Voice is selected but its data has all been set to "0" (the lowest value). (→page 8) ⑤ The MIDI Receive Channel No. is set to receive the data sent from a different keyboard than the one which you are playing. (→page 19)
CVS-10 is connected to a stereo, but either no sound is produced from the stereo, or its volume is too small or too loud, the sound is distorted, etc.	① If no sound is produced: The LINE cables are improperly connected. For example, the AUX IN jack of CVS-10 is connected to the LINE OUT jack of the stereo, etc. (→page 3) ② If the volume is too small or too loud, the sound is distorted, etc.: Either the LINE OUT selector switch is improperly set, or the connection to the Electone's AUX IN or EXP IN jack is incorrect. (→page 3)
The volume balance between the upper and lower keyboards differs from the volume settings performed at the CVS-10.	The volume settings at the CVS-10 are being affected by the Manual Balance setting at the Electone. The volume balance between the upper and lower keyboards is designed to be set by the Electone's Manual Balance function. If you want the volume balance to be solely controlled by the CVS-10, set the Electone's Manual Balance function to the center level.
The EDIT button is pressed, but the EDIT mode is not entered.	When choosing the voice to be edited, you have mistakenly chosen a Preset Voice instead of a User Voice. (→page 8)
The Tremolo or Chorus effect is not produced.	① The Tremolo or Chorus effect is disabled. (→page 10) ② The Tremolo Speed is set to "0". (→page 11)
The Reverb effect is not produced.	The Reverb Depth is set to "0". (→page 13)
Certain keys of the lower (or upper) keyboard are sounded as notes in the next higher octave (or are not sounded).	After the overall key has been lowered using the Transposition function, the C to F keys at the left side of the lower keyboard may be sounded as notes in the next higher octave. When the overall key has been raised, the A to C keys at the right side of the upper keyboard may not be sounded.
The functions do not operate properly.	This may be caused by various reasons. Normal operation can sometimes be restored by turning off the POWER switch, then performing a Power-ON Reset operation. (→page 5)
A crackling sound is sometimes heard.	Noise may be produced when either an electrical appliance is turned ON/OFF or an electric power tool, such as a neon sign or drill, is used in the proximity of the CVS-10. In such case, plug the CVS-10 into an electrical outlet located as far as possible from the device that seems to be the source of the problem.
Interference from radio, TV, wireless radios, etc.	This is caused by the proximity of a high-power broadcasting station or amateur ham radio station.

Specifications

Tone Generator	WM (Wave Memory) and FM (Frequency Modulation); Upper: 8-note polyphonic; Lower: 8-note polyphonic; Pedals: monophonic
Voices	Upper/Lower (16 Preset, 16 User Voices) Flute: 16', 8', 5-1/3', 4', 2-2/3', 2', 1-3/5', 1-1/3', 1'; Attack: 4', 2-2/3', 2'; Pedals (8 Preset, 8 User Voices) Flute: 16', 8', 4'
Ensemble	Upper, Lower, Pedals
Edit	Flute, Attack 1-7; Response 1-7; Length 1-7; Timbre A, B; Data Controller (Δ ∇, ◁ ▷)
Effects/Control	Volume: Upper/Lower/Pedals; Tremolo/Chorus: On/Off (for Upper/Lower), Speed, Footsw.; Reverb On/Off, Depth; Pitch; Transposition
Registration Memory	16 Memories × 4 Banks; 16 Preset Combinations
Other Controls	M./Shift, Power Switch, Stereo/Mono Switch, Impedance Switch (Hi: Electone; Low: Home Stereo)
Indicators	LCD Display, LED Lamps: Upper, Lower, Pedals, Edit, Tremolo, Chorus, Reverb, Regist., M./Shift
Input/Output Jacks	MIDI-1 (In, Out; for Electone), MIDI-2 (In, Out), Aux. In (L, R), Line Out (L, R), DC In
Accessories	MIDI Cable (1.5m × 2), Audio Cable (Stereo; 1.5m), 1-unit Bracket BRT-3 (for HX, HS and HE Electones; optional), 2-unit Bracket BRT-3D (for HX, HS and HE Electones; optional), Power Adaptor PA-W10 (DC In 10V; 700mA - A; not included)
Dimensions (W × D × H)	135 × 200 × 63.5mm (5.3" × 7.9" × 2.5")
Weight	1.1kg (2.4 lbs.)

*Specifications and descriptions in this User's Guide are for information purposes only. Yamaha Corp. reserves the right to change or modify products or specifications at any time without prior notice. As specifications, equipment or options may not be the same in every locale, please check with Yamaha dealer.

CANADA

THIS APPARATUS COMPLIES WITH THE "CLASS B" LIMITS FOR RADIO NOISE EMISSIONS SET OUT IN RADIO INTERFERENCE REGULATIONS.

*This applies only to products distributed by Yamaha Canada Music Ltd.

FCC Information (USA)

While the following statements are provided to comply with FCC Regulations in the United States, the corrective measures listed are applicable worldwide.

The digital series of Yamaha Electones™ use frequencies that appear in the radio frequency range, and if installed in the immediate proximity of some types of audio or video devices within three meters (approximately ten feet), interference may occur.

This series of Yamaha Electones™ has been type-tested and found to comply with the specifications set for a class B computer in accordance with those specifications listed in sub-part J, part 15 of the FCC rules. These rules are designed to provide a reasonable measure of protection against such interference. However, this does not guarantee that interference will not occur.

If your Electone™ should be suspected of causing interference with other electronic devices, verification can be made by turning your Electone™ off and on. If the interference continues when your Electone™ is off, the Electone™ is not the source of the interference. If your Electone™ does appear to be the source of the interference, you should try to correct the situation by using one or more of the following measures:

- Relocate either the Electone™ or the electronic device that is being affected by the interference.
- Utilize power outlets for the Electone™ and the device being affected that are on different branch (circuit breaker or fuse) circuits, or install AC line filters.
- In the case of radio-TV interference, relocate the antenna or if the antenna lead-in is 300 ohm ribbon lead, change the lead-in to coaxial type cable.

If these corrective measures do not produce satisfactory results, please contact an authorized Yamaha Electone™ dealer for suggestions and/or corrective measures. If you can not locate an authorized Yamaha Electone™ dealer in your general area, please contact the Electone™ Service Department, YAMAHA CORPORATION OF AMERICA, U.S.A., 6600 Orangethorpe Ave., Buena Park, CA 90620.

If for any reason, you should need additional information relating to radio or TV interference, you may find a booklet prepared by the Federal Communications Commission helpful: "How to Identify and Resolve Radio-TV Interference Problems." This booklet, Stock #004-000-00345-4, is available from the US. Government Printing Office, Washington DC. 20402.

CVS-10

MIDI Implementation Chart / MIDI-Anwendungstabelle Tableau d'implantation MIDI

Date: 3/20, 1989
Version: 1.0

Functions...		Transmitted	Recognized	Remarks
Basic Channel	Default	x x x	1 2 3	UK (PRESET) LK (PRESET) PK (PRESET)
	Changes	x	1-16	
Mode	Default	Mode 3	Mode 3	
	Messages Altered	x *****	x x	
Note Number		x x x	36-96 36-96 36-96	UK LK PK
	True Voice	*****	36-96	UK, LK, PK
Velocity	Note ON	x	<input type="radio"/> 9nH, v=1-127	
	Note OFF	x	<input type="radio"/> 9nH, v=0, 8nH	
After Touch	Key's	x	x	
	Ch's	x	x	
Pitch Bender		x	x	
Control Change		7 x	<input type="radio"/>	Volume
		8 x	<input type="radio"/>	Manual Balance
		11 x	<input type="radio"/>	Expression Pedal
Program Change		x	0-15	Regist. Memory
	True #	*****	0-15	
System Exclusive		<input type="radio"/> *	<input type="radio"/> *	
System Common	Song Pos	x	x	
	Song Sel	x	x	
	Tune	x	x	
System Real Time	Clock	x	x	
	Commands	x	x	
Aux Messages	Local ON/OFF	x	x	
	All Notes OFF	x	<input type="radio"/>	
	Active Sense	x	<input type="radio"/>	
	Reset	x	<input type="radio"/>	
Notes		* Refer to Exclusive message list.		

Mode 1: OMNI ON , POLY Mode 2: OMNI ON , MONO
Mode 3: OMNI OFF, POLY Mode 4: OMNI OFF, MONO

: YES
x : NO

SYSTEM EXCLUSIVE MESSAGES / SYSTEM-EXKLUSIVMELDUNGEN

MESSAGE EXCLUSIFS DU SYSTEME

Code	Messages	Remarks
F0H, 43H, 70H, 70H (Electone), ..., F7H	1. Electone common messages/Electone-Normalmeldungen/Messages communs de l'Electone	
F0H, 43H, 70H, 2BH (Model),, F7H	2. Model-Specific messages/Modell/Einzelmeldungen/Messages spécifiques au modèle	
F0H, 43H, 70H, 71H,, F7H	3. HX-Series common messages/Normalmeldungen für HX-Serie/Messages communs de la série HX	
F0H, 43H, 70H, 72H,, F7H	4. HS-Series common messages/Normalmeldungen für HS-Serie/Messages communs de la série HS	
F0H, 43H, 70H, 76H,, F7H	5. Expander common messages/Expander-Normalmeldungen/Messages communs de l'expandeur	

1. Electone common messages/Electone-Normalmeldungen/Messages communs de l'Electone

F0H, 43H, 70H, 70H, ... (code) ..., F7H

Code	Messages	Trans.	Recog.
00H, ... (data) ...	Bulk dump data	×	○
10H	Request-to-send all RAM data	○	○
20H	Request-to-receive all RAM data	○	○
30H	Request-to-send Model ID data	○	○
40H, 45H, (data)	Foot Sw data	×	○
40H, 60H, xxH	Tremolo Control	○ (MIDI-2)	○
43H, (data)	Regist. Memory	×	○
70H, 01H	MDR Play start	×	○
70H, 03H	MDR Record start	×	○

xx 00: off 01: Tremolo 2: Chorus

2. Model-specific messages/Modell-Einzelmeldungen/Messages spécifiques au modèle

F0H, 43H, 70H, 2BH (Model), ... (code) ..., F7H

Code	Messages	Trans.	Recog.
00H, ... (data) ...	Bulk dump data	○	○
00H	Model ID data	○	×
10H	Request-to-send all RAM data	×	○
20H	Request-to-receive all RAM data	×	○
30H	Request-to-send Model ID data	×	○
42H	Current Request data	○	○

3. HX-Series common messages/Normalmeldungen für HX-Serie/Messages communs de la série HX

F0H, 43H, 70H, 71H, ... (code) ..., F7H

Code	Messages	Trans.	Recog.
41H, 1EH, xxH	Manual Balance	×	○

xx = 00H, 04H, 08H, 0CH, 10H, 14H, 18H

4. HS-Series common messages/Normalmeldungen für HS-Serie/Messages communs de la série HS

F0H, 43H, 70H, 72H, ... (code) ..., F7H

Code	Messages	Trans.	Recog.
41H, 20H, xxH	Manual Balance	×	○

xx = 00H-0CH

5. Expander common messages/Expander-Normalmeldungen/Messages communs de l'expandeur

F0H, 43H, 70H, 76H, ... (code) ..., F7H

Code	Messages	Trans.	Recog.
00H, ... (data) ...	Bulk dump data	○	○

YAMAHA
YAMAHA CORPORATION
P.O.Box 1, Hamamatsu, Japan