

# YAMAHA *Clavinova*

**CVP-87A**  
**CVP-85A**  
**CVP-83S**

**Owner's Manual**

## **IMPORTANT**

### **Check Your Power Supply**

Make sure that your local AC mains voltage matches the voltage specified on the name plate on the bottom panel. In some areas a voltage selector may be provided on the bottom panel of the main keyboard unit near the power cord (CVP-87A and CVP-85A) or on the rear panel (CVP-83S). Make sure that the voltage selector is set for the voltage in your area.

# SPECIAL MESSAGE SECTION

**PRODUCT SAFETY MARKINGS:** Yamaha electronic products may have either labels similar to the graphics shown below or molded/stamped facsimiles of these graphics on the enclosure. The explanation of these graphics appears on this page. Please observe all cautions indicated on this page and those indicated in the safety instruction section.

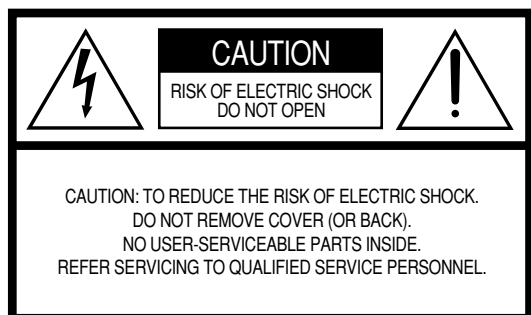

See bottom of Keyboard enclosure for graphic symbol markings



The exclamation point with the equilateral triangle is intended to alert the user to the presence of important operating and maintenance (servicing) instructions in the literature accompanying the product.

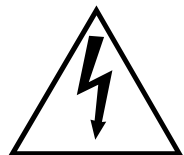

The lightning flash with arrowhead symbol within the equilateral triangle is intended to alert the user to the presence of uninsulated “dangerous voltage” within the product’s enclosure that may be of sufficient magnitude to constitute a risk of electrical shock.

**IMPORTANT NOTICE:** All Yamaha electronic products are tested and approved by an independent safety testing laboratory in order that you may be sure that when it is properly installed and used in its normal and customary manner, all foreseeable risks have been eliminated. DO NOT modify this unit or commission others to do so unless specifically authorized by Yamaha. Product performance and/or safety standards may be diminished. Claims filed under the expressed warranty may be denied if the unit is/has been modified. Implied warranties may also be affected.

**SPECIFICATIONS SUBJECT TO CHANGE:** The information contained in this manual is believed to be correct at the time of printing. However, Yamaha reserves the right to change or modify any of the specifications without notice or obligation to update existing units.

**ENVIRONMENTAL ISSUES:** Yamaha strives to produce products that are both user safe and environmentally friendly. We sincerely believe that our products and the production methods used to produce them, meet these goals. In keeping with both the letter and the spirit of the law, we want you to be aware of the following:

**Battery Notice:** This product MAY contain a small non-rechargeable battery which (if applicable) is soldered in place. The average life span of this type of battery is approximately five years. When replacement becomes necessary, contact a qualified service representative to perform the replacement.

**Warning:** Do not attempt to recharge, disassemble, or incinerate this type of battery. Keep all batteries away from children. Dispose of used batteries promptly and as regulated by applicable laws. Note: In some areas, the servicer is required by law to return the defective parts. However, you do have the option of having the servicer dispose of these parts for you.

**Disposal Notice:** Should this product become damaged beyond repair, or for some reason its useful life is considered to be at an end, please observe all local, state, and federal regulations that relate to the disposal of products that contain lead, batteries, plastics, etc.

**NOTICE:** Service charges incurred due to lack of knowledge relating to how a function or effect works (when the unit is operating as designed) are not covered by the manufacturer’s warranty, and are therefore the owners responsibility. Please study this manual carefully and consult your dealer before requesting service.

**NAME PLATE LOCATION:** The graphic below indicates the location of the name plate. The model number, serial number, power requirements, etc., are located on this plate. You should record the model number, serial number, and the date of purchase in the spaces provided below and retain this manual as a permanent record of your purchase.

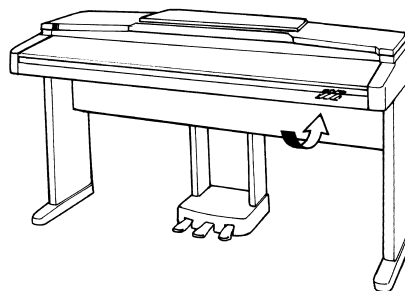

**Model** \_\_\_\_\_

**Serial No.** \_\_\_\_\_

**Purchase Date** \_\_\_\_\_

# IMPORTANT SAFETY INSTRUCTIONS

## INFORMATION RELATING TO PERSONAL INJURY, ELECTRICAL SHOCK, AND FIRE HAZARD POSSIBILITIES HAS BEEN INCLUDED IN THIS LIST.

**WARNING-** When using any electrical or electronic product, basic precautions should always be followed. These precautions include, but are not limited to, the following:

- 1.** Read all Safety Instructions, Installation Instructions, Special Message Section items, and any Assembly Instructions found in this manual **BEFORE** making any connections, including connection to the main supply.
- 2.** Main Power Supply Verification: Yamaha products are manufactured specifically for the supply voltage in the area where they are to be sold. If you should move, or if any doubt exists about the supply voltage in your area, please contact your dealer for supply voltage verification and (if applicable) instructions. The required supply voltage is printed on the name plate. For name plate location, please refer to the graphic found in the Special Message Section of this manual.
- 3.** This product may be equipped with a polarized plug (one blade wider than the other). If you are unable to insert the plug into the outlet, turn the plug over and try again. If the problem persists, contact an electrician to have the obsolete outlet replaced. Do **NOT** defeat the safety purpose of the plug.
- 4.** Some electronic products utilize external power supplies or adapters. Do **NOT** connect this type of product to any power supply or adapter other than one described in the owners manual, on the name plate, or specifically recommended by Yamaha.
- 5.** **WARNING:** Do not place this product or any other objects on the power cord or place it in a position where anyone could walk on, trip over, or roll anything over power or connecting cords of any kind. The use of an extension cord is not recommended! If you must use an extension cord, the minimum wire size for a 25' cord (or less) is 18 AWG. **NOTE:** The smaller the AWG number, the larger the current handling capacity. For longer extension cords, consult a local electrician.
- 6.** Ventilation: Electronic products, unless specifically designed for enclosed installations, should be placed in locations that do not interfere with proper ventilation. If instructions for enclosed installations are not provided, it must be assumed that unobstructed ventilation is required.
- 7.** Temperature considerations: Electronic products should be installed in locations that do not significantly contribute to their operating temperature. Placement of this product close to heat sources such as; radiators, heat registers and other devices that produce heat should be avoided.
- 8.** This product was **NOT** designed for use in wet/damp locations and should not be used near water or exposed to rain. Examples of wet/damp locations are; near a swimming pool, spa, tub, sink, or wet basement.
- 9.** This product should be used only with the components supplied or; a cart, rack, or stand that is recommended by the manufacturer. If a cart, rack, or stand is used, please observe all safety markings and instructions that accompany the accessory product.
- 10.** The power supply cord (plug) should be disconnected from the outlet when electronic products are to be left unused for extended periods of time. Cords should also be disconnected when there is a high probability of lightening and/or electrical storm activity.
- 11.** Care should be taken that objects do not fall and liquids are not spilled into the enclosure through any openings that may exist.
- 12.** Electrical/electronic products should be serviced by a qualified service person when:
  - a. The power supply cord has been damaged; or
  - b. Objects have fallen, been inserted, or liquids have been spilled into the enclosure through openings; or
  - c. The product has been exposed to rain; or
  - d. The product does not operate, exhibits a marked change in performance; or
  - e. The product has been dropped, or the enclosure of the product has been damaged.
- 13.** Do not attempt to service this product beyond that described in the user-maintenance instructions. All other servicing should be referred to qualified service personnel.
- 14.** This product, either alone or in combination with an amplifier and headphones or speaker/s, may be capable of producing sound levels that could cause permanent hearing loss. **DO NOT** operate for a long period of time at a high volume level or at a level that is uncomfortable. If you experience any hearing loss or ringing in the ears, you should consult an audiologist. **IMPORTANT:** The louder the sound, the shorter the time period before damage occurs.
- 15.** Some Yamaha products may have benches and/or accessory mounting fixtures that are either supplied as a part of the product or as optional accessories. Some of these items are designed to be dealer assembled or installed. Please make sure that benches are stable and any optional fixtures (where applicable) are well secured **BEFORE** using. Benches supplied by Yamaha are designed for seating only. No other uses are recommended.

## PLEASE KEEP THIS MANUAL

# Introduction

Thank you for choosing a Yamaha Clavinova. Your Clavinova is a fine musical instrument that employs advanced Yamaha music technology. With the proper care, your Clavinova will give you many years of musical pleasure.

- AWM (Advanced Wave Memory) tone generator system offers a range of 60 rich, realistic voices.
- A maximum of 32-note polyphony permits use of sophisticated playing techniques.
- Piano-like touch response provides extensive expressive control and outstanding playability.
- Dual and split play modes allow 2 voices to be played simultaneously or individually with the left and right hands.
- 24 exciting accompaniment styles can be used to provide rhythm-only accompaniment or fully-orchestrated rhythm, bass, and chord accompaniment. 40 additional accompaniment styles are provided on floppy disk (Style Disk).
- Full-keyboard ABC (Auto Bass Chord) provides accompaniment as you play across the entire keyboard.
- 24 Solo Styleplay variations make it simple to produce rich, complex harmonies.
- 10-track performance memory records and plays back your keyboard performances.
- Internal 3.5" floppy disk drive provides extended Performance Memory capacity and Disk Orchestra playback capability – one blank floppy disk for recording and one Disk Orchestra Collection disk with corresponding score are provided.
- MIDI compatibility, GM voices, and a range of MIDI functions make the Clavinova useful in a range of advanced MIDI music systems.

In order to make the most of your Clavinova's performance potential and features, we urge you to read this Owner's Manual thoroughly, and keep it in a safe place for later reference.

<b>Taking Care of Your Clavinova</b> .....	1	<b>Auto Bass Chord (ABC)</b> .....	20	<b>Utility Mode 1</b> .....	41
<b>The Panel Controls</b> .....	2	■ Single-finger Accompaniment .....	20	U1: Touch Sensitivity .....	41
<b>Preparation</b> .....	4	■ Fingered Accompaniment .....	21	U2: Accompaniment Volume Mode .....	42
<b>The Volume Controls</b> .....	5	■ Full-keyboard ABC .....	22	U3: Individual Key Tuning .....	42
<b>Demonstration Playback</b> .....	6	■ Volume Control .....	22	U4: Style Tempo Switching .....	42
<b>Voice Selection</b> .....	7	■ Changing the ABC Split Point .....	22	U5: Auto Synchro Start Switching .....	43
■ Selecting the 60 Voices .....	7	■ Special Modes .....	22	U6: Random All Song Repeat .....	43
■ Keyboard Percussion .....	8	<b>Disk Styles</b> .....	23	U7: Octave Shift .....	43
<b>Dual Mode</b> .....	9	■ Selecting & Loading Disk Styles .....	23	U8: Mute .....	43
■ Engaging the Dual Mode .....	9	■ Using a Loaded Disk Style .....	24	U9: Minor Harmonization .....	43
■ Dual-mode Voice Balance .....	9	<b>Solo Styleplay</b> .....	25	UA: Damper Pedal Mode (CVP-87A only) .....	43
<b>Split Mode</b> .....	10	■ Using Solo Styleplay .....	25	Ub: Standard MIDI File Playback Mode .....	43
■ Engaging the Split Mode .....	10	■ Harmonization Variations .....	25	<b>Utility Mode 2</b> .....	44
■ Changing the Split Voices .....	10	■ The Left Pedal & Solo Styleplay .....	25	u1: Clavinova Common Voice Conversion .....	44
■ Changing the Split Point .....	10	<b>Disk Orchestra</b> .....	26	u2: Save Panel Settings .....	45
■ Split Balance .....	11	■ Automatic Performance .....	26	u3: Load Panel Settings .....	45
■ Damper Pedal Operation in the Split Mode .....	11	■ Playing Back only Specific Parts .....	27	u4: Save Individual Key Tuning .....	45
<b>Digital Reverb Effects</b> .....	12	■ Volume Control .....	28	u5: Load Individual Key Tuning .....	46
■ Selecting a Reverb Effect .....	12	■ Guided Right- and Left-hand Practice ..	28	u6: Quantize Song Data .....	46
■ Reverb Depth Control .....	12	■ Repeat Functions .....	29	<b>MIDI Functions</b> .....	47
<b>The Keyboard &amp; Polyphony</b> .....	13	■ Other Playback Controls .....	30	■ Send and Receive Channel Select ....	47
<b>The Pedals</b> .....	14	■ DISK ORCHESTRA COLLECTION		■ Local Control ON/OFF .....	48
■ Right Pedal (Damper Pedal) .....	14	Disk Copy .....	30	■ Program Change ON/OFF .....	48
■ Center Pedal (Sostenuto Pedal, CVP-87A only) .....	14	■ Playing Other Types of Music Data ...	30	■ Control Change ON/OFF .....	48
■ Left Pedal (Multi-function) .....	14	<b>Performance Memory</b> .....	31	■ The Multi-Timbre Mode .....	49
<b>Pan</b> .....	15	<b>Easy One-pass Recording &amp; Playback</b> ..	31	■ The Split Send Mode .....	49
<b>Transposition</b> .....	15	<b>Multi-track Recording &amp; Playback</b> ....	32	■ MIDI Clock Select .....	50
<b>Pitch Control</b> .....	16	■ Adding New Tracks .....	34	■ Panel Data Send .....	50
■ The Pitch Display .....	16	■ Punch-in Recording .....	35	■ MIDI Transpose Transmit .....	50
<b>Accompaniment</b> .....	17	■ Playback .....	36	■ The Clavinova Common Voice Mode ..	50
■ Style Selection .....	17	<b>The Chord Sequence Function</b> .....	37	<b>The Connectors</b> .....	51
■ Tempo Control .....	17	<b>Disk Control</b> .....	38	<b>Troubleshooting</b> .....	52
■ Starting the Accompaniment .....	18	■ Formatting a New Disk .....	38	<b>Options</b> .....	52
■ Fill-ins .....	19	■ Copying Songs .....	39	<b>Index</b> .....	53
■ Stopping the Accompaniment .....	19	■ Deleting a Song .....	40	<b>Assembly</b> .....	i
■ Metronome .....	19	■ Error Messages .....	40	<b>MIDI Data Format</b> .....	vii
				<b>Specifications</b> .....	xi
				<b>Fingering Chart</b> .....	xii
				<b>MIDI Implementation Chart</b> .....	xvii

Your Clavinova will give you years of playing pleasure if you observe the simple rules given below:

## 1. Avoid Humidity & Heat

Avoid placing the Clavinova in areas that are subject to excessive humidity or heat. Do not leave the instrument near heaters or in a car exposed to direct sunlight, for example.

## 2. Avoid Dust & Moisture

Avoid locations in which the instrument is likely to be exposed to excessive dust or moisture.

## 3. Power-off Before Connecting

Connections between the Clavinova and any other device must be made with both pieces of equipment turned off.

## 4. Handle With Care

Never apply excessive force to the controls, connectors or other parts of your Clavinova, and avoid scratching or bumping it with hard objects. Further, always turn the POWER switch off after use, and close the key cover to protect the keyboard (CVP-87A and CVP-85A), or cover the instrument with the dust cover provided (CVP-83S).

## 5. Clean Carefully

Clean the cabinet and keys of your Clavinova only with a clean, slightly damp cloth. A neutral cleanser may be used if desired. Never use abrasive cleansers, waxes, solvents or chemical dust cloths since these can dull or damage the finish.

## 6. Never Tamper With the Internal Circuitry

Never open the Clavinova cabinet and touch or tamper with the internal circuitry. Tampering with the circuitry can result in electrical shock!

## 7. Electric Interference

Since the Clavinova contains digital circuitry, it may cause interference if placed too close to radio or television receivers. If this occurs, move the instrument further away from the affected equipment.

## 8. Check Your Power Supply

Make sure that your local AC mains voltage matches the voltage specified on the name plate on the bottom panel. In some areas a voltage selector may be provided on the bottom panel of the main keyboard unit near the power cord (CVP-87A and CVP-85A) or on the rear panel (CVP-83S). Make sure that the voltage selector is set for the voltage in your area.

## 9. Name Plate Location

The Clavinova name plate, including the unit's serial number, is located on the bottom panel of the main unit.

## 10. Handling Floppy Disks

Yamaha Disk Orchestra Collection and Style Disk are write-protected, and therefore cannot be used to save songs. To save Performance Memory songs from the Performance Memory, a blank floppy disk should be used (one blank disk is supplied with the Clavinova).

### Taking Care of Your Floppy Disks

- Do NOT eject the disk during recording or playback, or at any time when the disk drive lamp is lit. Doing so may damage both the disk and the FDD.
- Do NOT turn the Clavinova on or off while the disk is in the drive.
- Always eject the disk before turning the Clavinova off.
- When ejecting a floppy disk from the disk drive:

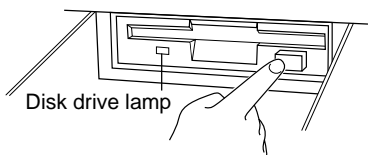

- To eject a floppy disk, press the eject button slowly as far as it will go. Then when the disk is fully ejected, remove it by hand.
  - The disk may not be ejected properly if the eject button is pressed too quickly or if it is not pressed in far enough. (The eject button may become stuck halfway with the disk extending from the slot by only a few millimeters). If this is the case, do not attempt to pull out the partially ejected disk. Doing so may damage the disk drive mechanism and/or the floppy disk. To remove a partially ejected disk, try pressing the eject button once again or push the disk back into the slot, then repeat the eject procedure carefully.
- Never open or close the key cover while a disk is extending from the drive (i.e. in the ejected position). The key cover may contact the disk, possibly damaging the disk or even the disk drive.
  - Do not insert anything but floppy disks into the disk drive. Other objects may cause damage to the disk drive or floppy disk.
  - Use only double-sided double density (2DD) 3.5-inch floppy disks with the Clavinova.

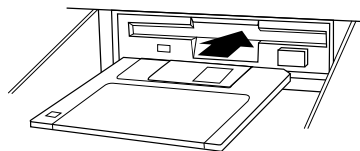

### Precautions Regarding Floppy Disk Use

- Never open the disk's shutter. Dirt or dust on the internal magnetic surface will cause data errors.
- Never leave disks near a speaker, TV, or other device that emits a strong magnetic field.
- Do not store disks in places exposed to direct sunlight or sources of high temperature.
- Do not place heavy objects such as books on top of a disk.
- Avoid getting the disks wet.
- Be sure to store the disks in environmental conditions as specified below:
  - Storage temperature: 4° to 53°C (39° to 127°F).
  - Storage humidity: 8 to 90% relative humidity.
  - Store in an area free from dust, sand, smoke, etc.
- Be sure to apply the disk label at the proper position. When changing the label never cover the old label with a new label; always remove the old label first.

### Head Cleaning

The head of the disk drive unit will get dirty as you use it eventually causing data errors. If this occurs, clean the head with a 3.5 inch head cleaning disk (available from most computer supply stores).

### Data Backup

It is recommended that you copy your recorded songs to another disk for backup (see page 39). If the original disk is damaged or your song is deleted, the backup disk can be used instead of the original.

### Protecting Your Data (Write Protect Tab)

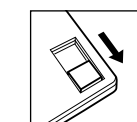
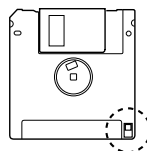

Write protect tab open (locked — write protected)

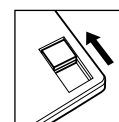

Write protect tab closed (unlocked — write enabled)



# 2 The Panel Controls

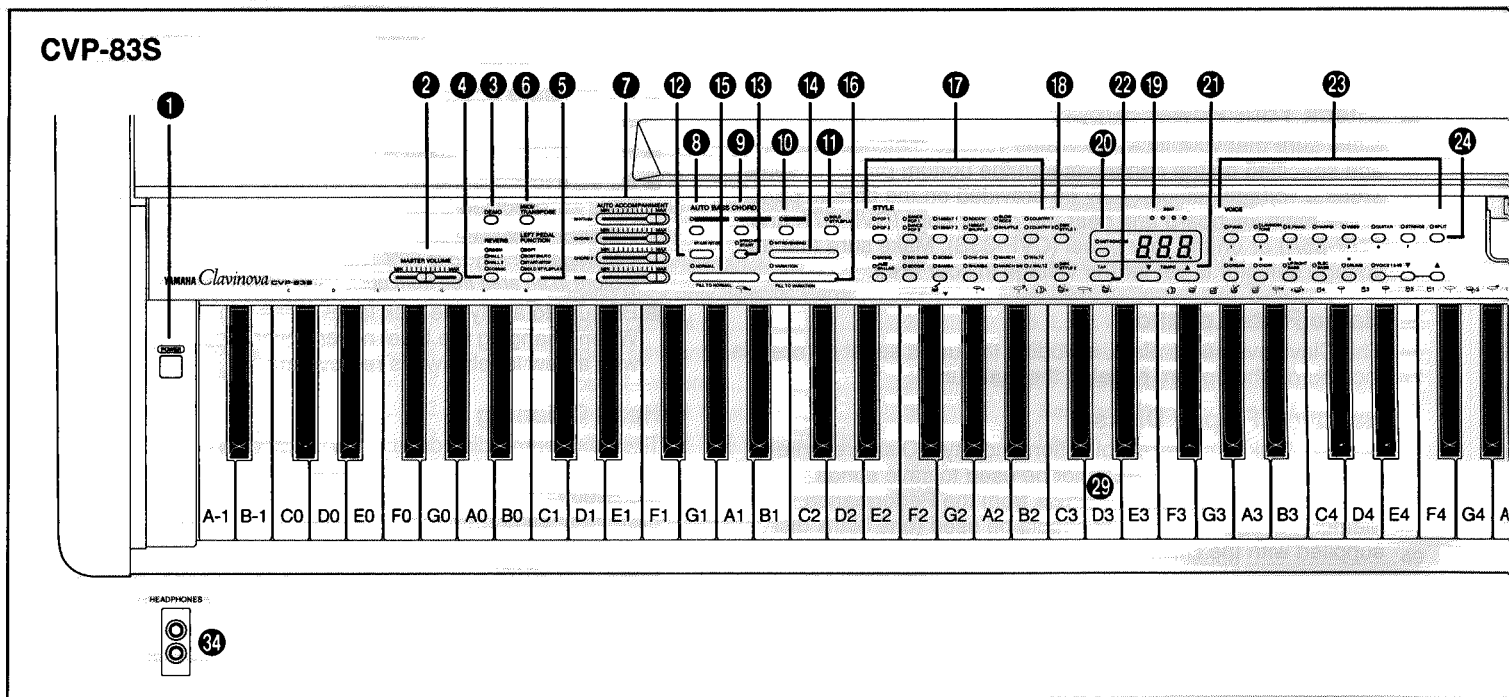
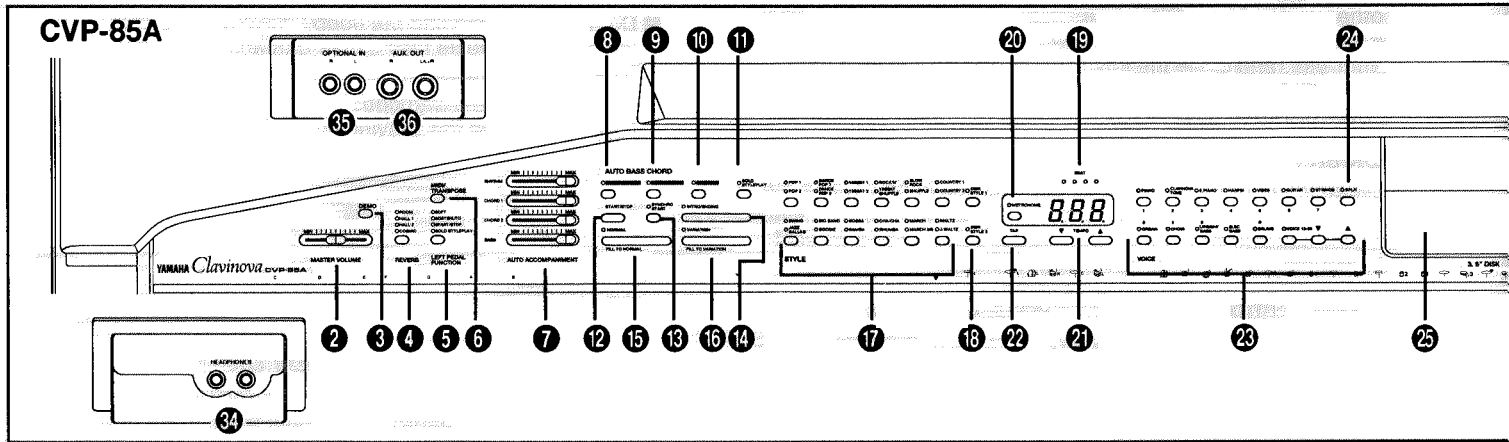
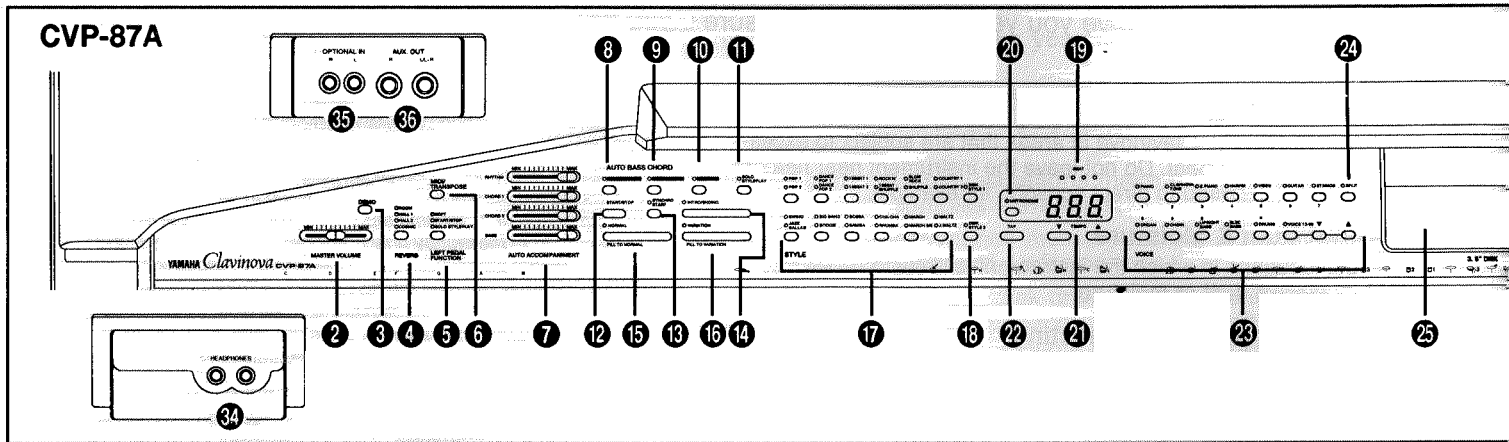

CVP-87A

CVP-87A

CVP-85A/83S

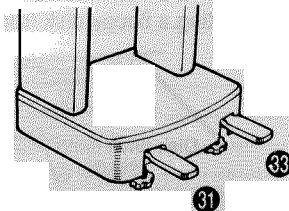
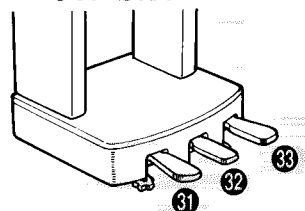
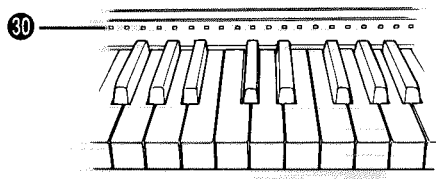

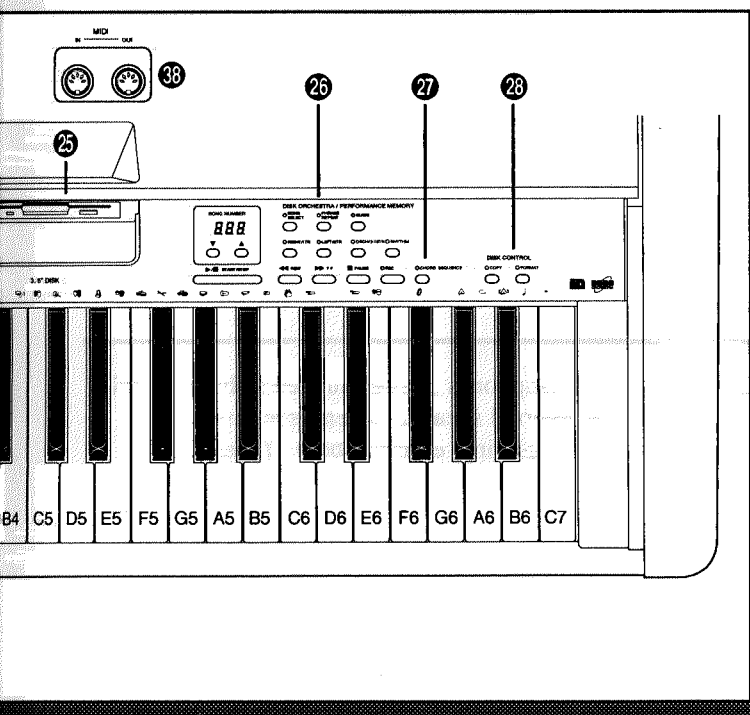
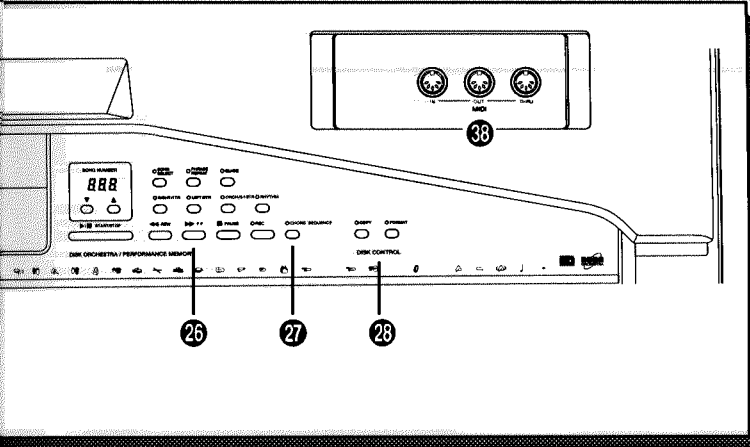
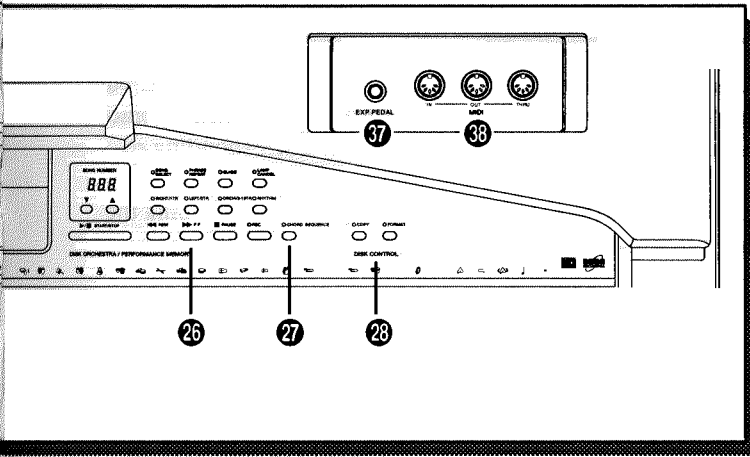

- 1 POWER Switch ..... page 4
- 2 MASTER VOLUME Control ..... page 5
- 3 [DEMO] Button ..... page 6
- 4 [REVERB] Button ..... page 12
- 5 [LEFT PEDAL FUNCTION] Button ..... page 14
- 6 [MIDI/TRANSPOSE] Button ..... page 5, 15, 29, 34, 41-50
- 7 AUTO ACCOMPANIMENT Volume Controls .... page 5, 22
- 8 AUTO BASS CHORD [FULL KEYBOARD] Button . page 22
- 9 AUTO BASS CHORD [SINGLE FINGER] Button . page 20
- 10 AUTO BASS CHORD [FINGERED] Button ..... page 21
- 11 [SOLO STYLEPLAY] Button ..... page 25
- 12 [START/STOP] Button ..... page 18, 19
- 13 [SYNCHRO START] Button ..... page 18
- 14 [INTRO/ENDING] Button ..... page 18, 19
- 15 [NORMAL/FILL TO NORMAL] Button ..... page 18, 19
- 16 [VARIATION/FILL TO VARIATION] Button ..... page 18, 19
- 17 STYLE Selectors ..... page 17
- 18 [DISK STYLE] Buttons ..... page 23
- 19 BEAT Display ..... page 19
- 20 [METRONOME] Button ..... page 19
- 21 TEMPO Display and [▲] and [▼] Buttons ..... page 17
- 22 [TAP] Button ..... page 19
- 23 VOICE Selectors ..... page 7
- 24 [SPLIT] Button ..... page 10
- 25 3.5" Floppy Disk Drive ..... page 23, 26, 31, 38
- 26 DISK ORCHESTRA/PERFORMANCE MEMORY Display and Buttons ..... page 26, 31
- 27 [CHORD SEQUENCE] Button ..... page 37
- 28 DISK CONTROL Buttons ..... page 38
- 29 Keyboard ..... page 13
- 30 Disk Orchestra Keyboard Guide Lamps (CVP-87A) ..... page 28
- 31 Soft Pedal ..... page 14
- 32 Sostenuato Pedal (CVP-87A) ..... page 14
- 33 Damper Pedal ..... page 14
- 34 HEADPHONES Jacks ..... page 4
- 35 OPTIONAL IN R and L Jacks (CVP-87A & CVP-85A) ..... page 51
- 36 AUX OUT R and L/L+R Jacks (CVP-87A & CVP-85A) ..... page 51
- 37 EXP. PEDAL Jack (CVP-87A) ..... page 5, 51
- 38 MIDI Connectors ..... page 51



# Preparation

## ■ The Music Stand

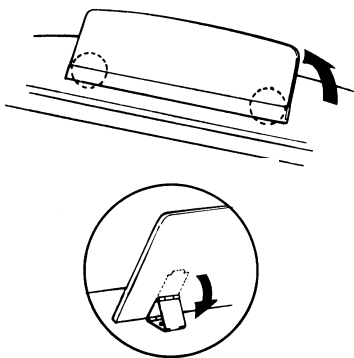

If you will be using sheet music with your Clavinova, raise the music stand built into it's top panel by lifting the rear edge of the music stand, flip the support brackets on the rear of the music stand down so that they fit into the corresponding recesses.

The music stand can be lowered after slightly lifting the stand and flipping the two brackets which support it upward.

## ■ The Key Cover (CVP-87A & CVP-85A)

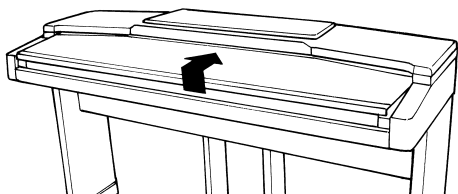

To open the CVP-87A or CVP-85A key cover lift it just enough to clear the keys (do not lift excessively) then slide the cover back into the main unit. To close the cover slide it forward all the way and then lower it gently until it closes completely.

## ■ The Power Switch



After making sure that the Clavinova's AC plug is properly inserted into a convenient AC wall outlet, press the **[POWER]** switch located to the left of the keyboard once to turn the power on. Press the **[POWER]** switch again to turn the power off.

When the power is initially turned on, the **PIANO** voice selector LED will light, the **POP 1** style selector LED will light, and "78" will appear on the **TEMPO** display.

## ■ Headphones

CVP-83S  
HEADPHONES



CVP-85A/87A  
HEADPHONES

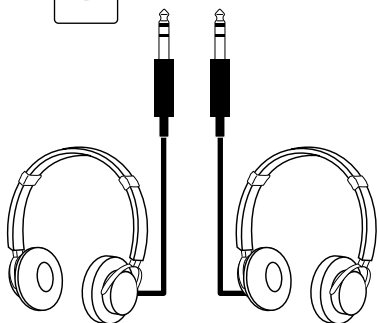

One or two standard pairs of stereo headphones can be plugged in here for private practice or late-night playing. The internal speaker system is automatically shut off when a pair of headphones is plugged into either or both of the **HEADPHONES** jacks.



The Clavinova has several volume controls that give you extra versatility in creating the required sound.

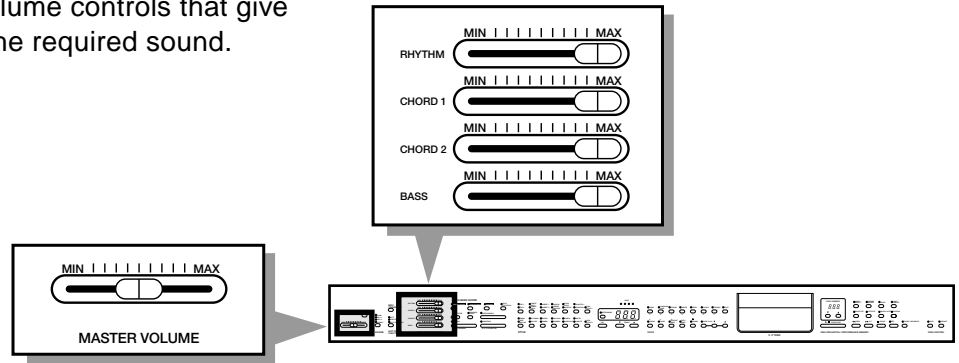

## ● Master Volume

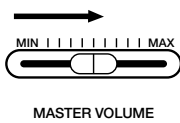

The **MASTER VOLUME** control adjusts the overall volume of sound produced by the Clavinova. It also adjusts headphone volume when one or two pairs of headphones are plugged into the **HEADPHONES** jacks.

Initially set the **MASTER VOLUME** control about half way between the “MIN” and “MAX” settings. Then, when you start playing, adjust the control for the most comfortable listening level.

## ● Auto Accompaniment

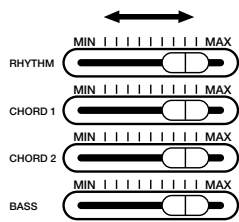

Separate volume controls are provided for the **RHYTHM**, **CHORD 1**, **CHORD 2**, and **BASS** sound. These volume controls let you set up the best balance between the various accompaniment parts when the **AUTO BASS CHORD (ABC)**, Disk Orchestra Collection playback, and Performance Memory features are used, and the **RHYTHM** volume control can be used to balance the keyboard and rhythm sound when only rhythm accompaniment is used.

The volume of the keyboard can be independently adjusted by using the **BASS** control while holding the [**MIDI/TRANPOSE**] button — this is particularly handy for adjusting the balance when recording the Clavinova sound.

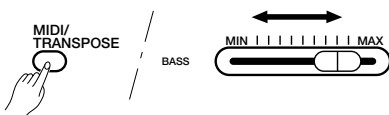

## ● Other Volume Control Modes

The Auto Accompaniment volume controls can be assigned to other functions via the “Accompaniment Volume Mode” utility function (page 42). They can be used to control modulation, pitch bend, and expression; or individual reverb depth for the rhythm, chord 1, chord 2, and bass parts.



- If any or all of the Auto Accompaniment volume controls are set to their minimum positions, no sound will be produced by the corresponding parts. The maximum control positions produce the normal volume levels.

## ● Expression Control (CVP-87A only)

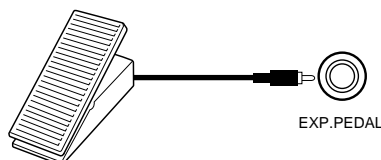

An optional Yamaha EP-1 Expression Pedal can be plugged into the CVP-87A **EXP. PEDAL** jack for foot volume (expression) control of the keyboard sound only (i.e. expression doesn't affect the auto-accompaniment sound or disk playback). Press the pedal forward to increase volume, and backward to decrease volume.

## The Internal Amplifier & Speaker System

The CVP-87A and CVP-85A feature a powerful stereo amplifier delivering 40 watts per channel while the CVP-83S has a high-performance 20-watt stereo amplifier. All three models include a high-performance speaker system that puts out exceptionally rich sound with natural response from powerful lows to shimmering highs. The CVP-87A and CVP-85A speaker systems employ two 13-centimeter speaker units for low-to-midrange reproduction, and two 5-centimeter speaker units for outstanding high-frequency sound. The CVP-83S has two 16-centimeter and two 5-centimeter units.

# Demonstration Playback

The Clavinova features 25 demonstration tunes that effectively demonstrate its sound and accompaniment capabilities. Here's how you can select and play the demo tunes.

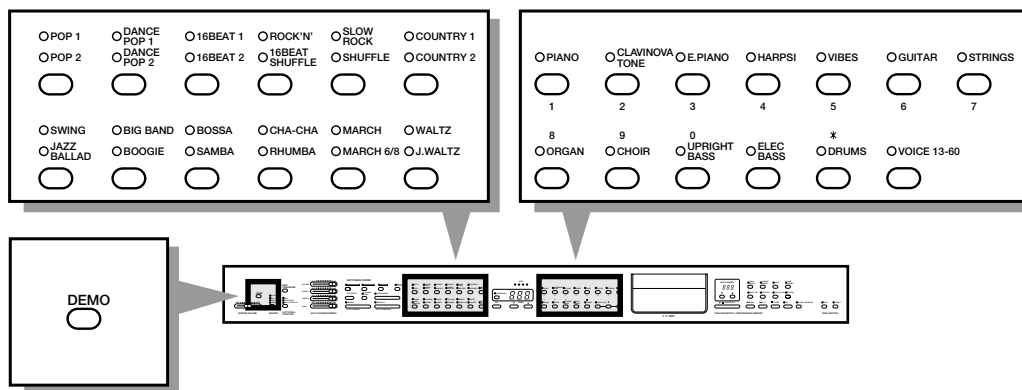

## 1 Press the [DEMO] button



## 2 Select a Demo Tune

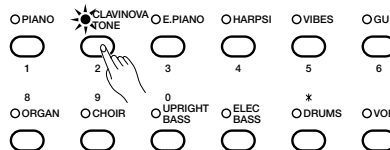

The 25 demo tunes are selected via the **STYLE** and **VOICE** selectors — the style and voice selectors will flash in sequence when the [DEMO] button is pressed. Press a selector to start playback of the corresponding tune. You can also select continuous repeat playback of all demo tunes by pressing the [START/STOP] button. The demo tunes will play back in sequential or random order, depending on the setting of the “Random All Song Repeat” utility function described on page 43.

## 3 Adjust the Volume

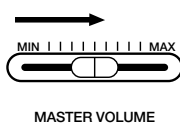

Use the **MASTER VOLUME** control to adjust the volume, and play along on the keyboard if you like.



• The tempo cannot be adjusted during demo playback.

## 4 Stop Playback

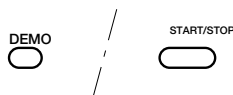

Demo playback can be stopped temporarily by pressing the [START/STOP] button. Press the [DEMO] button when you want to stop demo playback and return to the normal mode.

## The Demo Tunes

VOICE NAME	COMPOSER	SONG TITLE
PIANO	F. F. Chopin	Etude Op.25-1 “Aeolian Harp” or “The Shepherd Boy”
CLAVINOVA TONE	D. Foster	“Water Fountain” from “The Secret of My Success”
HARPSICHORD	J. S. Bach	Italienisches Konzert (Italian Concerto) BWV 971 3rd movement
GUITAR	I. Albeniz	Asturias
STRINGS	A. Vivaldi	The Four Seasons No. 3 “Autumn” 1st movement
ORGAN	J. S. Bach	Sinfonia from Kantate (Cantata) 29 BWV 29
CHOIR	W. A. Mozart	Requiem K. 626 No. 6 “Lacrimosa”

\* The demonstration pieces listed above are short excerpts from the original compositions. All other songs are original (© 1993 by Yamaha Corporation).

The CVP-87A, CVP-85A, and CVP-83S have a total of 60 different voices that can be selected in a number of ways. There's also a "Keyboard Percussion" mode that let's you play a range of drums and percussion instruments on the keyboard.

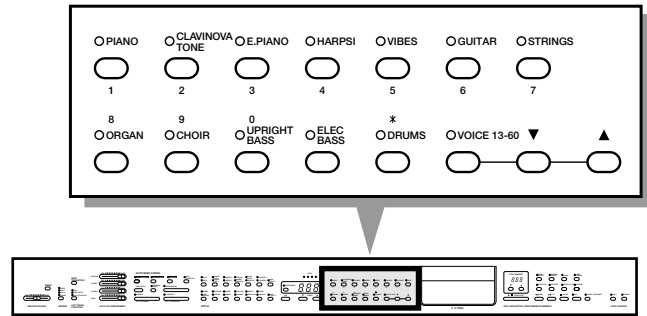

## Selecting the 60 Voices

### Voices 1-12: Direct Panel Selection

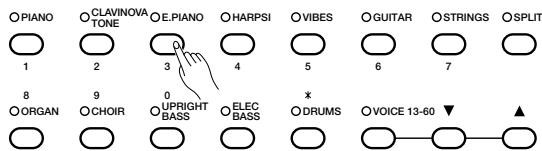

Of the Clavinova's 60 voices, 12 are "panel voices" which can be directly accessed by pressing the corresponding **VOICE** selector. When a voice selector is pressed the corresponding indicator will light and the number of the selected voice will appear on the **TEMPO** display while the voice selector is held.

The **PIANO** voice is automatically selected when the power is initially turned on.

### The VOICE 13-60 [▲] and [▼] Buttons

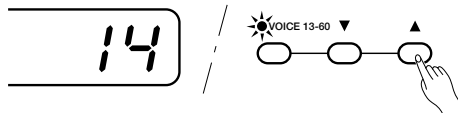

Use the [▲] and [▼] buttons immediately to the right of the [VOICE 13-60] button to select a voice number between 13 and 60. Press either button briefly to select the next voice number in the specified direction, or hold the button for continuous scrolling in the specified direction. The [VOICE 13-60] indicator will light and the voice number will appear on the **TEMPO** display during selection.

If a panel voice (1-12) is selected, the last selected voice in the 13-60 range can be instantly re-selected simply by pressing the [VOICE 13-60] button. The [VOICE 13-60] button will initially select voice number 13 (BRASS) after the power is turned on.



- Voice number 13 can be instantly selected by pressing the [▲] and [▼] buttons simultaneously.

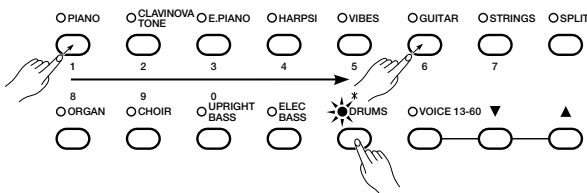

### Numeric Selection

Enter the number of the desired voice via the voice selectors (note that each voice selector has a number between 1 and 0 associated with it) while pressing the [DRUMS] selector.

To select voice number 16, for example, press and hold [DRUMS], press [PIANO/1], then [GUITAR/6], then release the [DRUMS] button. The voice number will appear on the **TEMPO** display while the [DRUMS] button is held. The [VOICE 13-60] button indicator will light whenever a voice number between 13 and 60 is selected.



## Panel Voices (1 — 12)

No.	Name	Usable Range
1	PIANO	A-1 - C7
2	CLAVINOVA TONE	C1 - C7
3	E. PIANO	C1 - C6
4	HARPSI	C1 - C6
5	VIBES	F2 - F5
6	GITAR	E1 - F#4
7	STRINGS	C0 - C6
8	ORGAN	C0 - C6
9	CHOIR	E1 - E5
10	UPRIGHT BASS	C0 - F#3
11	ELEC BASS	E0 - F#3
12	DRUMS	—

## Voices 13 — 60

No.	Name	Usable Range
13	BRASS	F0 - C6
14	POP BRASS	F0 - C6
15	TRUMPET	F0 - C6
16	MUTE TRUMPET	F#2 - A5
17	HORN	A#0 - F4
18	SAX	A#0 - F#5

No.	Name	Usable Range
19	SAX SOFT	A#0 - F#5
20	CLARINET	D2 - A#5
21	OBOE	A#2 - G5
22	FLUTE	G2 - F#6
23	ACCORDION	F2 - A5
24	HARMONICA	C3 - C6
25	STRINGS SOFT	C0 - C6
26	VIOLIN	C0 - C6
27	VIOLIN HARD	C0 - C6
28	FULL ORGAN	C0 - C6
29	JAZZ ORGAN 1	C1 - C6
30	SYNTH BRASS	C1 - C6
31	SYNTH WOOD	C2 - F#6
32	SYNTH STRINGS	C0 - C6
33	SYNTH CHOIR	E1 - E5
34	PIANO BRIGHT	A-1 - C7
35	PIANO SOFT	A-1 - C7
36	E. PIANO DX	C1 - C6
37	SYNTH CRYSTAL	C2 - C6
38	CELESTA	C2 - C6
39	MARIMBA	C2 - C6

No.	Name	Usable Range
40	FOLK GUITAR	E1 - A4
41	JAZZ GUITAR 1	E1 - A4
42	JAZZ GUITAR 2	E1 - A4
43	ROCK GUITAR 1	E1 - A4
44	ROCK GUITAR 2	E1 - A4
45	MUTE GUITAR	E1 - A4
46	BANJO	C3 - A5
47	PIZZICATO	C1 - C6
48	HARP	C1 - C6
49	U. BASS SOFT	C0 - F#3
50	E. BASS SOFT	E0 - F#3
51	E. BASS HEAVY	E0 - F#3
52	SYNTH BASS	E0 - F#3
53	TIMPANI & ORCH. HIT	E0 - C2/G2 - C6
54	BASSOON	A#0 - D4
55	CHAMBER STRINGS	C1 - C6
56	JAZZ ORGAN 2	C1 - C6
57	ROCK GUITAR 3	E1 - A4
58	COSMIC 1	G0 - C6
59	COSMIC 2	G0 - C6
60	COSMIC 3	G0 - C6



- When the **DRUMS** voice is selected only the keys with drum or percussion symbols printed above them will sound.
- The **PIANO** voice is automatically selected when the power is initially turned on.

## Keyboard Percussion



When the [**DRUMS**] voice selector is pressed (its indicator will light), you can play 44 different drum and percussion instruments on the keyboard. The percussion instruments played by the various keys are marked by symbols above the keys (keys with no symbols produce no sound).



- The **TRANPOSE** and **PITCH** functions described on pages 15 and 16 do not affect the **DRUMS** sound.

## Drum &amp; Percussion Key Assignments

Key	Instrument
A1	CYMBAL DAMP
F#2	BRUSH ROLL
G#2	HI-HAT CLOSED HEAVY
A#2	CRASH CYMBAL LIGHT
B2	BASS DRUM LIGHT
C3	SNARE DRUM + RIM HEAVY
C#3	RIDE CYMBAL CUP
D3	SNARE DRUM + RIM LIGHT
F3	BASS DRUM NORMAL
F#3	RIM SHOT
G3	SNARE DRUM HEAVY
G#3	BRUSH SHOT
A3	SNARE DRUM LIGHT
A#3	HI-HAT PEDAL
B3	SNARE DRUM ECHO
C4	TOM 4
C#4	HI-HAT CLOSED NORMAL

Key	Instrument
D4	TOM 3
D#4	HI-HAT OPEN
E4	TOM 2
F4	TOM 1
F#4	RIDE CYMBAL NORMAL
G4	ELECTRIC TOM 3
G#4	CRASH CYMBAL NORMAL
A4	ELECTRIC TOM 2
(A#4)	(CRASH CYMBAL)
B4	ELECTRIC TOM 1
C5	CONGA LOW
C#5	CABASA
D5	CONGA HIGH
D#5	METRONOME
E5	BONGO HIGH
F5	TIMBALE LOW

Key	Instrument
F#5	CLAVES
G5	TIMBALE HIGH
G#5	CASTANETS
A5	CUICA LOW
A#5	COWBELL
B5	CUICA HIGH
C6	HAND CLAP
C#6	AGOGO LOW
D#6	AGOGO HIGH
E6	BONGO LOW
(F6)	(CUICA LOW)
F#6	TAMBOURINE
(G6)	(CRASH CYMBAL)
G#6	TRIANGLE CLOSED
(A6)	(BRUSH ROLL)
A#6	TRIANGLE OPEN

- Cymbals (except G6) can be muted by pressing the A1 key.
- HI-HAT OPEN (D#4) is muted by HI-HAT CLOSED HEAVY (G#2), HI-HAT CLOSED NORMAL (C#4) and HI-HAT PEDAL (A#3).
- BRUSH ROLL (F#2) is muted by BRUSH SHOT (G#3).
- TRIANGLE OPEN (A#6) is muted by TRIANGLE CLOSED (G#6).
- The instruments listed in parentheses ( ) will not sound when played on the keyboard, but can be recorded using the Performance Memory (page 31) and will sound on playback. These instruments can also be played via MIDI.

The DUAL mode makes it possible to play two voices simultaneously across the entire range of the keyboard. This makes it easy to create exceptionally rich, thick tonal textures.

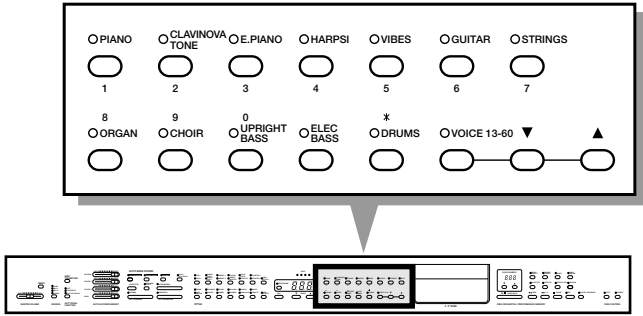

## Engaging the Dual Mode

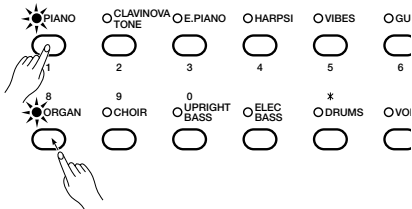

To engage the DUAL mode simply press two voice selectors at the same time — or press one voice selector while holding another. A voice in the 13...60 range can be “dualled” with the panel voices by pressing the [VOICE 13-60] button and any other voice selector at the same time (two voices in the 13...60 range cannot be combined). The [▲] and [▼] buttons can then be used to select the desired 13...60 voice. The higher voice number will appear on the TEMPO display during selection.

The voice indicators of both selected voices will light when the DUAL mode is active. To return to the normal single-voice play mode, press any single voice selector.

## Dual-mode Voice Balance

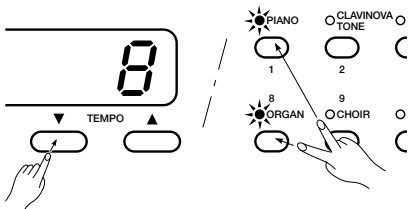

The volume balance between the two voices combined in the DUAL mode can be adjusted by using the TEMPO [▲] and [▼] buttons while pressing both of the active voice selectors. The selected balance value (1 ... 15) will be shown on the TEMPO display while the voice selectors and TEMPO [▲] or [▼] buttons are held.

- A setting of “1” sets the volume of the lowest-numbered voice to maximum and the highest-numbered voice to minimum (no sound).
- A setting of “8” sets both voices to the same volume (this is the default balance setting, and can be recalled by pressing the TEMPO [▲] and [▼] buttons simultaneously).
- A setting of “15” sets the volume of the highest-numbered voice to maximum and the lowest-numbered voice to minimum (no sound).

**NOTES**

- The TEMPO [▲] and [▼] buttons allow two-speed scrolling: press lightly to scroll through the values slowly, or press firmly to scroll rapidly.
- The dual mode cannot be used when the DRUMS voice is selected. Also, the dual and split modes cannot be used at the same time.



# Split Mode

The split mode lets you play different voices with the left and right hands — bass with the left and piano with the right, for example. You can assign any of the Clavinova's voices to the left and right-hand sections of the keyboard.

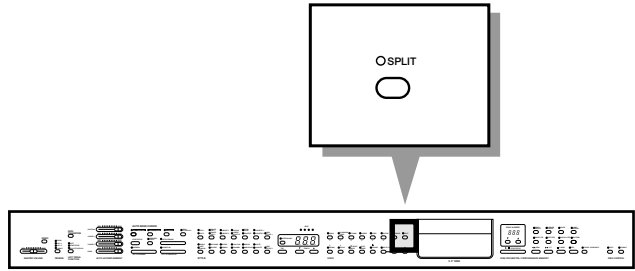

## Engaging the Split Mode

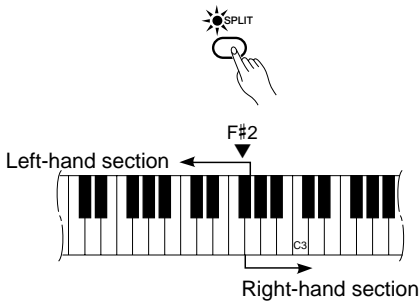

When the [SPLIT] button is pressed and its indicator lights, the keyboard is split into left- and right-hand sections and different voices can be assigned to each. The split point is initially set at the F#2 key when the power is turned on, and the UPRIGHT BASS voice is initially assigned to the left-hand section of the keyboard (all keys up to and including F#2). The voice that was selected when the SPLIT mode was engaged is assigned to the right-hand section of the keyboard. The current settings are retained if the SPLIT mode is turned off (press the [SPLIT] button again) and on while the power remains on.

## Changing the Split Voices

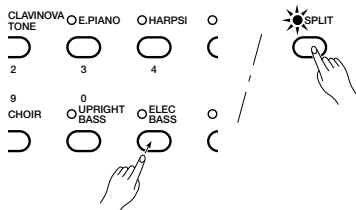

The right-hand voice can be changed simply by pressing the appropriate voice selector.

The left-hand voice can be changed by pressing a voice selector while holding the [SPLIT] button.



- All voices except BASS (voice numbers 10, 11, 49, 50, 51, and 52) and DRUMS (voice number 12) are shifted up one octave when assigned to the lower section of the keyboard (this function can be turned on or off via the "Octave Shift" utility function described on page 43).

## Changing the Split Point

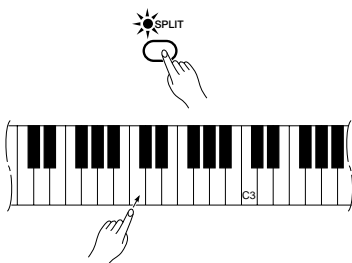

The split point can be set at any key by pressing the desired key while holding the [SPLIT] button. The split point key name will appear on the TEMPO display while the [SPLIT] button is held.

Example: A-1    A#-1    C2    C#2  
A-1    A#-1    C2    C#2

In the CVP-87A a keyboard guide lamp will indicate the selected split point. The default split point — F#2 — will always be set automatically whenever the power is initially turned on.



## Split Balance

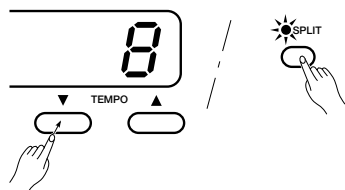

The volume balance between the left-hand and right-hand voices can be adjusted by using the **TEMPO** [▲] and [▼] buttons while holding the [SPLIT] button. The selected balance value (1 ... 15) will be shown on the TEMPO display while the [SPLIT] and **TEMPO** [▲] or [▼] buttons are held.

- A setting of “1” sets the volume of the left voice to maximum and the right voice to minimum (no sound).
- A setting of “8” sets both voices to the same volume (this is the default balance setting, and can be recalled by pressing the **TEMPO** [▲] and [▼] buttons simultaneously).
- A setting of “15” sets the volume of the right voice to maximum and the left voice to minimum (no sound).



NOTES

- The **TEMPO** [▲] and [▼] buttons allow two-speed scrolling: press lightly to scroll through the values slowly, or press firmly to scroll rapidly.

## Damper Pedal Operation in the Split Mode

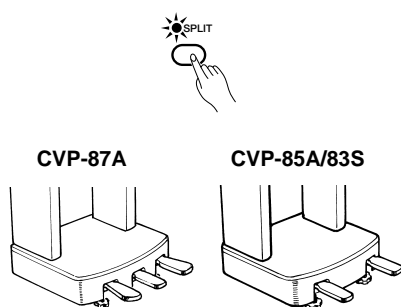

The damper pedal (the right pedal — see “The Pedals” on page 14) can be assigned to the left voice only, the right voice only, or to both voices in the split mode.

- **Right Voice Only (default):** Press the right (damper) pedal while holding the [SPLIT] button.
- **Left Voice Only:** Press the left (soft) pedal while holding the [SPLIT] button.
- **Both Voices:** Press both the right and left pedals while holding the [SPLIT] button.



NOTES

- The dual and split modes cannot be used at the same time.
- In the split the soft and sostenuto pedal functions apply to both the left- and right-hand voices.
- When the ABC Single Finger mode (page 20) and the split mode are used simultaneously, the left-hand voice will be accompanied by the appropriate ABC chord voices.

The [REVERB] button provides a number of digital effects that you can use for extra depth and expressive power.

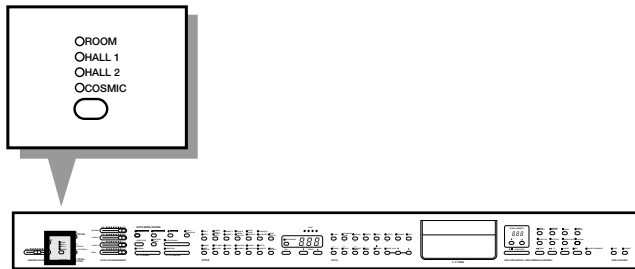

## Selecting a Reverb Effect

Each time the [REVERB] button is pressed the next effect on the reverb “list” is selected and the corresponding indicator will light. No effect is selected when no indicator is lit.



### OFF (No indicator lit)

No effect is produced.

### ROOM

This setting adds a reverb effect to the sound that is similar to the type of acoustic reverberation you would hear in a medium-size room.

### HALL 1

For a more spacious reverb sound, use the HALL 1 setting. This effect simulates the natural reverberation of a medium-size concert hall.

### HALL 2

HALL 2 simulates the reverb of a very large concert hall.

### COSMIC

“COSMIC” is an echo effect in which the sound seems to “bounce” around in the stereo sound field.

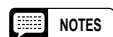

- The ROOM effect is automatically selected when the POWER switch is turned on.

## Reverb Depth Control

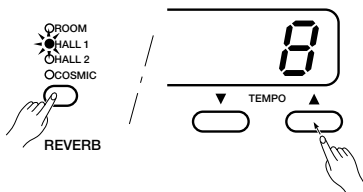

The depth of the selected reverb effect can be increased or decreased by pressing the TEMPO [▲] or [▼] button while holding the [REVERB] button. The reverb depth is shown on the TEMPO display while the [REVERB] and [▲] or [▼] buttons are held. The reverb depth range is from “0” (no effect) to “15” (maximum depth).



- Reverb depth is initially set to “8” when the power is turned on (this setting can be recalled during reverb depth selection by pressing the TEMPO [▲] and [▼] buttons simultaneously).
- The TEMPO [▲] and [▼] buttons allow two-speed scrolling: press lightly to scroll through the values slowly, or press firmly to scroll rapidly.





The Clavinova has “32-note polyphony” which means you can normally play up to 32 notes at once. This number varies, however, according to the functions being used, as shown in the chart below:

Keyboard only	32 notes.
Keyboard only (dual)	16 notes.
Keyboard + rhythm	24 notes (rhythm uses 8).
Keyboard (dual) + rhythm	12 notes
Keyboard + ABC	12 notes (rhythm 8; ABC 12).
Keyboard (dual) + ABC	6 notes

- The number of available notes is further reduced if the performance memory or a Disk Orchestra Collection disk is being played at the same time. Further variation occurs in the CVP-85A and CVP-83S with “1-layer” and “2-layer” voices: the polyphony is halved with 2-layer voices. The CVP-87A additionally features stereo voices. The following chart shows all stereo, 2-layer, and 1-layer voices in the CVP-87A, CVP-85A, and CVP-83S.

No.	Voice	CVP-87A	CVP-85A	CVP-83S	No.	Voice	CVP-87A	CVP-85A	CVP-83S
1	PIANO	2 (stereo)	1 (layer)	1 (layer)	31	SYNTH WOOD	1 (layer)	1 (layer)	2 (layer)
2	CLAVINOVA TONE	2 (layer)	1 (layer)	1 (layer)	32	SYNTH STRINGS	1 (layer)	1 (layer)	1 (layer)
3	E. PIANO	2 (velocity switch)	1 (layer)	1 (layer)	33	SYNTH CHOIR	1 (layer)	1 (layer)	1 (layer)
4	HARPSICHORD	1 (layer)	1 (layer)	1 (layer)	34	PIANO BRIGHT	2 (stereo)	1 (layer)	1 (layer)
5	VIBES	2 (detune)	1 (layer)	1 (layer)	35	PIANO SOFT	2 (stereo)	1 (layer)	1 (layer)
6	GIUITAR	1 (layer)	1 (layer)	1 (layer)	36	E. PIANO DX	2 (detune)	1 (layer)	1 (layer)
7	STRINGS	1 (layer)	1 (layer)	1 (layer)	37	SYNTH CRYSTAL	1 (layer)	1 (layer)	1 (layer)
8	ORGAN	2 (stereo)	1 (layer)	1 (layer)	38	CELESTA	1 (layer)	1 (layer)	1 (layer)
9	CHOIR	1 (layer)	1 (layer)	1 (layer)	39	MARIMBA	1 (layer)	1 (layer)	1 (layer)
10	UPRIGHT BASS	1 (layer)	1 (layer)	1 (layer)	40	FOLK GUITAR	1 (layer)	1 (layer)	1 (layer)
11	E. BASS	2 (velocity switch)	1 (layer)	1 (layer)	41	JAZZ GUITAR 1	1 (layer)	1 (layer)	1 (layer)
12	DRUMS	1 (layer)	1 (layer)	1 (layer)	42	JAZZ GUITAR 2	1 (layer)	1 (layer)	1 (layer)
13	BRASS	1 (layer)	1 (layer)	1 (layer)	43	ROCK GUITAR 1	1 (layer)	1 (layer)	1 (layer)
14	POP BRASS	1 (layer)	1 (layer)	1 (layer)	44	ROCK GUITAR 2	1 (layer)	1 (layer)	1 (layer)
15	TRUMPET	1 (layer)	1 (layer)	1 (layer)	45	MUTE GUITAR	1 (layer)	1 (layer)	1 (layer)
16	MUTE TRUMPET	1 (layer)	1 (layer)	1 (layer)	46	BANJO	1 (layer)	1 (layer)	1 (layer)
17	HORN	1 (layer)	1 (layer)	1 (layer)	47	PIZZICATO	1 (layer)	1 (layer)	1 (layer)
18	SAX	1 (layer)	1 (layer)	1 (layer)	48	HARP	1 (layer)	1 (layer)	1 (layer)
19	SAX SOFT	1 (layer)	1 (layer)	1 (layer)	49	U. BASS SOFT	1 (layer)	1 (layer)	1 (layer)
20	CLARINET	1 (layer)	1 (layer)	1 (layer)	50	E. BASS SOFT	1 (layer)	1 (layer)	1 (layer)
21	OBOE	1 (layer)	1 (layer)	1 (layer)	51	E. BASS HEAVY	1 (layer)	1 (layer)	1 (layer)
22	FLUTE	1 (layer)	1 (layer)	1 (layer)	52	SYNTH BASS	1 (layer)	1 (layer)	1 (layer)
23	ACCORDION	1 (layer)	1 (layer)	1 (layer)	53	TIMPANI & ORCH. HIT	1 (layer)	1 (layer)	1 (layer)
24	HARMONICA	1 (layer)	1 (layer)	1 (layer)	54	BASSOON	1 (layer)	1 (layer)	1 (layer)
25	STRINGS SOFT	1 (layer)	1 (layer)	1 (layer)	55	CHAMBER STRINGS	1 (layer)	1 (layer)	1 (layer)
26	VIOLIN	1 (layer)	1 (layer)	1 (layer)	56	JAZZ ORGAN 2	1 (layer)	2 (layer)	2 (layer)
27	VIOLIN HARD	1 (layer)	1 (layer)	1 (layer)	57	ROCK GUITAR 3	1 (layer)	1 (layer)	1 (layer)
28	FULL ORGAN	2 (stereo)	1 (layer)	1 (layer)	58	COSMIC 1	2 (layer)	2 (layer)	2 (layer)
29	JAZZ ORGAN 1	2 (detune)	1 (layer)	1 (layer)	59	COSMIC 2	1 (layer)	1 (layer)	1 (layer)
30	SYNTH BRASS	1 (layer)	1 (layer)	1 (layer)	60	COSMIC 3	2 (layer)	2 (layer)	2 (layer)

The Clavinova also offers keyboard touch response, so the volume and timbre of notes played can be controlled according to how “hard” you play the keys. The amount of variation available depends on the selected voice.



The CVP-83S and CVP-85A have two pedals while the CVP-87A has three. These offer a range of advanced expressive capabilities.

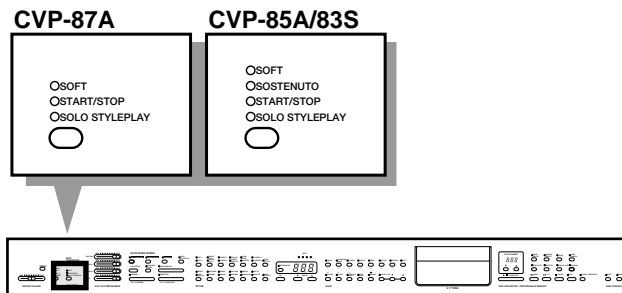
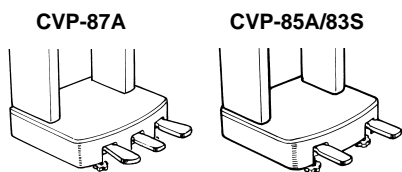

## Right Pedal (Damper Pedal)

The damper pedal functions in the same way as a damper pedal on an acoustic piano. When the damper pedal is pressed notes played have a long sustain. Releasing the pedal immediately stops (damps) any sustained notes.



- While the CVP-85A and CVP-83S damper pedals are either on or off, the CVP-87A damper pedal offers continuous damping control. On/off operation can also be selected via the “Damper Pedal Mode” utility function (page 43).

## Center Pedal (Sostenuto Pedal, CVP-87A only)

If you play a note or chord on the keyboard and press the sostenuto pedal while the note(s) are held, those notes will be sustained as long as the pedal is held (as if the damper pedal had been pressed) but all subsequently played notes will not be sustained. This makes it possible to sustain a chord, for example, while other notes are played “staccato.”

## Left Pedal (Multi-function)

CVP-83S/85A

- SOFT
- OSOSTENUTO
- OSTART/STOP
- OSOLO STYLEPLAY

LEFT PEDAL FUNCTION

CVP-87A

- SOFT
- OSTART/STOP
- OSOLO STYLEPLAY

LEFT PEDAL FUNCTION

The left pedal has a number of functions which can be selected using the [LEFT PEDAL FUNCTION] button and indicators. Each time the [LEFT PEDAL FUNCTION] button is pressed the next function on the LEFT PEDAL function “list” is selected and the corresponding indicator will light.

### ● Soft

Pressing the soft pedal subtly reduces the volume and slightly changes the timbre of notes played. The **SOFT** function is automatically selected whenever the **POWER** switch is turned on.

### ● Sostenuto (CVP-85A and CVP-83S)

If you play a note or chord on the keyboard and press the sostenuto pedal while the note(s) are held, those notes will be sustained as long as the pedal is held (as if the damper pedal had been pressed) but all subsequently played notes will not be sustained. This makes it possible to sustain a chord, for example, while other notes are played “staccato.”

The left-pedal **SOSTENUTO** function cannot be selected while the **SOLO STYLEPLAY** feature is operating.

### ● Start/Stop

The left pedal performs the same function as the panel [START/STOP] buttons. For details on the **START/STOP** function, refer to the “Accompaniment” section on page 18, 19.

### ● Solo Styleplay

For details on the **SOLO STYLEPLAY** function see “SOLO STYLEPLAY” on page 25 (the **SOLO STYLEPLAY** pedal function can only be selected when the **SOLO STYLEPLAY** feature is in use).



- The damper, soft, and sostenuto pedal functions do not affect the **DRUMS** voice.



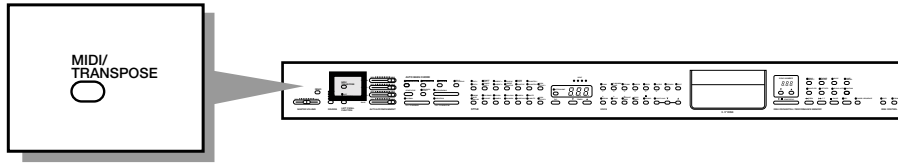

The pan settings are as follows:

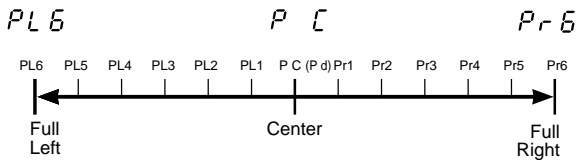

- The pan (stereo) position of the voice played on the keyboard can be adjusted by moving the **RHYTHM** volume control while holding the [MIDI/TRANSPOSE] button. The pan position is shown on the **TEMPO** display, from “P L 6” for full left at the “MIN” control position, through “P C” for center, to “P r 6” for full right at the “MAX” control position. This can be used to produce a broader ensemble sound with the Performance Memory multitrack recording feature.

Each voice has a preset pan setting (indicated by “P d” on the **TEMPO** display) which is automatically set when the power is first turned on.

**NOTES**

- The “P d” keyboard scale pan default for some voices places the treble-register sound to the right and the bass-register sound to the left. Using a different PAN setting places the entire voice, low and high notes included, at the same position.
- The **DRUMS** voice has a preset PAN setting which cannot be changed.

# Transposition

The Clavinova’s **TRANSPOSE** function makes it possible to shift the pitch of the entire keyboard up or down in semitone intervals up to a maximum of six semitones. “Transposing” the pitch of the Clavinova keyboard makes it easier to play in difficult key signatures, and you can simply match the pitch of the keyboard to the range of a singer or other instrumentalist.

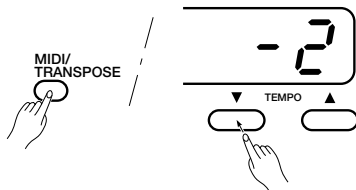
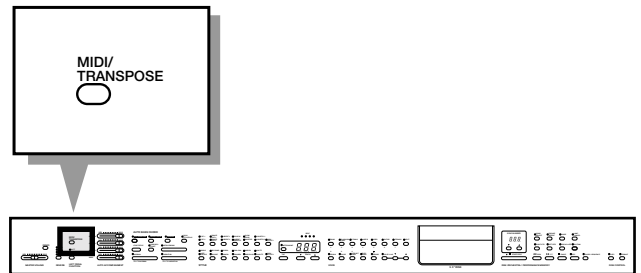

- Use the **TEMPO** [▲] and [▼] buttons to select the desired degree of transposition while holding the [MIDI/TRANSPOSE] button. The amount of transposition selected is shown on the **TEMPO** display as follows:

Display	Transposition	Display	Transposition
-6	-6 semitones	0	Normal
-5	-5 semitones	1	+1 semitone
-4	-4 semitones	2	+2 semitones
-3	-3 semitones	3	+3 semitones
-2	-2 semitones	4	+4 semitones
-1	-1 semitone	5	+5 semitones
0	Normal	6	+6 semitones

**NOTES**

- Press the [▲] and [▼] buttons simultaneously while holding the [MIDI/TRANSPOSE] button to restore normal keyboard pitch.
- Transpose is always set to Normal when the power is turned on.
- The **TRANSPOSE** function does not affect the **DRUMS** sound.
- The **TEMPO** [▲] and [▼] buttons allow two-speed scrolling: press lightly to scroll through the values slowly, or press firmly to scroll rapidly.
- Notes below and above the original 88-key range of the Clavinova sound one octave higher and lower, respectively.

Pitch control makes it possible to tune the Clavinova over a  $\pm 50$ -cent range (approximate) in approximately 1.2-cent or 1-hertz intervals. A hundred “cents” equals one semitone, so the tuning range provided allows fine tuning of overall pitch over a range of approximately a semitone. Pitch control is useful for tuning the Clavinova to match other instruments or recorded music.

## ● Tuning Up .....

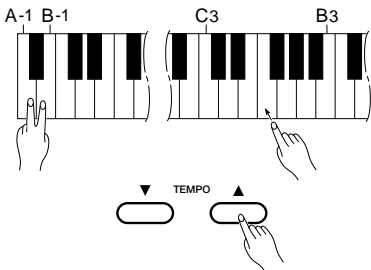

**1** To tune up (raise pitch), hold the **A-1** and **B-1** keys simultaneously (A-1 and B-1 are the two lowest white keys on the keyboard) and press any key between **C3** and **B3**. Each time a key in this range is pressed the pitch is raised by approximately 1.2 cents, up to a maximum of about 50 cents above standard pitch. To raise the pitch in 1-hertz increments press the **TEMPO [▲]** button instead of the **C3-B3** keys. The **TEMPO [▼]** button can also be used to tune down while the **A-1** and **B-1** keys are held.

**2** Release the **A-1** and **B-1** keys.

## ● Tuning Down .....

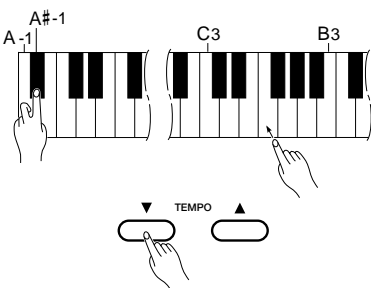

**1** To tune down (lower pitch), hold the **A-1** and **A#-1** keys simultaneously and press any key between **C3** and **B3**. Each time a key in this range is pressed the pitch is lowered by approximately 1.2 cents, up to a maximum of about 50 cents below standard pitch. To lower the pitch in 1-hertz increments press the **TEMPO [▼]** button instead of the **C3-B3** keys. The **TEMPO [▲]** button can also be used to tune up while the **A-1** and **A#-1** keys are held.

**2** Release the **A-1** and **A#-1** keys.

## ● To Restore Standard Pitch\*

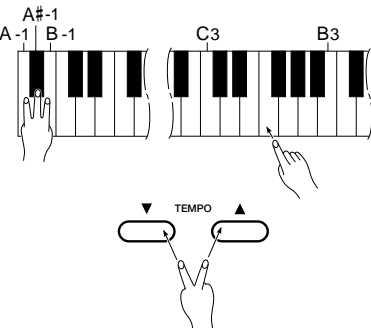

**1** To restore standard pitch (A3 = 440 Hz), hold the **A-1**, **A#-1**, and **B-1** keys simultaneously and press any key between **C3** and **B3**, or simultaneously press the **TEMPO [▲]** and **[▼]** buttons.

**2** Release the **A-1**, **A#-1**, and **B-1** keys.

\* Standard pitch (A3 = 440 Hz) is automatically set whenever the **POWER** switch is initially turned on.



- The **PITCH** function does not affect the **DRUMS** sound.
- The **TEMPO [▲]** and **[▼]** buttons allow two-speed scrolling: press lightly to scroll through the values slowly, or press firmly to scroll rapidly.

## ■ The Pitch Display

Example:

442 442.0 ..... 442.24  
 4.42 442.25 ..... 442.49  
 44.2 442.5 ..... 442.74  
 442. 442.75 ..... 442.99

The approximate pitch of A3 is shown on the TEMPO display in Hertz while the pitch control function is in operation. The total display range is from approximately 427 hertz (-50 cents) to 453 hertz (+50 cents).

The dots to the right of each figure in the display are used to provide a general idea of fractional pitches.

The CVP-87A, CVP-85A, and CVP-83S have 24 “styles” that can be used as a basis for rhythm accompaniment, or fully orchestrated rhythm, bass, and chord accompaniment (see “Auto Bass Chord” on page 20).



• The Accompaniment Style data is not transmitted via the MIDI OUT connector.

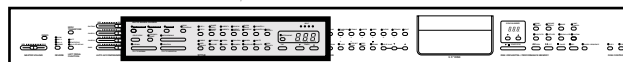
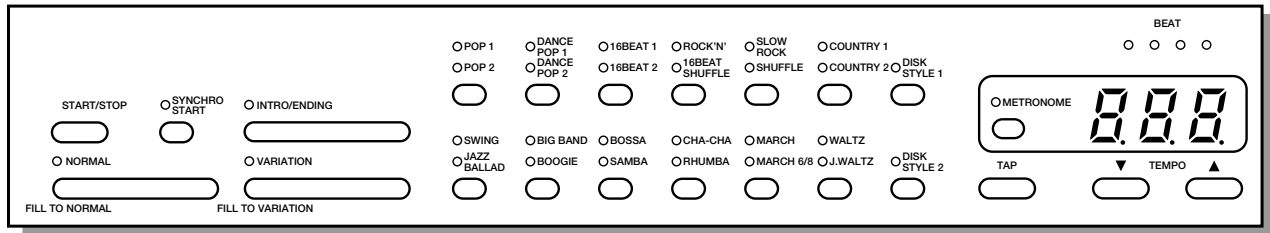

## Style Selection

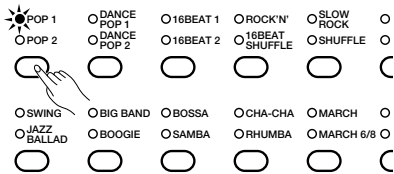

The 24 styles are selected using 12 **STYLE** selectors. Note that each style selector has two indicators and style names above it. These two styles are selected alternately each time the selector is pressed.

The **POP 1** style is automatically selected when the power is initially turned on.



- There are also two [DISK STYLE] buttons that can be used to select styles loaded from floppy disk (the supplied Style Disk). See the “Disk Styles” section on page 23 for details.
- Use the RHYTHM volume control to adjust the volume of the rhythm sound.

## Tempo Control

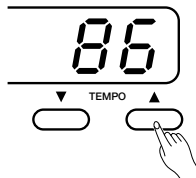

Whenever you select a different style, the “suggested” tempo for that style is also selected, and the tempo is displayed on the **TEMPO** display in quarter-note beats per minute (unless the accompaniment is playing, in which case the same tempo is maintained).

You can change the tempo to any value between 32 and 280 beats per minute, however, by using the **TEMPO** [▲] and [▼] buttons. This can be done either before the accompaniment is started or while it is playing. Press either button briefly to decrement or increment the tempo value by one, or hold the button for continuous decrementing or incrementing. Press lightly for slow, or harder for fast decrementing or incrementing.



- The suggested tempo for the selected style can be recalled at any time by pressing both the [▲] and [▼] buttons simultaneously.

### Suggested Tempos

Style	Suggested Tempo	Style	Suggested Tempo
POP 1	78	SWING	160
POP 2	98	JAZZ BALLAD	80
DANCE POP 1	138	BIG BAND	152
DANCE POP 2	94	BOOGIE	160
16BEAT 1	78	BOSSA	132
16BEAT 2	98	SAMBA	112
ROCK'N'	160	CHA-CHA	132
16BEAT SHUFFLE	90	RHUMBA	112
SLOW ROCK	72	MARCH	120
SHUFFLE	144	MARCH 6/8	116
COUNTRY 1	184	WALTZ	90
COUNTRY 2	138	J.WALTZ	160

## Starting the Accompaniment

There are several ways to start the accompaniment:

### ● Straight Start



Press the **[START/STOP]** button.

Each of the styles also has a variation that can be selected by pressing the **[VARIATION/FILL TO VARIATION]** button (its LED will light) before pressing the **[START/STOP]** button. Normally the **[NORMAL/FILL TO NORMAL]** button LED will be lit (or you can select it if the variation is selected), indicating that the normal pattern is selected.

Normal straight start = **[NORMAL/FILL TO NORMAL]** → **[START/STOP]**

Variation straight start = **[VARIATION/FILL TO VARIATION]** → **[START/STOP]**

### ● Start With an Introduction

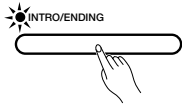

Press the **[INTRO/ENDING]** button.

If you press the **[NORMAL/FILL TO NORMAL]** or **[VARIATION/FILL TO VARIATION]** button while holding the **[INTRO/ENDING]** button, the rhythm will start with an appropriate fill and then go to the normal rhythm or variation rhythm, respectively.

Intro start =  (Flashing) **[INTRO/ENDING]** → **[START/STOP]**

Fill start to normal = **[INTRO/ENDING]** +  (Flashing) **[NORMAL/FILL TO NORMAL]** → **[START/STOP]**

Fill start to variation = **[INTRO/ENDING]** +  (Flashing) **[VARIATION/FILL TO VARIATION]** → **[START/STOP]**

The selected start mode can be disengaged prior to starting the accompaniment by pressing the selected button (flashing indicator) a second time.

### ● Synchronized Start



Any of the start types described above can be synchronized to the first note or chord played on the keyboard by first pressing the **[SYNCHRO START]** button so that its indicator lights. When the keyboard is split or Auto Bass Chord Single Finger or Fingering mode is used, the first note played on the left-hand section of the keyboard will start the accompaniment (i.e. keys to the left of and including the split-point key — normally F#2). Once the synchronized start mode has been selected, use the **[NORMAL/FILL TO NORMAL]**, **[VARIATION/FILL TO VARIATION]** and/or **[INTRO/ENDING]** buttons to select the type of start you want.

The first dot of the BEAT display will flash at the current tempo when a synchronized start mode has been selected.

After pressing **[SYNCHRO START]**

Normal start = **[NORMAL/FILL TO NORMAL]** → Play key

Variation start = **[VARIATION/FILL TO VARIATION]** → Play key

Intro start = **[INTRO/ENDING]** → Play key

Fill start to normal = **[INTRO/ENDING]** + **[NORMAL/FILL TO NORMAL]** → Play key

Fill start to variation = **[INTRO/ENDING]** + **[VARIATION/FILL TO VARIATION]** → Play key

The synchronized start mode can be cancelled by pressing the **[SYNCHRO START]** button a second time so that its indicator goes out.



• The synchronized start mode is automatically turned on when one of the ABC modes is engaged — see page 20 for details.



● Tap start

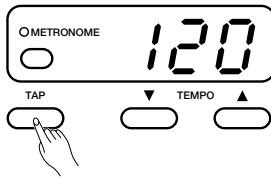

This function lets you set the tempo and start the rhythm in one operation. Simply tap the [TAP] button at the required tempo — 3 times for a 3/4 style and 4 times for a 4/4 style. The rhythm will start from the beginning of the next measure at the specified tempo.



- The [TAP] button can also be used to change the tempo during rhythm playback. In this case the “tap” click will not sound.
- If you tap the [TAP] button less than the required number of times (i.e. 3 or 4), the tap tempo function will be cancelled after a few seconds.

● Measure Number

During rhythm playback the current measure number is shown on the TEMPO display.

● The Beat Display

The four LED dots of the **BEAT** display provide a visual indication of the selected tempo. The leftmost (red) dot flashes on the first beat of each measure, the second dot flashes on the second beat, and so on (all dots except the leftmost dot are green). When a 3/4-time rhythm is selected, only the first three dots will flash.

	BEAT			
1st. Beat	●	○	○	○
2nd. Beat	○	●	○	○
3rd. Beat	○	○	●	○
4th. Beat	○	○	○	●

■ Fill-ins

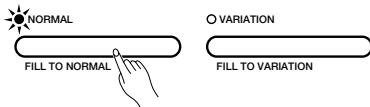

The CVP-87A, CVP-85A and CVP-83S provide two types of automatic “fill-ins.”

- **Fill To Normal:** Press the [NORMAL/FILL TO NORMAL] button during playback to produce a fill-in and go to the normal rhythm.
- **Fill To Variation:** Press the [VARIATION/FILL TO VARIATION] button during playback to produce a fill-in and go to the variation pattern.

If you hold one of the **FILL** buttons, the fill-in will repeat until the end of the measure in which button is released.

■ Stopping the Accompaniment

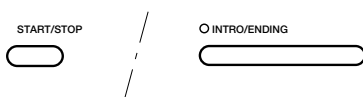

The accompaniment can be stopped at any time by pressing the [START/STOP] button. Press the [INTRO/ENDING] button if you want to go to the ending pattern and then stop.



- If you started with an intro or fill-in, or using the SYNCHRO mode, these selections are maintained even after the accompaniment is stopped.
- If the left pedal is switched to START/STOP operation, it performs the same function as the panel [START/STOP] buttons (press to START, press again to STOP).

■ Metronome

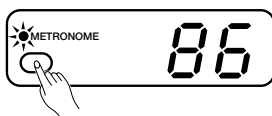

The CVP-87A, CVP-85A, and CVP-83S also offer a metronome function that is ideal for practice.

To start the metronome, simply press the [METRONOME] button so that its indicator lights. The metronome will play at the currently selected tempo whether a style is playing or not. The metronome volume can be adjusted via the **RHYTHM** volume control.

Press the [METRONOME] button again to stop the metronome sound (the **METRONOME** indicator will go out). The metronome will also stop automatically if the [START/STOP] button is pressed to stop a style in progress.



- The metronome will not normally sound when a style is playing. If the style is started by pressing the [START/STOP] button while the metronome is playing, however, the metronome will continue to sound along with the style.



# Auto Bass Chord (ABC)

The CVP-87A, CVP-85A, and CVP-83S include a sophisticated auto-accompaniment system (Auto Bass Chord — ABC) that can provide automated rhythm, bass and chord backing in a number of ways.

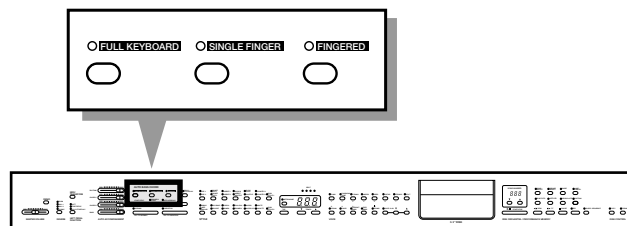

## Single-finger Accompaniment

**SINGLE FINGER** accompaniment makes it simple to produce accompaniment using major, seventh, minor and minor-seventh chords by pressing a minimum number of keys in the ABC section of the keyboard. The automatic accompaniment consists of rhythm, bass and chords.

### 1 Select SINGLE FINGER



Press the [**SINGLE FINGER**] button to select the **SINGLE FINGER** mode (the **SINGLE FINGER** indicator will light).

### 2 Select a Style

Select the desired accompaniment using the style selectors (see “Style Selection” on page 17).

### 3 Set the Tempo

Use the **TEMPO** [**▲**] and [**▼**] buttons to set the desired accompaniment tempo if necessary (see “Tempo Control” on page 17).

### 4 Play

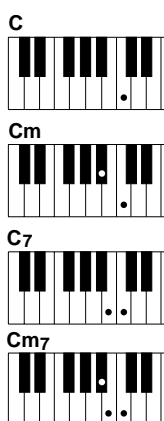

Pressing any key on the ABC section of the keyboard (up to the split point — normally the F#2 key) will cause the automatic chord and bass accompaniment to begin (synchro start is automatically selected in the ABC mode). If you press a “C” key, for example, a C-major accompaniment will be played. Press another key in the ABC section of the keyboard to select a new chord. The key you press will always determine the “root” of the chord played (i.e. “C” for a C chord).



• Automatic synchro start switching can be enabled or disabled via the utility 1 mode “Auto Synchro Start Switching” function, described on page 43.

#### ● Playing Minor, Seventh, and Minor-seventh Chords in the Single-finger Mode

- For a minor chord, press the root key and a black key to its left.
- For a seventh chord, press the root key and a white key to its left.
- For a minor-seventh chord, press the root key and both a white and black key to its left.

### 5 Stop the Accompaniment

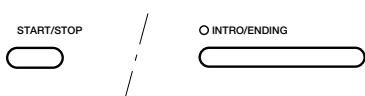

Press the [**START/STOP**] or [**INTRO/ENDING**] button to stop the accompaniment.



• Press the [**SINGLE FINGER**] button so that its indicator goes out when you want to exit from the **SINGLE FINGER** mode.



## ■ Fingered Accompaniment

The **FINGERED** mode is ideal if you already know how to play chords on a keyboard, since it allows you to supply your own chords for the Auto Accompaniment feature.

### 1 Select FINGERED



Press the **[FINGERED]** button to select the **FINGERED** mode (the **FINGERED** indicator will light).

### 2 Select a Style

Select an accompaniment style using the style selectors (see “Style Selection” on page 17).

### 3 Set the Tempo

Use the **TEMPO** [**▲**] and [**▼**] buttons to set the desired accompaniment tempo if necessary (see “Tempo Control” on page 17 for more details).

### 4 Play

As soon as you play any chord (up to 4 notes) on the lower keyboard (up to the split point — normally the F#2 key), the Clavinova will automatically begin to play the chord along with the selected rhythm and an appropriate bass line (synchro start is automatically selected in the ABC mode\*).

\* Automatic synchro start switching can be enabled or disabled via the utility 1 mode “Auto Synchro Start Switching” function, described on page 43.

#### The Clavinova will accept the following chord 20 types:

- Major [M]
- Minor [m]
- Major seventh [M7]
- Sixth [6]
- Seventh [7]
- Minor sixth [m6]
- Minor seventh [m7]
- Minor major seventh [mM7]
- Minor seventh flatted fifth [m7-5]
- Minor flatted fifth [m-5]
- Major flatted fifth [M-5]
- Seventh flatted fifth [7-5]
- Major seventh flatted fifth [M7-5]
- Seventh suspended fourth [7sus4]
- Suspended fourth [sus4]
- Augmented [aug]
- Seventh sharp fifth [7+5]
- Major seventh sharp fifth [M7+5]
- Diminished [dim]
- Half diminished (minor major seventh flatted fifth) [mM7-5]



• The automatic accompaniment will sometimes not change when related chords are played in sequence (e.g. some minor chords followed by the minor seventh).

- The **[INTRO/ENDING]**, **[NORMAL/FILL TO NORMAL]**, and **[VARIATION/FILL TO VARIATION]** buttons can be used in the ABC mode to create pattern variations in the same way that they are used with rhythm patterns (refer to the “Accompaniment” section on page 18, 19 for details).

- Normal start = **[NORMAL/FILL TO NORMAL]** → Lower key
- Variation start = **[VARIATION/FILL TO VARIATION]** → Lower key
- Intro start = **[INTRO/ENDING]** → Lower key
- Fill start to normal = **[INTRO/ENDING]** + **[NORMAL/FILL TO NORMAL]** → Lower key
- Fill start to variation = **[INTRO/ENDING]** + **[VARIATION/FILL TO VARIATION]** → Lower key

### 5 Stop the Accompaniment

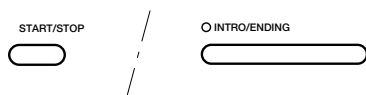

Press the **[START/STOP]** or **[INTRO/ENDING]** button to stop the accompaniment.



• Press the **[FINGERED]** button so that its indicator goes out when you want to exit from the **FINGERED** mode.



## Full-keyboard ABC

### ● Full-keyboard ABC



When this advanced auto-accompaniment mode is engaged (press the **[FULL KEYBOARD]** button so that its indicator lights) the Clavinova will automatically create appropriate accompaniment while you play just about anything, anywhere on the keyboard: chords, a bass line, arpeggiated chords, a melody line. You don't have to worry about specifying the accompaniment chords. Although Full-keyboard ABC is designed to work with many songs, some arrangements may not be suitable for use with this feature. Try playing a few simple songs in the Full-keyboard ABC mode to get a feel for its capabilities.



- Chord detection occurs at approximately 8th-note intervals. Extremely short chords — less than an 8th note in length — may therefore not be detected.

### ● Conventional Full-keyboard ABC

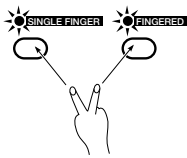

The Conventional Full-keyboard ABC mode can be engaged by pressing the **[SINGLE FINGER]** and **[FINGERED]** buttons simultaneously (both indicators will light). In this mode the split point is de-activated and notes played anywhere on the keyboard are detected and used to determine the harmonization of the accompaniment. In the Conventional Full-keyboard ABC mode, chord detection is possible when at least three notes are played anywhere on the keyboard.



- The Dual or SPLIT mode can be used with Full-keyboard ABC.
- The Full-keyboard and Conventional Full-keyboard ABC modes will be disengaged and the Fingered mode will be engaged if Solo Styleplay is turned on.
- Solo Styleplay will automatically be turned off whenever the Full-keyboard or Conventional Full-keyboard ABC mode is engaged.
- Press the **[FULL KEYBOARD]** button so that its indicator goes out when you want to exit from the FULL-KEYBOARD ABC mode. To exit from the Conventional Full-keyboard ABC mode press the **[SINGLE FINGER]** or **[FINGERED]** button twice.

## Volume Control

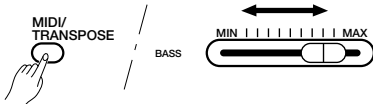
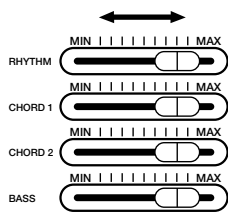

The **RHYTHM**, **CHORD 1**, **CHORD 2**, and **BASS** volume controls can be used to adjust the volume of the corresponding accompaniment parts when using ABC. In general, **CHORD 1** controls rhythmic chords while **CHORD 2** controls more decorative chords (arpeggios, etc.). The volume of the keyboard can be independently controlled by using the **BASS** volume control while holding the **[MIDI/TRANPOSE]** button.



- Some styles may not use all four parts: RHYTHM, CHORD 1, CHORD 2, and BASS.
- Usually the CHORD 1 and CHORD 2 parts will not play simultaneously in the Full-keyboard ABC mode to prevent possible conflict with the melody. The sound of the silent part can be restored by changing the setting of the corresponding volume control — CHORD 1 or CHORD 2.

## Changing the ABC Split Point

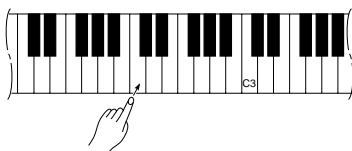

The ABC split point can be set at any key by pressing the desired key while holding the **[SINGLE FINGER]** or **[FINGERED]** button.

The default split point — F#2 — will always be set automatically whenever the power is initially turned on.



- On the CVP-87A the split point is indicated by the keyboard guide lamp above the split point key.

## Special Modes

### ● Mute

Some accompaniment notes may be automatically muted if they interfere musically with what is being played by the right hand. This mute function can be enabled or disabled via the Utility mode “Mute” function described on page 43. The mute function is normally enabled (default).

### ● Minor Harmonization

When playing a 7th chord in a minor key, the ABC system will automatically shift a 9th note down to the octave, and a 6th note to the 5th when the “Minor Harmonization” utility function described on page 43 is turned on. The default setting for this function is off.



- Minor Harmonization will not function in the Full-keyboard ABC mode.

A “Style Disk” is supplied with the Clavinova, providing an extra 40 ABC accompaniment styles. Any two of these patterns can be loaded into the Clavinova’s memory at a time. The [DISK STYLE 1] and [DISK STYLE 2] buttons select the loaded disk styles in the same way as the STYLE selectors select the internal styles.

**NOTES**

- If no disk styles are loaded as described below, the [DISK STYLE 1] and [DISK STYLE 2] buttons select pre-programmed disk styles contained in internal ROM memory. These are the default styles selected by the [DISK STYLE 1] and [DISK STYLE 2] buttons whenever the power is initially turned on.

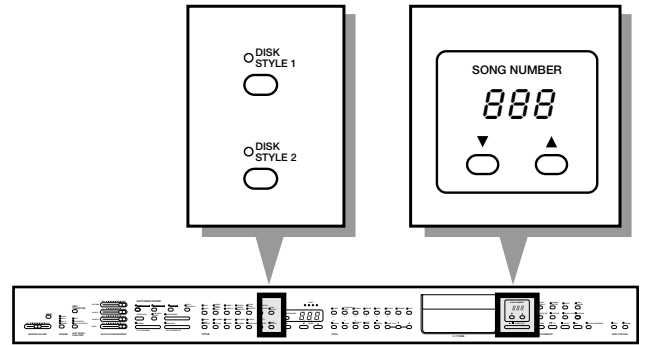

## Selecting & Loading Disk Styles

### 1 Insert the Style Disk

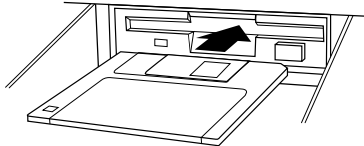

Insert the Style Disk into the disk drive with the sliding door on the disk facing the drive slot and the label side facing upward. The disk should click into place and the disk lamp will light briefly while the Clavinova reads and identifies the disk.

### 2 Make Sure the [SONG SELECT] Indicator Is Lit



The [SONG SELECT] indicator will light automatically when the disk is ready. If a disk is already loaded and the [SONG SELECT] indicator is not lit, press the [SONG SELECT] button so that it lights. When this is done the [DISK STYLE 1] and [DISK STYLE 2] button indicators will flash alternately, and the single-finger ABC mode and synchronized start mode will be engaged (any other ABC mode will remain active if it was selected before the disk was loaded).

### 3 Select a Style

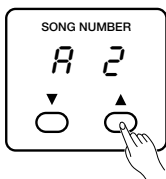

Use the [▲] and [▼] buttons below the SONG NUMBER display to select the desired style number. The selected style number will appear on the SONG NUMBER display — “A 1” for example. You can “preview” the selected style by playing on the left-hand section of the keyboard (single-finger or fingered). Pattern playback will stop if a different pattern number is selected.

**NOTES**

- If a tempo is set prior to loading the style, that tempo becomes the default for the loaded style.

### 4 Load the Style



Press the [DISK STYLE 1] or [DISK STYLE 2] button to load the selected pattern into that button. The [DISK STYLE 1] or [DISK STYLE 2] indicator will light, and the [SONG SELECT] indicator will go out.

### 5 Repeat

Repeat steps 2 through 4 to select and load a second pattern into the other [DISK STYLE] button if you like.

### 6 Eject the Disk When Done

When you’ve finished with the Style Disk, press the disk drive EJECT button to remove it.



Disk Style List

Group	No.	Name
ROCK & POP	1	ROCK'N' ROLL
	2	ROCKABILLY
	3	R&R SHUFFLE
	4	60'S ROCK
	5	RHYTHM & BLUES
	6	GOSPEL
	7	GOSPEL BALLAD
	8	8 BEAT POP
	9	ROCK BALLAD
	10	BIG BALLAD
	11	SOUL ROCK
	12	16 BEAT BALLAD
	13	16 BEAT POP
	14	16 BEAT DISCO
	15	HOUSE POP
	16	TECHNO POP
JAZZ	17	BEBOP
	18	BOOGIE
	19	STRIDE PIANO
	20	DIXIELAND
	21	RAGTIME

Group	No.	Name
LATIN	22	BOSSA NOVA
	23	POP BOSSA
	24	SAMBA
	25	BIGBAND CHA-CHA
	26	TANGO
	27	MAMBO
	28	LATIN POP
	29	BROADWAY
STANDARD	30	FOXTROT
	31	SLOW FOX
	32	WALTZ
WALTZ	33	VIENNESE WALTZ
	34	CHANSON
	35	SWING WALTZ
WORLD	36	BLUEGRASS
	37	COUNTRY SHUFFLE
	38	SEVILLIANAS
	39	POLKA
	40	REGGAE

Using a Loaded Disk Style

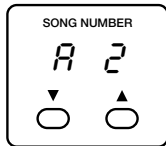

After you've loaded the desired Disk Styles, the [DISK STYLE 1] and [DISK STYLE 2] buttons can be used in exactly the same way as the other STYLE buttons to select the loaded patterns for ABC accompaniment (see "Auto Bass Chord (ABC)" beginning on page 20).

The number of the Disk Style selected by the [DISK STYLE 1] or [DISK STYLE 2] button will be shown on the SONG NUMBER display.



This sophisticated feature not only provides automatic rhythm, bass and chord accompaniment, but it also adds appropriate harmony notes (two or three harmonized notes) to a melody you play on the upper keyboard.

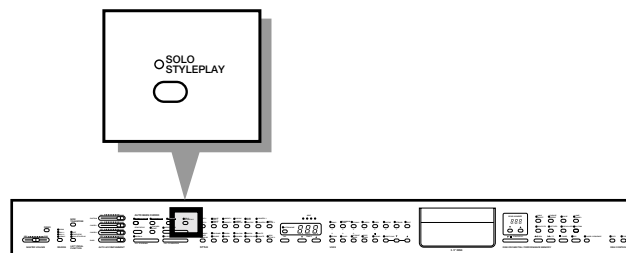

## Using Solo Styleplay

### 1 Turn Solo Styleplay ON



Press the [SOLO STYLEPLAY] button to turn the SOLO STYLEPLAY mode on. The SINGLE FINGER mode is automatically selected when SOLO STYLEPLAY is turned on, unless the FINGERED mode is already selected. If a FULL KEYBOARD mode is selected, the FINGERED mode will automatically be selected since Solo Styleplay cannot be used with the FULL KEYBOARD modes.

### 2 Select a Style

Select an accompaniment style using the style selectors (see “Style Selection” on page 17). An appropriate voice for the selected style will automatically be selected, but you can also select any other voice after selecting the style.

### 3 Set the Tempo

Set the desired tempo if necessary using the TEMPO [▲] and [▼] buttons (see “Tempo Control” on page 17).

### 4 Play

Play the required chords (SINGLE FINGER or FINGERED) on the ABC section of the keyboard while playing a melody line on the upper keyboard (for some styles, only one note can be played at a time on the right-hand section of the keyboard in the Solo Styleplay mode).

### 5 Stop the Accompaniment

Press [START/STOP] or [INTRO/ENDING] to stop the accompaniment.

### 6 Turn Solo Styleplay OFF

Press the [SOLO STYLEPLAY] button again to turn the function off.

## Harmonization Variations

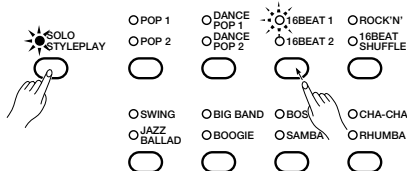

It is possible to apply the harmonization type and voice from a different style to the selected style by pressing the style selector corresponding to the harmonization type you want to use (except for the [DISK STYLE 1/2] selector) while holding the [SOLO STYLEPLAY] button — the selected STYLE button indicator will flash while the [SOLO STYLEPLAY] button is held. This makes it possible, for example, to use the solo styleplay harmonization type and voice from the 16 BEAT 1 style when actually playing in the POP 1 style.

## The Left Pedal & Solo Styleplay

#### CVP-83S/85A



LEFT PEDAL FUNCTION

#### CVP-87A



LEFT PEDAL FUNCTION

If the LEFT PEDAL FUNCTION is set to SOLO STYLEPLAY after the SOLO STYLEPLAY mode is selected, harmonization of notes played on the right-hand section of the keyboard only occurs while the left pedal is pressed. This allows you to combine normal ABC type performance with SOLO STYLEPLAY as required.

The left pedal SOSTENUTO function can not be selected while SOLO STYLEPLAY is on.



- The SOLO STYLEPLAY mode will be disengaged if the ABC FINGERED or SINGLE FINGER mode is turned off or the FULL KEYBOARD ABC mode is turned on.



Using Yamaha Disk Orchestra disks (one is supplied with the CVP-87A, CVP-85A or CVP-83S, others are available from Yamaha), the Clavinova will let you enjoy listening to automated performances, or function as your "private music tutor," allowing you to practice various parts of a piece while the others are played automatically. The CVP-87A additionally shows you which keys to play with keyboard guide lamps that light up above each key. You can also play "in ensemble" with the complete Disk Orchestra arrangement.



- The Disk Orchestra Collection playback data is not transmitted via the MIDI OUT connector.

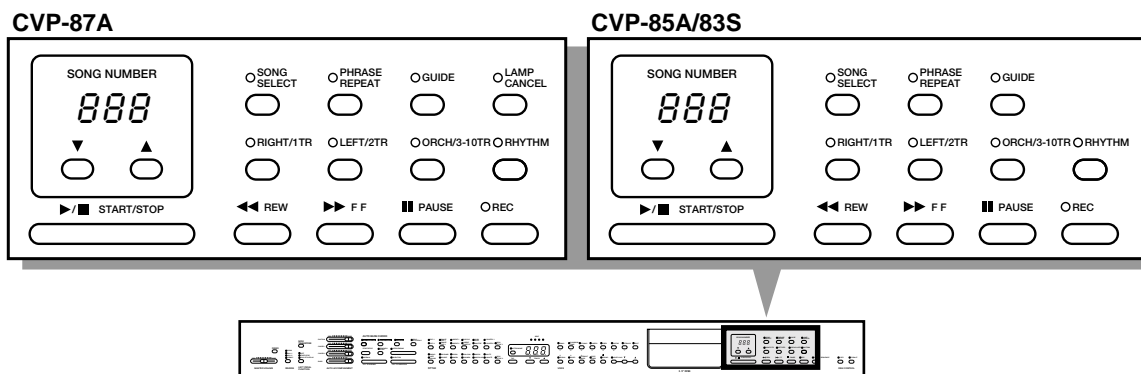

## Automatic Performance

### 1 Insert a Disk Orchestra Disk

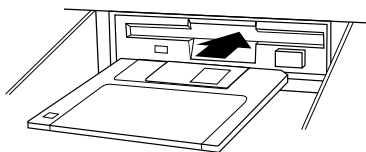

Insert the **DISK ORCHESTRA** disk into the disk drive with the sliding door facing the drive slot and the label side facing upward. The disk should click into place and the disk lamp will light briefly while the Clavinova reads and identifies the disk.



- If a disk is already loaded and the [SONG SELECT] indicator is out, press the [SONG SELECT] button so that the indicator lights before proceeding.

### 2 Select a Song Number

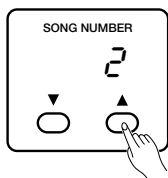

When the disk is inserted the [SONG SELECT], [RIGHT/1TR], [LEFT/2TR], [ORCH/3-10TR], and [RHYTHM] indicators will light if the corresponding tracks contain performance data, and the selected song number will be shown on the **SONG NUMBER** display. Use the [▲] and [▼] buttons below the display to select the desired song number. Select "ALL" if you want all songs on the disk to be played and repeated until playback is stopped.



- You can also start sequential repeat playback by using the [▲] and [▼] buttons to select the song number from which playback is to begin, and then pressing the [START/STOP] button while holding the [MIDI/TRANSCOPE] button.
- The songs can be made to play back and repeat either in sequence or in random order when "ALL" is selected or when starting playback by pressing the [START/STOP] button while holding the [MIDI/TRANSCOPE] button, and playback is started, depending on the setting of the "Random All Song Repeat" utility function (page 43).

### 3 Start Playback

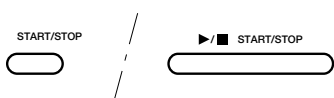

Start playback of the selected song by pressing either the **DISK ORCHESTRA/PERFORMANCE MEMORY** [START/STOP] button or the **ABC** [START/STOP] button. Unless "ALL" is selected, the selected song will play through to the end and playback will stop automatically. The current measure number will be shown on the **TEMPO** display during playback, and the voice indicator used for the RIGHT/1TR and LEFT/2TR parts will light. The voice can be changed as required via the **VOICE** selectors.

Playback can be stopped at any time by pressing the **DISK ORCHESTRA/PERFORMANCE MEMORY** or **ABC** [START/STOP] button.

**NOTES**

- Please note that playback cannot be started while the Clavinova is searching the disk for a selected song.
- With some songs the displayed measure numbers may not match those marked on the score.
- Some songs start after a click count-in.
- The playback tempo can be changed freely as required. The preset tempo for the selected song can be recalled at any time by pressing the TEMPO [▲] and [▼] buttons simultaneously.
- During "RL L" playback three dots will appear along the bottom of the currently-playing song number.
- Some Disk Orchestra software does not produce a tempo display (e.g. free-tempo phrases, etc.). In this case, three lit bars appear along the bottom of the TEMPO display and the numbers shown on the display will not match the actual measure numbers of the song.
- On the CVP-87A the keyboard guide lamps corresponding to the keys being played will light in real time. The keyboard guide lamps can be turned off by pressing the [LAMP CANCEL] button.

**4 Eject the Disk When Done**

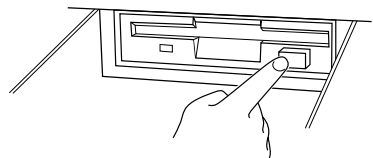

When you've finished with the currently loaded disk, simply press the disk drive EJECT button to remove it.

**CAUTION**

- NEVER eject a disk or turn the power off while:
1. The disk drive lamp is on.
  2. The DISK ORCHESTRA function is playing.

**Playing Back only Specific Parts**

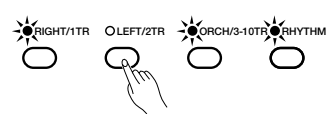

The [RIGHT/1TR], [LEFT/2TR], [ORCH/3-10TR], and [RHYTHM] buttons can be used to select playback of specific parts. The [LEFT/2TR] button turns the left-hand part on or off, the [RIGHT/1TR] button turns the right-hand part on or off, the [ORCH/3-10TR] button turns the ORCHESTRA parts on or off, and the [RHYTHM] button turns the rhythm part on or off. When a part is on, the corresponding LED indicator lights. You can, for example, turn off the right and/or left-hand parts so you can practice them on the keyboard.

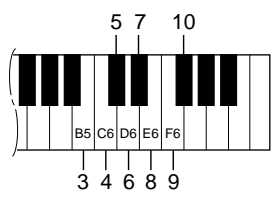

**Turning Individual Orchestra Parts On or Off**

Normally the [ORCH/3-10TR] buttons turns all the orchestra parts (tracks 3 through 10) on or off at once. You can, however, turn these parts on or off individually by pressing the keys shown in the illustration to the left while holding the [ORCH/3-10TR] button:

Press the key once to display the status of the corresponding track on the SONG NUMBER display, and a second to turn the track on or off. The status of the track is indicated by a dot to the right of the rightmost digit:

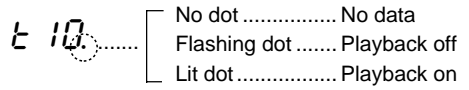

On the CVP-87A the status of tracks 3 through 10 is indicated by the corresponding CVP-87A keyboard guide lamps while the [ORCH/3-10] button is held. If a lamp is out, the corresponding track contains no data. A flashing lamp indicates that playback is off, and a lit lamp indicates that playbacks is on.



## Volume Control

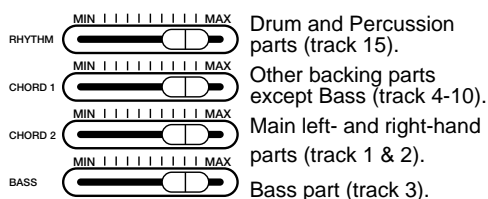

During **DISK ORCHESTRA** playback use the **RHYTHM** volume control to adjust the volume of the drum and percussion parts, the **CHORD 2** volume control adjusts the volume of the main left- and right-hand parts, the **CHORD 1** volume control adjusts the volume of all other parts except the bass, and the **BASS** control adjusts the volume of the bass part.



- When a different song is selected the volume settings will correspond to those in the song data, regardless of the positions of the volume controls.

## Guided Right- and Left-hand Practice

After turning on...

Left- and right-hand guide = or

Right-hand guide only =

Left-hand guide only =

With this feature, the Clavinova waits for you to play the appropriate keys before playing ahead, so you can learn to play the piece at your own pace.

Press the **[GUIDE]** button so that its indicator lights to turn the guide mode on. The settings of the **[RIGHT/1TR]** and **[LEFT/2TR]** buttons will then determine whether the guide function operates for the left-hand part only, the right-hand part only, or both the right- and left-hand parts, as listed to the left.

When you press the **[START/STOP]** button to begin playback, the introduction will play automatically but then the Clavinova will stop and wait for you to play the next key(s). The CVP-87A indicates the next key(s) to be played via the guide lamps above the keyboard. As you play the appropriate keys, the piece will continue, pausing until you play the right keys each time.

As with automated performance, the song will stop automatically when the end is reached, or it can be stopped at any time by pressing the **[START/STOP]** button.



- Disk Orchestra playback tempo can be set to any desired value after a song has been selected by using the **TEMPO** [**▲**] and [**▼**] buttons.
- The positions of the CVP-87A guide lamps do not change if the transpose function is used to transpose the pitch of the keyboard.
- If the guide lamps flashing above the CVP-87A keyboard distract you, or you want to try playing along without them, simply press the **[LAMP CANCEL]** button so that its indicator lights. Repeat to turn the guide lamps back on.
- The **[PAUSE]**, **[REW]** and **[FF]** buttons will not operate when the guide function is in use.

### ● Guide Modes

The Clavinova has two guide modes which can be selected as follows:

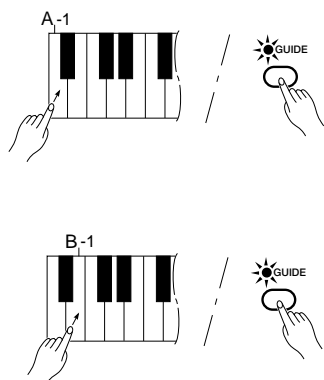

#### ● Normal Wait:

This mode is automatically selected when the power is turned on. It can also be selected by pressing the **A-1** key (the lowest key) while holding the **[GUIDE]** button.

In the normal wait mode the Clavinova will wait until the appropriate key or chord (indicated by the keyboard guide lamps on the CVP-87A) is played before proceeding to the next note.

#### ● Delayed Wait:

This mode can be selected by pressing the **B-1** key (the second-to-lowest white key) while holding the **[GUIDE]** button.

In the delayed wait mode the Clavinova will play ahead for 8 quarter-note beats (two measures in 4/4 time) and then wait until the appropriate key or chord (indicated by the keyboard guide lamps on the CVP-87A) is played.



# Repeat Functions

## ● Phrase Repeat

Use this function if you want to practice a specific phrase within a song, as indicated by the phrase marks on the Disk Orchestra Collection score.

### 1 Select a Song .....

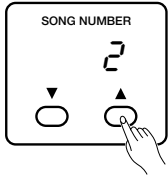

Press the [SONG SELECT] button so that its indicator lights and select the desired song by using the [▲] and [▼] buttons below the SONG NUMBER display.

### 2 Turn Phrase Repeat ON and Select a Phrase Number .....

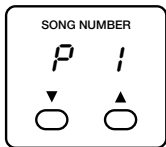

Press the [PHRASE REPEAT] button (its LED indicator will light). When this is done the SONG NUMBER display will function as the phrase number display. Use the [▲] and [▼] buttons below the display to select the desired phrase number (refer to the DISK ORCHESTRA COLLECTION book that comes with the DISK ORCHESTRA COLLECTION disk).

### 3 Select a Part to Practice .....



Use the [RIGHT/1TR], [LEFT/2TR], [ORCH/3-10TR], and [RHYTHM] buttons to turn playback of the various parts on or off, as required.

### 4 Start Playback .....

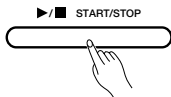

Press the [START/STOP] button to begin playback of the selected phrase. Phrase playback will repeat until the [START/STOP] button is pressed a second time.



- The count-in may not sound with some songs — e.g. those that do not include a rhythm track.

## ● A-B Repeat

This function allows you to specify any section of a DISK ORCHESTRA song for continuous repeat playback.

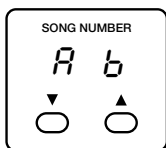
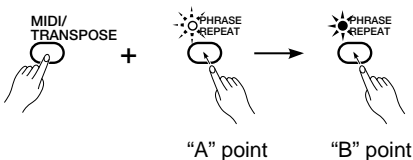

While the song is playing, hold the [MIDI/TRANPOSE] and press the [PHRASE REPEAT] button once at the beginning of the section to be repeated (the “A” point) and again at the end of the section to be repeated (the “B” point). Repeat playback will begin automatically from the A point as soon as the B point has been specified. The programmed A and B points are retained until a different song number or mode is selected, and the A-B phrase can be selected again for repeat playback after playback has been stopped by following the Phrase Repeat procedure described above and selecting “A - b” instead of a phrase number in step 2.



- The specified A-B repeat points will be erased when a new song number is selected.



## Other Playback Controls

### ● Pause



Press the [**PAUSE**] button to temporarily stop DISK ORCHESTRA playback. Press the [**PAUSE**] button again (or the [**START/STOP**] button) to resume playback from the same point.

### ● Rewind and Fast Forward



During DISK ORCHESTRA operation the [**REW**] and [**FF**] buttons function as follows:

- While playback is stopped or paused the [**REW**] and [**FF**] buttons can be used to step backward or forward through the song a measure at a time. Either button can also be held for continuous stepping in the specified direction.
- During playback the [**REW**] and [**FF**] buttons allow you to move rapidly in the specified direction for as long as the button is held. No sound is produced during [**REW**] operation.



- Using the [**REW**] button may cause the voice, tempo, and/or volume to change.
- The [**PAUSE**], [**REW**] and [**FF**] buttons do not function while a guide mode is engaged.

### ● Pedal Pause/Next Phrase

#### CVP-83S/85A



LEFT PEDAL  
FUNCTION

#### CVP-87A



LEFT PEDAL  
FUNCTION

If the left pedal is set for **START/STOP** operation using the [**LEFT PEDAL FUNCTION**] button, it functions as a pause/next phrase control during DISK ORCHESTRA playback: press once to pause, and again to continue from the beginning of the next phrase (refer to the DISK ORCHESTRA COLLECTION book that comes with the DISK ORCHESTRA COLLECTION disk for phrase locations).



- The pedal pause/next phrase function will not operate if the guide, phrase repeat, or all songs repeat modes are active.

## DISK ORCHESTRA COLLECTION Disk Copy

The [**ORCH/3-10TR**] and [**RHYTHM**] parts of songs from DISK ORCHESTRA COLLECTION disks — the disk supplied with the Clavinova and others available from Yamaha — can be copied to separate disks by following the “Copying Disk Orchestra Disks” instructions given on page 39 of the “Disk Control” section. Data copied in this way can be played back and manipulated via the Performance Memory (page 31) — you can, for example, record your own [**RIGHT/1TR**] and [**LEFT/2TR**] parts.



- Disk Orchestra Collection phrase marks are not copied.

## Playing Other Types of Music Data

In addition to Disk Orchestra Collection disks, the Clavinova can also play back Yamaha Disklavier PianoSoft™ disks, disks containing Yamaha ESEQ format sequence data, and disks containing songs recorded in Standard MIDI File format (format 0 only).

It is possible to change the track 1/2 voice by using the panel voice selectors during playback of Disk Orchestra Collection and Disklavier PianoSoft disks. In this case the playback voice will become the same as the voice played via the keyboard. The playback voice cannot be changed when playing back other type of disks (the keyboard voice can be changed).

The phrase repeat function described above can only be used with Disk Orchestra Collection disks. A-B repeat can be used with any type of data. The guide function (and the keyboard guide lamps on the CVP-87A) can only be used with ESEQ files.

The [**ORCH/3-10TR**] part select button can also be used with all types of data: with files other than General MIDI files it turns tracks 3 through 14 on or off, and with General MIDI Files it turns tracks 3 through 9 and 11 through 16 on or off. The [**RHYTHM**] button can be used to turn track 15 on and off with file types other than General MIDI (with General MIDI files the [**RHYTHM**] button turns track 10 on and off). With any type of file the individual tracks (1 through 16) can be turned on and off as described on page 27 — tracks 11 through 16 are controlled by keys G6 through C7, respectively.

When playing files other than General MIDI files the Auto Accompaniment volume controls affect the following tracks (the volume of General MIDI format tracks cannot be controlled):

BASS	Track 3
CHORD 2	Tracks 1 & 2
CHORD 1	Tracks 4 ... 14
RHYTHM	Track 15

When playing General MIDI Files the Clavinova's internal tone generator is automatically switched to the GM System Level 1 voice allocation.

The CVP-87A, CVP-85A, and CVP-83S feature a built-in “sequencer” which can be used to independently record up to ten separate parts of a single musical composition, plus a rhythm track. Each part is recorded on one of the Performance Memory “tracks” accessed via the [RIGHT/1TR], [LEFT/2TR], [ORCH/3-10TR], and [RHYTHM] buttons. The music data that you record is stored on a 3.5" floppy disk loaded into the Clavinova's disk drive unit. Up to approximately 60 songs can be recorded on a single disk, depending on the amount of data contained in each song. Before you can record, however, you must “format” a new disk, as described on page 38.



• The Performance Memory playback data is not transmitted via the MIDI OUT connector.

CVP-87A

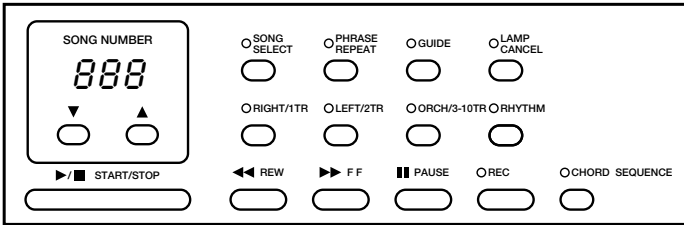

CVP-85A/83S

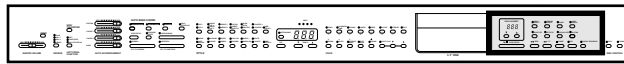
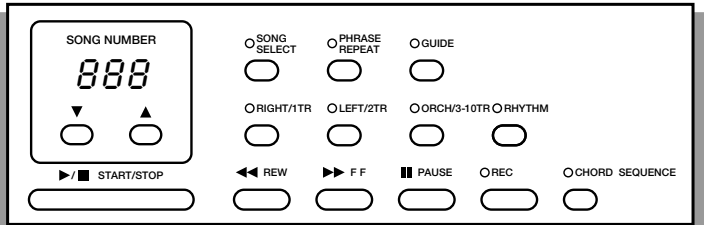

## Easy One-pass Recording & Playback

### 1 Insert a Formatted Disk

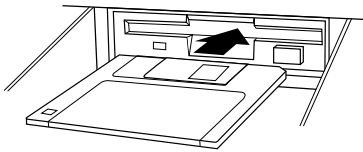

If you haven't already done so, make sure that a properly formatted disk is loaded into the Clavinova disk drive (see page 38), and that the disk's write protect tab is set to the “write” position (tab closed).



- If you insert an unformatted disk, “F<sub>o</sub>r” will appear on the SONG NUMBER display. Please format the disk before proceeding.
- If a disk is already loaded and the [SONG SELECT] indicator is out, press the [SONG SELECT] button so that the indicator lights before proceeding.

### 2 Select a Song Number

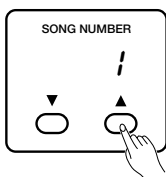

Select a **SONG NUMBER** between 1 and 60 for the piece you are about to record (up to 60 different songs, each with a different song number, can be recorded on a single disk). Make sure the song number you select has not already been used for a song previously recorded on the disk you are using.



- If the [RIGHT/1TR], [LEFT/2TR], [ORCH/3-10TR], or [RHYTHM] button indicator glows green when a song number is selected, the corresponding track of the selected song already contains recorded data. Before recording over a song that contains previous data, we recommend that you delete the entire song as described in “Deleting a Song” on page 40.

### 3 Select a Voice

Use the **VOICE** selectors to select the voice you want to record with. You can try out the selected voice on the keyboard before proceeding.

### 4 Engage the Record Ready Mode

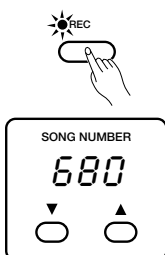

Press the [REC] button so that its indicator lights. The [RIGHT/1TR] indicator should also glow red at this point, indicating that you are ready to record on track 1.

#### ● Remaining Disk Space Display

When you release the [REC] button the amount of disk space available for recording will appear on the **SONG NUMBER** display (in approximate kilobytes). With an empty disk you should have about 700 kilobytes of space for recording (room enough for about 50,000 notes if no other Clavinova functions are used). If no space is available for recording, “F<sub>U</sub>L” will appear on the display.

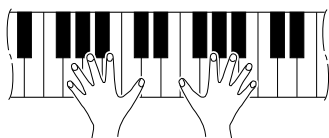

**5 Start Recording**.....

Play on the keyboard. Recording will begin automatically as soon as you start playing.

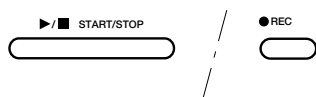

- You can turn the metronome on before or during recording (the metronome sound will not be recorded).

**6 Stop Recording**.....

Stop recording by pressing the [START/STOP] button or the [REC] button. When recording has finished the indicator of the recorded track will glow green, indicating that the track is ready for playback.



- The Clavinova may continue to write data to the disk for a short time after you stop recording. “r-Ec” will appear on the display while this occurs. DO NOT eject the disk while this display is showing.

**7 Play Back the Recording**.....

Press the [START/STOP] button to play back your recording. Play along on the keyboard if you like. During playback you can use the [II PAUSE], [◀ REW], and [▶▶ FF] buttons, as described on page 30. You can also change the playback tempo via the TEMPO [▲] and [▼] buttons.

**8 Stop Playback**.....

Playback will stop automatically when the end of the recording is reached, or you can press the [START/STOP] button to stop it at anytime.

## Multi-track Recording & Playback

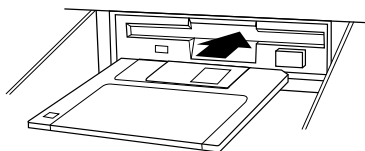
**1 Insert a Formatted Disk**.....

If you haven't already done so, make sure that a properly formatted disk is loaded into the Clavinova disk drive (see page 38), and that the disk's write protect tab is set to the “write” position (tab closed).

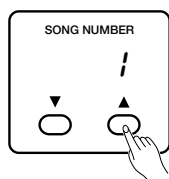

- If a disk is already loaded and the [SONG SELECT] indicator is out, press the [SONG SELECT] button so that the indicator lights before proceeding.

**2 Select a Song Number**.....

Select a **SONG NUMBER** between 1 and 60 for the piece you are about to record (up to 60 different songs, each with a different song number, can be recorded on a single disk). Make sure the song number you select has not already been used for a song previously recorded on the disk you are using.

**3 Set All Performance Features As Required**.....

Set up all necessary performance features as required: voice, voice mode (normal, dual, or split), style, tempo, left pedal function, etc. Try out the features as you select them to check that you have the right overall sound.

**4 Engage the Record Ready Mode**.....

Press the [REC] button so that its indicator lights. The [RIGHT/1TR] indicator should also glow red at this point, indicating that you are ready to record on track 1. As soon as you release the [REC] button the first dot of the beat indicator will begin to flash at the currently set tempo.



- Be careful not to start recording prematurely by either playing the keyboard or pressing the [START/STOP] button before you've completed the following steps.

**5 Select the Track(s) to Record** .....

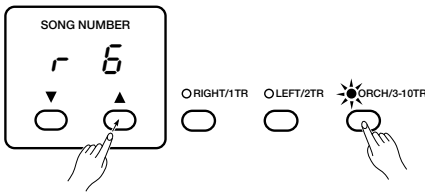

Only one track can be recorded at a time. If you press [RIGHT/1TR] you will record on track number 1. If you press [LEFT/2TR] you will record on track number 2. If you press [ORCH/3-10TR], you can choose to record on track 3, 4, 5, 6, 7, 8, 9, or 10 by selecting the desired track number using the [▲] and [▼] buttons below the SONG NUMBER display while holding the [ORCH/3-10] button (the selected track number will appear on the SONG NUMBER display). When a record track has been selected the corresponding indicator will light.

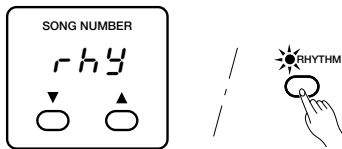

● **Recording with Rhythm**

To record a rhythm in addition to the part you play on the keyboard, select the desired style via the STYLE selectors and press the [RHYTHM] button so that its indicator glows red. “r h 4” will appear on the SONG NUMBER display while the [RHYTHM] button is held. The rhythm data will be recorded on track 15.

If you only want to record the rhythm track, de-select all other selected tracks by pressing their buttons so that their indicators go out.

If you select the rhythm track for recording, or the rhythm track already contains data, the metronome will sound at the current tempo.

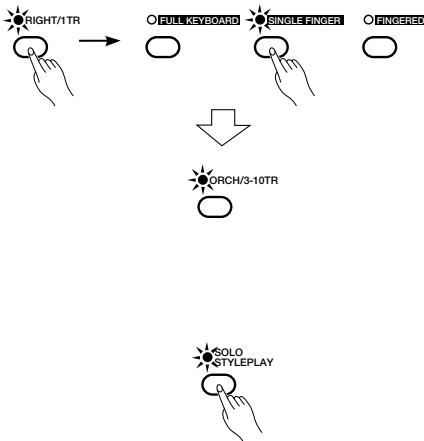

● **Recording with ABC**

When recording with ABC auto-accompaniment the keyboard part can only be recorded to track 1 or 2. To record with ABC press the [RIGHT/1TR] or [LEFT/2TR] button and then engage an ABC mode. The [ORCH/3-10TR] and [RHYTHM] indicators will light automatically in addition to the [RIGHT/1TR] or [LEFT/2TR] indicator, and the ABC sound will be recorded on tracks 3 through 10 while what you play on the keyboard will be recorded on track 1 or 2. If you only want to record the ABC sound, de-select track 1 or 2 by pressing the appropriate button so that the indicator goes out. In the same way, de-select the [RHYTHM] track if you don't want to record the rhythm sound.

● **Recording with Solo Styleplay**

If you also select solo styleplay, the solo styleplay sound will be recorded on tracks 11 through 14. Solo Styleplay can be recorded at the same time as SINGLE FINGER or FINGERED ABC, but not at the same time as FULL KEYBOARD mode ABC.

**6 Start Recording** .....

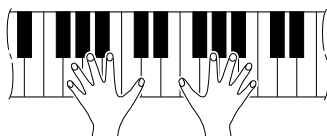

The synchronized start mode is automatically selected when the record ready mode is engaged, so recording will begin automatically as soon as any key on the keyboard is pressed or the [START/STOP] button is pressed (see page 18 for the various synchro start modes). The current measure number is shown on the TEMPO display as you record.

The following parameters will be recorded in addition to notes you play:

**Parameters recorded for Each Track**

- Voice\*
- Dual Voice\*
- Split Voice\*
- Volume\* (Not changeable during recording)
- Expression (Not recorded as an initial setting)
- Pan\*
- Damper Pedal\*
- Soft Pedal\*
- Sostenuto Pedal (Not recorded as an initial setting)
- Modulation\*
- Pitch Bend\*
- Reverb Depth\* (Not recorded as an initial setting)
- Dual Balance\*
- Split Balance\*

**Parameters Recorded for the Entire Song**

- Style
- Rhythm Volume\*
- Reverb Type\*
- Reverb Depth\*
- Tempo\*
- Intro Mode (Not changeable during recording)
- Ending Mode (Not recorded as an initial setting)
- Fill-in
- ABC Mode (Not changeable during recording)
- ABC Volume\*
- Solo Styleplay Mode (Not changeable during recording)
- Solo Styleplay Variation (Not changeable during recording)

**Parameters Recorded for Each Track via MIDI Only**

- Pitch Bend Sensitivity (Not recorded as an initial setting)
- Coarse Tune (Not recorded as an initial setting)
- Fine Tune (Not recorded as an initial setting)

**7 Stop Recording** .....



Press the [REC] button a second time, or the [START/STOP] button to stop recording.



## ■ Adding New Tracks

When you've finished recording the first track, you can simply play it back as described in the previous section or add a new track to your song. To record a new track:

### 1 Select a Voice .....

Select a voice and other parameters for the new track. Try out the voice and selected parameters before proceeding.

### 2 Engage the Record Ready Mode .....



Press the [REC] button to engage the record ready mode.

#### ● Monitoring Previously Recorded Tracks

All previously recorded tracks are automatically selected for playback when the record mode is engaged. You can turn these tracks on or off as required by pressing the corresponding track button(s) before pressing the [REC] button.

### 3 Select a Track .....

Select a track other than the one you used to record the previous track. The indicator of the track selected for recording should glow red.



- Remember that if you record on a track that has already been recorded, the previous material will be erased and the new material will be recorded in its place.

### 4 Start Recording .....

Play on the keyboard or press the [START/STOP] button to start recording.

### 5 Stop Recording .....

Press the [START/STOP] button or the [REC] button to stop recording.

#### ● Changing the Initial Parameter Values

The initial values of parameters marked with asterisks (\*) in the lists given in step 6 on page 33 can be changed for each track or the entire song by engaging the record mode for the desired track, changing the parameters as required, and then disengaging the record mode (press the [REC] button again) without actually recording. To cancel any initial parameter values you've made, select a different track and then press the [REC] button to disengage the record mode.

To change individual ABC part volume settings engage any ABC mode after turning [REC] on, set the **RHYTHM**, **CHORD 1**, **CHORD 2**, and/or **BASS** volume control as required, then disengage the record mode.

The **BASS** volume control can be used while holding the [MIDI/TRANSPOSE] button to independently adjust the volume of each track (except the rhythm track).

The volume of the rhythm track is adjusted via the **RHYTHM** volume control. Please note that volume settings can only be decreased.

Individual track reverb depth can be adjusted by using the **BASS** volume while holding the [REVERB] button, and the overall reverb depth can be adjusted by using the **TEMPO** [▲] and [▼] buttons while holding the [REVERB] button.

Also note that the tempo, reverb type, style, style variation, fill-in, and intro/ending settings are common to all tracks and cannot be set independently for different tracks.

#### ● Erasing the Tracks

Individual tracks — except the rhythm track — can be completely erased by starting and stopping recording without actually playing or changing any parameters (i.e. press the [START/STOP] button twice). The same procedure can be used to erase the rhythm track if the **RHYTHM** volume control is set to its minimum position.



- Tracks 3-10 can be erased by engaging the record mode, turning ABC on, and then pressing the [START/STOP] button twice.

#### ● Recording Without a Disk

The Clavinova has enough internal RAM memory to allow recording for a while even if a disk is not loaded (up to approximately 1,600 notes if no other data is recorded). If you accidentally record without loading a disk, make sure you use the COPY function (described on page 39) to copy the recorded data to disk if you want to keep the recorded data (the internal RAM memory is not backed up). This is necessary because the internal RAM memory is cleared automatically when a Disk Orchestra Collection, Disklavier PianoSoft, or Style Disk is loaded, or a performance disk is loaded and the [SONG SELECT] button is pressed.



Volume of each track



# Punch-in Recording

“Punch-in recording” allows you to start recording from any point within a previously-recorded track, leaving all recorded material up to the punch-in point intact.

## 1 Play the Song

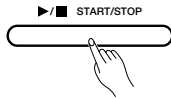

Play back the song in order to locate the point you want to punch-in from. You can also use the [FF] and [REW] buttons to locate the punch-in point.

## 2 Pause Before the Punch-in Point



Press the [PAUSE] button to pause playback a bit before the point at which you want to start recording. Leave a measure or more before the punch-in point so you'll be able to grasp the timing for the punch in.

## 3 Engage the Record Ready Mode



Press the [REC] button to engage the record ready mode. The last track selected for recording will automatically be reselected.

## 4 Select a Track

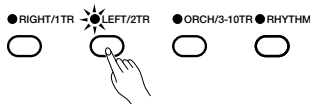

If you want to record on a different track than the one that is currently selected for recording (red indicator), use the normal track selection procedure.

## 5 Start Playback & Recording



Press the [START/STOP] button to start playback from the current pause location, then begin playing at the point you want to record from. Recording will begin as soon as you begin playing on the keyboard.



- Since all material after the punch-in point will be erased, be sure to play right through to the end of the track once recording has begun.

## 6 Stop Recording

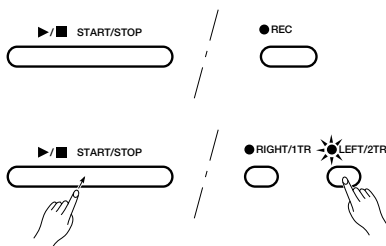

Press the [START/STOP] button or the [REC] button to stop recording.

### Erasing All Material From the Punch-in Point

If at step 5, above, you press the [START/STOP] button while holding the track button corresponding to the track on which you want to record, recording will begin immediately. If you then stop recording without actually playing anything, all recorded material from the punch-in point to the end of the track will be erased.



- Punch-in recording cannot be used with ABC, SOLO STYLEPLAY, or RHYTHM tracks.



## ■ Playback

Original Performance Memory recordings can be played back and controlled in the same way as described in the Disk Orchestra section, beginning on page 26. You can individually select tracks to play back (page 27), use the guide function (and the keyboard guide lamps on the CVP-87A) with the data recorded on tracks 1 and 2 (page 28), and use the A-B repeat function (page 29).



- *The playback voice cannot be changed when playing back Performance Memory data (the voice played via the keyboard can be changed).*

### ● Volume Control

The **RHYTHM**, **CHORD 1**, **CHORD 2**, and **BASS** volume controls can be used to adjust the volume of the corresponding accompaniment parts when playing back data that was recorded with ABC.

When playing back data that was recorded without ABC, however, these volume controls have the following track assignments.

<b>RHYTHM:</b>	RHYTHM track
<b>CHORD 1:</b>	4 - 10 tracks
<b>CHORD 2:</b>	1 & 2 tracks
<b>BASS:</b>	3 track

### ● Multi-timbre Recording via MIDI

Data from an external MIDI device such as a sequencer or music computer can also be recorded to the Performance Memory as follows:

#### 1 Make the Required MIDI Connections

Connect the **MIDI OUT** terminal of the transmitting device to the Clavinova's **MIDI IN** terminal using a standard MIDI cable.

#### 2 Select the External Clock Mode

To select the external clock mode press the **[ORGAN] VOICE** button while holding the **[MIDI/TRANSPOSE]** button. When selected, the **[ORGAN]** indicator will light while the **[MIDI/TRANSPOSE]** button is pressed. In this mode the Clavinova is controlled by an external MIDI clock signal.

#### 3 Select a Song Number

Select the song number to which you want to record the data by using the **SONG NUMBER [▲]** and **[▼]** buttons (of course, a properly formatted floppy disk must already be loaded in the disk drive).

#### 4 Engage the MIDI Record Ready Mode

Press the **[REC]** button while holding the **[MIDI/TRANSPOSE]** button to engage the MIDI record ready mode. In this mode all tracks (1 through 15) can be recorded at the same time via the

correspondingly numbered MIDI channels. That is, MIDI data received on channel 1 will be recorded on track 1, data received via channel 2 will be recorded on track 2, etc.

#### 5 Match the Time Signature & Tempo

Select a style having a time signature that matches that of the data you are going to record (e.g. 4/4, 3/4), and match the Clavinova tempo setting to that of the data to be recorded.

#### 6 Record the MIDI Data

Play back the MIDI data on the sequencer, music computer, or other device. Recording will start and stop automatically.



- *Please note that the Clavinova's internal styles cannot be played during multi-timbre recording.*
- *Any notes played on the keyboard and other setting changes will be recorded on track 1 during multi-timbre recording.*
- *Initial panel settings will not be recorded unless the settings are changed in the record ready mode.*
- *Previous data on all tracks will be erased when new data is recorded in the multi-timbre mode.*
- *Be sure to turn the multi-timbre and external clock modes off when you're finished multi-timbre recording (see pages 49 and 50).*



# The Chord Sequence Function

The **CHORD SEQUENCE** function provides a convenient way to enter chord sequences and style changes one at a time.

## 1 Engage the Chord Sequence Function

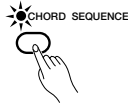

Press the [**CHORD SEQUENCE**] button. The [**ORCH/3-10TR**] and [**RHYTHM**] track button indicators will glow red, and the **ABC FINGERED** mode will be automatically selected — switch to the **SINGLE FINGER** mode if you prefer. If the **SINGLE FINGER** mode was already selected it will remain engaged.



- The chord sequence data will replace any previous ABC data.

## 2 Enter the Chords and/or Style Changes

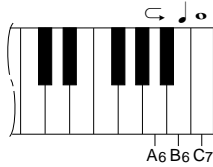

Make the required style changes (style number, normal/variation, fill-in, intro/ending, and tempo, as necessary), play and hold a chord on the left-hand section of the keyboard, and press the [**♪**] key (look for the “♪” symbol above the B6 key) or the [**○**] key (C7) to enter the chord for a quarter note or whole note, respectively. You can move one beat backward by pressing the [**←**] key (A6).

Continue entering chords in this manner until your sequence is complete.

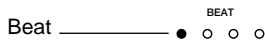

Measure number

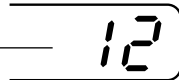

- The number of the measure to be entered is shown on the **TEMPO** display, while the beat to be entered is shown on the **BEAT** display.
- If no chords are entered, the result will be a rhythm-only sequence.

## 3 Stop Recording

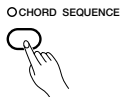

When all the required chords and style changes have been entered, press the [**CHORD SEQUENCE**] button to stop recording.



- The chord sequence data now resides in Performance Memory tracks 3 through 10 and 15, and can be played back in the normal way. Add melody tracks 1 and 2 as required. You can also record over individual tracks of the sequence and replace them with original material if you like by using the standard Performance Memory track selection and record procedure.

### ● Punch-in Chord Sequence Recording

You can begin chord sequence recording from any point within a previously-recorded song by pausing playback at the point you want to begin chord sequence recording, engaging the Chord Sequence function at that point, and entering the chords up to the end of the sequence as described above.



- If you attempt punch-in chord sequence recording on a song in which no chord sequence data has been entered, “no” will appear on the **SONG NUMBER** display and the recording will not be possible.
- If you record chord sequences to all songs on a disk, the maximum number of songs available on that disk will be 55.



This chapter describes several important disk control functions: Formatting new disks, copying songs, and deleting songs.

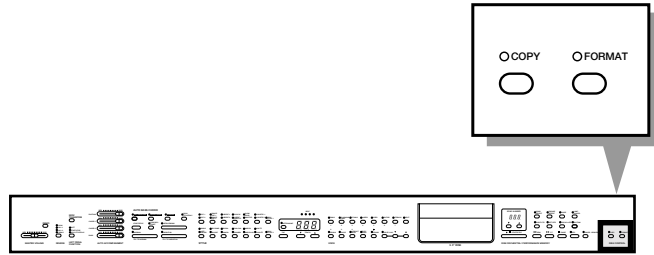

## ■ Formatting a New Disk

The Clavinova uses only 3.5" 2DD floppy disks. We recommend that you use Yamaha 2DD disks. Before you can use a new disk for recording, the disk must be "formatted" so that the Clavinova can recognize it and correctly write the music data onto it.

### 1 Insert the Disk To Be Formatted

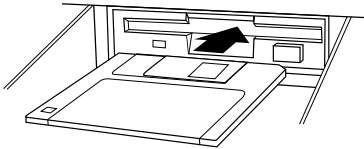

Insert a new blank disk. Make sure that the disk's write protect tab is set to the "write" position (tab closed), and insert the new disk into the disk drive unit with the sliding door facing the drive slot and the label side of the disk facing upward. The disk should click securely into place, and the disk drive lamp should light briefly.

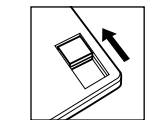
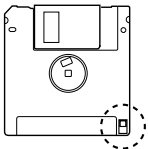

Write protect tab closed (unlocked — write enabled)



- "For" will appear on the SONG NUMBER display to indicate that a blank (unformatted) disk is loaded in the drive.
- "Pro" will appear if a protected disk that cannot be formatted is loaded in the drive: a write-protected disk, a Disk Orchestra Collection disk, a Disklavier disk, or a disk formatted by the Disklavier.

### 2 Engage the Format Function



Press the **DISK CONTROL [FORMAT]** button. The **[FORMAT]** button LED will flash and "n 4" will appear on the **SONG NUMBER** display.

### 3 Confirm the Format Operation

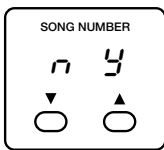

Use the **SONG NUMBER [▲]** and **[▼]** buttons to select either "n" (NO) or "4" (YES) on the display. "4" if you intend to execute the format operation or "n" if you wish to cancel the operation. This step is necessary because formatting completely erases any data that is already on the disk — make sure that the disk you're about to format does not contain any important data!

### 4 Start Formatting



If you selected "4" in the previous step, press the **[FORMAT]** button again and formatting will begin. The number of each "track" on the disk will be shown on the display as the format process continues ("F80" through "1"). When formatting is complete (the display will show "1"), you can go ahead and record using the performance memory, or use the COPY function (below) to copy songs or Disk Style data to the disk.



- The format operation can be aborted at any time prior to actually starting the format operation by pressing the **[START/STOP]** button. In this case, the disk will have to be properly formatted again before use.



## ■ Copying Songs

Song data can be “backed up” by copying to a new song number or a different disk, as follows:

### 1 Select the Source Song .....

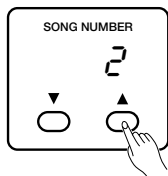

Press the [SONG SELECT] button and use the [▲] and [▼] buttons below the **SONG NUMBER** display to select the number of the song you wish to copy.

### 2 Engage the Copy Function .....



Press the [COPY] button. The [COPY] button LED will flash.

### 3 Select the Destination Song .....

c 1..... c60  
Copy to same disk

c̄ 1..... c̄60  
Copy to different disk (Song number greater than 60)

Use the [▲] and [▼] buttons below the **SONG NUMBER** display to select the song number you wish to copy to (i.e. the destination song number). If you select a song number that already contains data, that data will be overwritten by the new song data. If you select a song number greater than 60 (c̄ 1 through c̄ 60 will appear on the display), the copy will be made to a different disk.

### 4 Start Copying .....

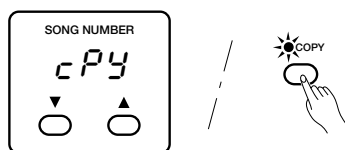

Press the [COPY] button again to begin the actual copy operation. “cPY” will appear on the **SONG NUMBER** display and the [COPY] indicator will light continuously during the copy operation.

If you chose to copy to a different disk, you may have to exchange the source and destination disks a few times if the song being copied is long and complex. In this case, the Clavinova will prompt you to insert the source and destination disks with the displays shown to the left.

d 1 Insert source disk.

d 2 Insert destination disk.

- While the data is being copied the number of times the disks will have to be exchanged to complete the copy operation will be shown on the display.

**NOTES**

- If you copy to a song number that already contains data, the Clavinova will ask you to confirm the copy operation. Use the **SONG NUMBER** [▲] and [▼] buttons to select either “n” (NO) or “y” (YES) on the display. “y” if you intend to execute the copy operation or “n” if you wish to cancel the operation. The copy operation will begin automatically if you select “y”.
- The copy operation can be aborted at any time prior to actually starting the copy operation (i.e. while the [COPY] indicator is flashing) or during the disk exchange display (“d 1” or “d 2”) by pressing the [START/STOP] button.

### ● Copying Disk Orchestra Disks ([ORCH/3-10TR] and [RHYTHM] parts only) .....

All Disk Orchestra data except the right-hand and left-hand parts can be copied to a separate disk by following the standard copy procedure outlined above. The copied data cannot, however, be copied a second time to another disk.

### ● Copying the Style Disk Data .....

All Style Disk data can be copied to a separate disk by following the standard copy procedure outlined above. A single disk can hold up to 50 styles. Style Disk data can only be copied to a newly formatted disk (i.e. no other data can be previously recorded on the disk) or a disk which already contains copied style data.

**NOTES**

- Data from the Style Disk cannot be copied to a disk that contains Performance Memory or Disk Orchestra Collection data. The reverse is also true: Performance Memory and Disk Orchestra Collection data cannot be copied to a disk that contains data copied from the Style Disk.

### ● Copying Data Recorded Without a Disk .....

If you’ve used the performance memory to record data without first loading a disk: press the [COPY] button, insert a formatted disk, then select the destination song number and copy as described above.

**NOTES**

- Data cannot be copied from Disklavier disks, or Standard MIDI File disks. Data cannot be copied to any write protected disk. It is also not possible to copy from one song number to another within the same Disk Orchestra disk.



## ■ Deleting a Song

You can delete any song from a loaded disk as follows:

### 1 Engage the Delete Function

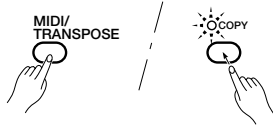

Press the [COPY] button while holding the [MIDI/TRANPOSE] button. The [COPY] LED will flash and “d 1” will appear on the SONG NUMBER display.

### 2 Select the Song to Delete

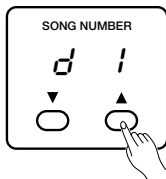

Use the SONG NUMBER [▲] and [▼] buttons to select the song number you wish to delete.

### 3 Confirm & Execute the Delete Operation

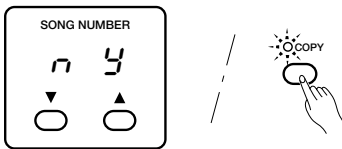

Press the [COPY] button a second time — “n 4” will appear on the SONG NUMBER display. Use the SONG NUMBER [▲] and [▼] buttons to select either “n” (NO) or “4” (YES) on the display. “4” to immediately delete the selected song, or “n” if you wish to cancel the operation.

#### NOTES

- The delete operation can be aborted at any time prior to actually starting the delete operation (i.e. while the [COPY] indicator is flashing) by pressing the [START/STOP] button.
- Data recorded to memory without loading a disk can be deleted simply by executing step 1 and selecting “n” or “4”.
- Data cannot be deleted from any write protected disk, the supplied Style Disk, Disk Orchestra Collection disks, or Disklavier disks.

## ■ Error Messages

If an error related to the disk occurs, one of the following messages may appear. If this happens, check the possible causes and solutions listed below. If all else fails, try a different disk. If this doesn't clear up the problem, contact your Yamaha dealer.

### **dEr** Disk Error.

An error occurred while writing to or reading from the disk.

Try the operation again; if the error occurs a second time the disk or drive may be faulty. If the drive has been in use for some time the heads may be dirty. Clean the heads with a commercially-available floppy disk head cleaner. If the error still occurs with one disk and not others the disk should be considered faulty and should be discarded. If the error occurs with all disks the drive may be faulty. Refer the problem to your Yamaha dealer.

### **Pro** Write Protected.

You have attempted to format, write to, copy to, or delete data from a write-protected disk. Use a disk that is not write protected (set the disk's write-protect tab to the write-enable position).

### **For** Unformatted Disk.

The loaded disk is not formatted for use with the Clavinova. After making sure that the disk does not contain any important data (for another device, for example), format the disk as described on page 38.

The “general utility functions” in this group apply to a wide range of functions and features. There are 10 functions (11 for the CVP-87) in the group which are accessed as follows:

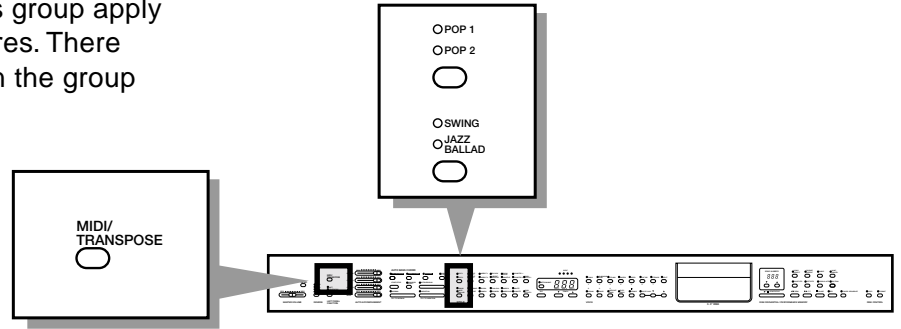

## 1 Select a Utility Function

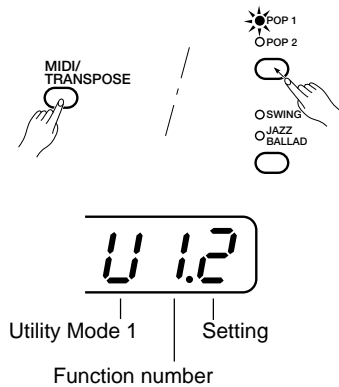

Use the [POP 1/POP 2] and [SWING/JAZZ BALLAD] style selectors while holding the [MIDI/TRANSPOSE] button. The [POP 1/POP 2] style selector increments the utility function number each time it is pressed, and the [SWING/JAZZ BALLAD] button decrements the utility function number.

The Utility Mode 1 functions are indicated on the **TEMPO** display by a tall “U” in the leftmost digit position. The number of the function is displayed by the center digit (“1” through “9”, “A” and “b”), and the current setting is shown by the right digit.

The [MIDI/TRANSPOSE] button must be held until after you’ve set the function, below.



- You can cancel the selected function at this point and exit from the utility mode simply by releasing the [MIDI/TRANSPOSE] button.

## 2 Set as Required

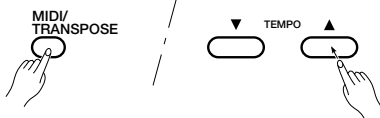

Use the **TEMPO** [▲] and [▼] buttons while still holding the [MIDI/TRANSPOSE] button to select the required setting (the available settings for each utility function are listed below).

## 3 Release the [MIDI/TRANSPOSE] Button to Exit

Release the [MIDI/TRANSPOSE] button to exit from the Utility 1 Mode when you’ve finished making the required settings.

## U 1: Touch Sensitivity

The Clavinova can be set to one of three different types of keyboard touch sensitivity to match different playing styles and preferences.

- 1: Soft. Allows maximum loudness to be produced with relatively light key pressure.
- 2: Medium. Produces a fairly “standard” keyboard response.
- 3: Hard. Requires the keys to be played quite hard to produce maximum loudness.



- The MEDIUM setting (2) is automatically selected whenever the POWER switch is turned on.



## U2: Accompaniment Volume Mode

Normally the Auto Accompaniment volume controls are used to adjust the volume of the Rhythm, Chord 1, Chord 2, and Bass accompaniment parts, as labelled on the Clavinova panel. This function can be used to assign these volume controls to other operations.

- 1*: Rhythm, Chord 1, Chord 2, and Bass volume control.
- 2*: Modulation, Pitch Bend +, Pitch Bend -, and Expression. In this mode the RHYTHM slider controls modulation depth, the CHORD 1 slider controls upward pitch bend, the CHORD 2 slider controls downward pitch bend, and the BASS slider controls expression (overall volume).
- 3*: Reverb depth for the Rhythm, Chord 1, Chord 2, and Bass tracks. This applies when playing with ABC and when playing back performance memory data that was recorded with ABC. When playing back performance memory data that was recorded without ABC, and when playing back Disk Orchestra Collection data, the CHORD 1, CHORD 2 and BASS controls correspond to tracks 4-10, 1-2, and 3, respectively.



- The Rhythm, Chord 1, Chord 2, and Bass volume setting (*1*) is automatically selected whenever the POWER switch is turned on.
- *1* and *2* can be recorded and their initial values can be changed as described on page 34.
- *3* applies only to playback.

## U3: Individual Key Tuning

The Individual Key Tuning Feature makes it possible to individually tune each key on the Clavinova keyboard in order to match different tuning standards. The pitch of each key can be raised or lowered by a maximum of 50 cents (approximately) from the standard pitch.

- F*: Individual key tuning OFF.
- U*: Raise pitch.
- d*: Lower pitch.

### 1 Select Up or Down Tuning

First, use the **TEMPO** [▲] and [▼] buttons to select either “*U*” if you want to raise the pitch of a key or “*d*” if you want to lower the pitch of a key. Remember to keep the [MIDI/TRANSCOPE] button held until step **4**, below.

### 2 Press the Key To Be Tuned Once

Press the key to be tuned once to display the current tuning value on the **SONG NUMBER** display. “*U*” indicates normal pitch, positive values indicate that pitch has been increased by the corresponding number of steps (about 1.2 cents per step), and negative (“-”) values indicate that pitch has been lowered by the corresponding number of steps.

### 3 Press the Key To Tune

Subsequent presses on the key selected in the previous step tune the key in the specified “*U*” or “*d*” direction — one 1.2-cent step per press. The highest and lowest possible values are “44” and “-44”, respectively.

### 4 Select a New Key Or Exit

To tune a different key, repeat steps **1** through **3**, above. To exit from the Individual Key Tuning function, release the [MIDI/TRANSCOPE] key.



- Individual key tuning is automatically turned OFF (*F*) whenever the POWER switch is turned on.
- The Individual Key Tuning data can be saved to and loaded from disk by using the Utility Mode 2 “Save Individual Key Tuning” and “Load Individual Key Tuning” functions (pages 45 and 46).

## U4: Style Tempo Switching

This function determines whether the “suggested” tempo for each style will be automatically selected whenever a style is selected (while style playback is stopped) or whether the currently selected tempo will be maintained regardless of the selected style (refer to page 17).

- n*: Style tempo switching OFF — the current tempo is maintained.
- U*: Style tempo switching ON — the suggested tempo for each style is automatically selected.



- Style tempo switching is automatically turned ON (*U*) whenever the POWER switch is turned on.

## U5: Auto Synchro Start Switching

This function determines whether the “Synchro Start” mode will automatically be turned ON and OFF when an ABC mode is turned ON and OFF (refer to page 20, 21).

$\curvearrowright$ : Auto synchro start switching OFF — synchro start is not turned on and off with ABC.

$\curvearrowleft$ : Auto synchro start switching ON — synchro start is automatically turned on and off with ABC.



- Auto synchro start switching is automatically turned ON ( $\curvearrowleft$ ) whenever the POWER switch is turned on.

## U6: Random All Song Repeat

This function determines whether the songs are played back and repeated in sequential or random order when “ALL” is selected when playing back a disk (refer to page 26). This function also affects demo song playback (page 6).

$\curvearrowright$ : Random all song repeat OFF — the songs are played in sequence.

$\curvearrowleft$ : Random all song repeat ON — the songs are played in random order.



- Random all song repeat is automatically turned OFF ( $\curvearrowright$ ) whenever the POWER switch is turned on.

## U7: Octave Shift

This function determines whether the left-hand voice in a split keyboard setup will be automatically shifted up one octave (refer to page 10).

$\curvearrowright$ : Octave shift OFF — no octave shift will occur.

$\curvearrowleft$ : Octave shift ON — appropriate voices will be shifted.



- Octave shift is automatically turned ON ( $\curvearrowleft$ ) whenever the POWER switch is turned on.

## U8: Mute

Turns the Auto Accompaniment mute function on or off (refer to page 22).

$\curvearrowright$ : Mute OFF.

$\curvearrowleft$ : Mute ON.



- The mute function is automatically turned ON ( $\curvearrowleft$ ) whenever the POWER switch is turned on.

## U9: Minor Harmonization

Turns the Auto Accompaniment minor harmonization function on or off (refer to page 22).

$\curvearrowright$ : Minor harmonization OFF.

$\curvearrowleft$ : Minor harmonization ON.



- The Minor harmonization function is automatically turned OFF ( $\curvearrowright$ ) whenever the POWER switch is turned on.

## UA: Damper Pedal Mode (CVP-87A only)

Sets the CVP-87A damper pedal for on/off or continuous operation (refer to page 14).

$\curvearrowright$ : Continuous damper pedal operation.

$\curvearrowleft$ : On/off damper pedal operation.



- Continuous damper pedal operation ( $\curvearrowright$ ) is automatically selected whenever the POWER switch is turned on.
- In the CVP-85A and CVP-83S this setting is fixed at “ $\curvearrowleft$ ” and cannot be changed.

## Ub: Standard MIDI File Playback Mode

This function determines whether standard MIDI files on floppy disk are played back using the General MIDI voice assignments or the standard Clavinova voice assignments.

$\curvearrowright$ : Standard SMF Mode. Standard Clavinova voice assignments (unless a “GM ON” message is included in the data). Track 10 not necessarily drums.

$\curvearrowleft$ : GM SMF Mode. General MIDI voice assignments. Track 10 is always drums.



- The Standard SMF mode is useful when playing back a disk containing Standard MIDI Files created on an external sequencer using the Clavinova panel voice assignments.
- The GM SMF mode is automatically selected ( $\curvearrowleft$ ) whenever the POWER switch is turned on.



This group of utility functions covers a range of disk-related jobs. There are 6 functions in the group which are accessed as follows:



- *Utility Mode 2 functions can only be accessed when a disk is present in the Clavinova disk drive.*

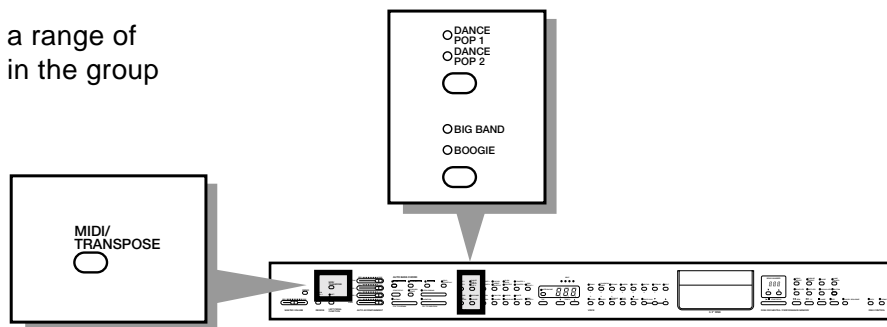

## 1 Select a Utility Function

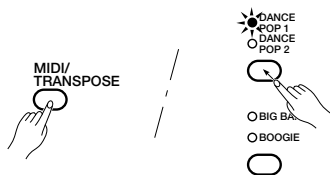

Use the [DANCE POP 1/DANCE POP 2] and [BIG BAND/BOOGIE] style selectors while holding the [MIDI/TRANSPOSE] button. The [DANCE POP 1/DANCE POP 2] style selector increments the utility function number each time it is pressed, and the [BIG BAND/BOOGIE] button decrements the utility function number.

The Utility Mode 2 functions are indicated on the **TEMPO** display by a small “u” in the leftmost digit position. The number of the function is displayed by the center digit (“1” through “6”), and the function is indicated by the right digit.

The [MIDI/TRANSPOSE] button must be held until after you’ve executed the function, below.

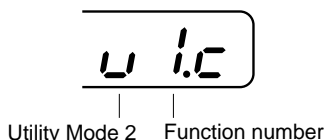

- *You can cancel the selected function at this point and exit from the utility mode simply by releasing the [MIDI/TRANSPOSE] button.*

## 2 Execute as Required

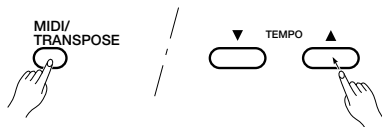

Use the **TEMPO** [▲] or [▼] button while still holding the [MIDI/TRANSPOSE] button to execute the function (the “u 6” function uses other buttons).

## 3 Release the [MIDI/TRANSPOSE] Button to Exit

Release the [MIDI/TRANSPOSE] button to exit from the Utility 2 Mode when you’ve finished making the required settings.

## u i: Clavinova Common Voice Conversion

This function can be used to convert the performance memory voice assignments used by the CVP-87A, CVP-85A, and CVP-83S to Clavinova Common Voice Assignments so songs recorded on one of these instruments can be played back on other Clavinovas.

### 1 Insert the Disk and Select a Song

Insert the disk containing the data to be converted into the Clavinova disk drive and select the song to be converted. This function cannot be executed if an appropriate disk is not loaded (see “Notes” below).

### 2 Select and Execute the Conversion Function

Select the “u i” function as described in the introduction to this section, then, while still holding the [MIDI/TRANSPOSE] button, press the **TEMPO** [▲] or [▼] button to begin conversion. Simply release the [MIDI/TRANSPOSE] button before pressing the **TEMPO** [▲] or [▼] button if you want to cancel the function. You can release the [MIDI/TRANSPOSE] button once the conversion has started, and the conversion will continue to completion.

The Common Voice Conversion function will automatically be exited when the conversion is complete.



- *This function cannot be used to convert the voice data on Disk Orchestra Collection, Disklavier, Style, Standard MIDI File, write-protected, or already-converted disks.*
- *Once converted, the data cannot be returned to its original form. It is therefore a good idea to make a backup copy of the data before using this function.*
- *Some Clavinova models may not have the required voices or different voices will be used so the sound may not be exactly the same as the original.*



## U2: Save Panel Settings

---

This function saves the current settings of all panel controls to disk. The data can then be reloaded at any time by using the Load Panel Settings function (U3), described next.

### 1 Insert the Disk and Select a Song Number .....

Make sure that a properly formatted disk is loaded in the Clavinova disk drive and select the song number you want to save the data to. Panel settings can be saved to a blank song number or one that already contains performance memory data.

### 2 Select and Execute the Function .....

Select the “U2” function as described in the introduction to this section, then, while still holding the [MIDI/TRANSPOSE] button, press the TEMPO [▲] or [▼] button to begin saving the panel settings. Simply release the [MIDI/TRANSPOSE] button before pressing the TEMPO [▲] or [▼] button if you want to cancel the function.

The panel settings are saved to one song file on the disk. The Save Panel Settings function will automatically be exited when the data has been saved.

## U3: Load Panel Settings

---

This function reloads the panel settings saved to disk by the Save Panel Settings function (U2), described above.

### 1 Insert the Disk and Select a Song Number .....

Make sure that the disk containing the saved panel settings is loaded in the Clavinova disk drive and select the song number you want to load the data from.

### 2 Select and Execute the Function .....

Select the “U3” function as described in the introduction to this section, then, while still holding the [MIDI/TRANSPOSE] button, press the TEMPO [▲] or [▼] button to begin loading the panel settings. Simply release the [MIDI/TRANSPOSE] button before pressing the TEMPO [▲] or [▼] button if you want to cancel the function.

The Load Panel Settings function will automatically be exited when the data has been loaded.

## U4: Save Individual Key Tuning

---

This function saves the current individual key tuning data set up via the Utility Mode 1 “Individual Key Tuning” function (U3) to disk. The data can then be reloaded at any time by using the Load Individual Key Tuning function (U5), described next.

### 1 Insert the Disk and Select a Song Number .....

Make sure that a properly formatted disk is loaded in the Clavinova disk drive and select the song number you want to save the data to. Individual key tuning data can be saved to a blank song number or one that already contains performance memory data.

### 2 Select and Execute the Function .....

Select the “U4” function as described in the introduction to this section, then, while still holding the [MIDI/TRANSPOSE] button, press the TEMPO [▲] or [▼] button to begin saving the tuning settings. Simply release the [MIDI/TRANSPOSE] button before pressing the TEMPO [▲] or [▼] button if you want to cancel the function.

The tuning settings are saved to one song file on the disk. The Save Individual Key Tuning function will automatically be exited when the data has been saved.



## U5: Load Individual Key Tuning

This function reloads the individual key tuning data saved to disk by the Save Individual Key Tuning function (U4), described above.

### 1 Insert the Disk and Select a Song Number

Make sure that the disk containing the saved tuning data is loaded in the Clavinova disk drive and select the song number you want to load the data from.

### 2 Select and Execute the Function

Select the “U5” function as described in the introduction to this section, then, while still holding the [MIDI/TRANSCOPE] button, press the TEMPO [▲] or [▼] button to begin loading the tuning data. Simply release the [MIDI/TRANSCOPE] button before pressing the TEMPO [▲] or [▼] button if you want to cancel the function.

The Load Individual Key Tuning function will automatically be exited when the data has been loaded. The Individual Key Tuning function (U3) will then be automatically engaged with the loaded tuning, unless the loaded data is the same as that currently in the Clavinova.

## U6: Quantize Song Data

This function “quantizes” song memory data that has already been recorded to disk. This means that all notes are aligned to the nearest specified beat, thereby “tightening up” the overall timing.

### 1 Insert the Disk and Select a Song

Make sure that the disk containing the song you want to quantize is loaded in the Clavinova disk drive, and that the song to be quantized is selected.

### 2 Select the Quantize Function

Select the “U6” function as described in the introduction to this section.

### 3 Select the Quantize Value

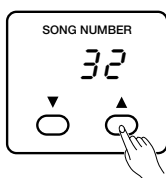

While still holding the [MIDI/TRANSCOPE] button, use the SONG NUMBER [▲] and [▼] buttons to select the desired quantize value, as shown on the SONG NUMBER display:

FFF: “Free”. No quantization.

32: All notes aligned to the nearest 32nd note.

16: All notes aligned to the nearest 16th note.

8: All notes aligned to the nearest 8th note.

24: All notes aligned to the nearest 16th note triplet.

12: All notes aligned to the nearest 8th note triplet.

6: All notes aligned to the nearest quarter note triplet.



### 4 Select a Track

Still holding the [MIDI/TRANSCOPE] button, use the [RIGHT/1TR], [LEFT/2TR], or [ORCH/3-10TR] and [▲]/[▼] buttons to select the track you want to quantize.

### 5 Quantize the Data

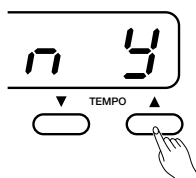

Still holding the [MIDI/TRANSCOPE] button, press the TEMPO [▲] button to begin quantization or the [▼] button to cancel. The Quantize Song Data function will automatically be exited when the data has been quantized.



- Once quantized, song data cannot be returned to its original “free” form. It is therefore a good idea to make a backup copy of the data before using this function.
- Only song data created by the CVP-87A, CVP-85A, or CVP-83S can be quantized. Data converted by the Clavinova Common Voice Conversion function (page 44) cannot be quantized.
- Only note and voice data is quantized.

MIDI, the Musical Instrument Digital Interface, is a world-standard communication interface that allows MIDI-compatible musical instruments and equipment to share musical information and control one another. This makes it possible to create “systems” of MIDI instruments and equipment that offer far greater versatility and control than is available with isolated instruments.

The Clavinova has 11 MIDI functions that are accessed by pressing the appropriate VOICE selector while holding the [MIDI/TRANSCOPE] button. The MIDI functions accessed by the various VOICE selectors are shown in the following chart:

Function	Selector
1. Send Channel Select	PIANO
2. Receive Channel Select	CLAVINOVA TONE
3. Local ON/OFF	E. PIANO
4. Program Change ON/OFF	HARPSI
5. Control Change ON/OFF	VIBES
6. Multi-Timbre Mode ON/OFF	GUITAR
7. Split Send Mode	STRINGS
8. MIDI Clock Select	ORGAN
9. Panel Data Transmit	CHOIR
10. MIDI Transpose Transmit	UPRIGHT BASS
11. Clavinova Common Voice Mode ON/OFF	ELEC BASS

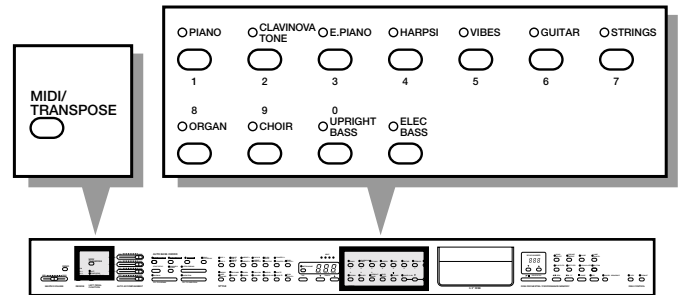

The available settings and procedure for each MIDI function are described below.

**NOTES**

- Always use a high-quality MIDI cable to connect MIDI OUT to MIDI IN terminals. Never use MIDI cables longer than about 15 meters, since cables longer than this can pick up noise which can cause data errors.
- When using the Clavinova with other MIDI equipment, always refer to the MIDI specifications (implementation chart and MIDI data format) of the equipment used to ensure compatibility.

## Send and Receive Channel Select

In any MIDI control setup, the MIDI channels of the transmitting and receiving equipment must be matched for proper data transfer (there are 16 MIDI channels). An “OMNI” receive mode is also available, which allows reception on all 16 MIDI channels. In the OMNI mode it is not necessary to match the receive channel of the receiving device to the transmit channel of the transmitting device.

5 91 ..... 5 16

Send channel

r 91 ..... r 16

Receive channel

ALL

OMNI ON

- 1 Hold [MIDI/TRANSCOPE] and press [PIANO] to set the send channel or [CLAVINOVA TONE] to set the receive channel.
- 2 Use TEMPO [▲] and [▼] buttons to select the desired channel (the selected channel number is shown on the TEMPO display — the OMNI ON receive mode is indicated by “ALL” on the display).
- 3 Release [MIDI/TRANSCOPE].

**NOTES**

- When the power is initially turned ON, MIDI receive is set to the OMNI ON mode and the transmit channel is set to 1.



## Local Control ON/OFF

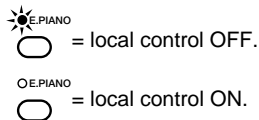
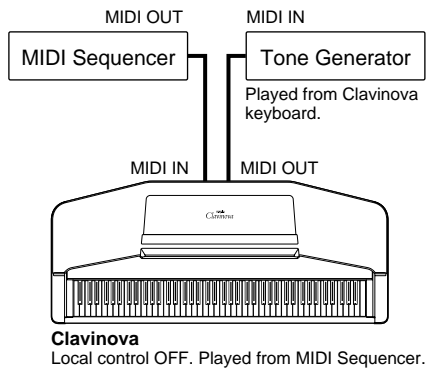

“Local Control” refers to the fact that, normally, the Clavinova keyboard controls its internal tone generator, allowing the internal voices to be played directly from the keyboard. This situation is “Local Control ON” since the internal tone generator is controlled locally by its own keyboard.

Local control can be turned off, however, so that the Clavinova keyboard does not play the internal voices, but the appropriate MIDI information is still transmitted via the MIDI OUT connector when notes are played on the keyboard. At the same time, the internal tone generator responds to MIDI information received via the MIDI IN connector. This means that while an external MIDI sequencer, for example, plays the Clavinova’s internal voices, an external tone generator can be played from the Clavinova keyboard. Local Control is automatically turned ON when the power is initially turned on.

**1** Hold [MIDI/TRANSCOPE] and press [E. PIANO].

**2** Release [MIDI/TRANSCOPE].

## Program Change ON/OFF

Normally the Clavinova will respond to MIDI program change numbers received from an external keyboard or other MIDI device, causing the correspondingly numbered Clavinova voice to be selected. The Clavinova will normally also send a MIDI program change number whenever one of its voices is selected, causing the correspondingly numbered voice or program to be selected on the external MIDI device if the device is set up to receive and respond to MIDI program change numbers.

This function makes it possible to cancel program change number reception and transmission so that voices can be selected on the Clavinova without affecting the external MIDI device, and vice versa. Program Change is automatically turned on when the power is initially turned on.

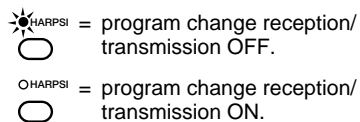

**1** Hold [MIDI/TRANSCOPE] and press [HARPSI].

**2** Release [MIDI/TRANSCOPE].

## Control Change ON/OFF

Normally the Clavinova will respond to MIDI control change data received from an external MIDI device or keyboard, causing the selected Clavinova voice to be affected by pedal and other “control” settings received from the controlling device. The Clavinova also transmits MIDI control change information when either of its pedals are operated.

This function makes it possible to cancel control change data reception and transmission if you do not want the Clavinova voices to be affected by control change data received from an external device or vice versa. Control Change is automatically turned on when the power is initially turned on.

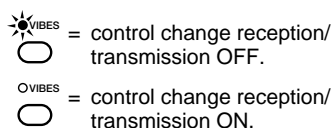

**1** Hold [MIDI/TRANSCOPE] and press [VIBES].

**2** Release [MIDI/TRANSCOPE].



## ■ The Multi-Timbre Mode

The Multi-Timbre mode is a special mode in which the Clavinova voices can be independently controlled on different MIDI channel numbers (1 through 15) by an external MIDI device. The Multi-Timbre mode is off when the power is initially turned on.

The Multi-Timbre mode can be activated as follows:

 = Multi-Timbre mode ON.

**1** Hold [MIDI/TRANPOSE] and press [GUITAR].

 = Multi-Timbre mode OFF.

**2** Release [MIDI/TRANPOSE].

In this mode MIDI program change numbers received by the Clavinova select the corresponding Clavinova voices — i.e. the same voices selected by the panel controls. The Clavinova Common Voice Mode described on page 50 also allows multi-timbre control of the Clavinova, but with different voice assignments.

### ● Rhythm Instrument Note Assignments

The Clavinova's rhythm instruments are controlled via MIDI channel 15. The note assignments for the various rhythm instruments are given below:

Note (MIDI Note No.)	Instrument	Note (MIDI Note No.)	Instrument	Note (MIDI Note No.)	Instrument
A1 (45)	CYMBAL DAMP	D4 (74)	TOM 3	F#5 (90)	CLAVES
F#2 (54)	BRUSH ROLL	D#4 (75)	HI-HAT OPEN	G5 (91)	TIMBALE HIGH
G#2 (56)	HI-HAT CLOSED HEAVY	E4 (76)	TOM 2	G#5 (92)	CASTANETS
A#2 (58)	CRASH CYMBAL LIGHT	F4 (77)	TOM 1	A5 (93)	CUICA LOW
B2 (59)	BASS DRUM LIGHT	F#4 (78)	RIDE CYMBAL NORMAL	A#5 (94)	COWBELL
C3 (60)	SNARE DRUM + RIM HEAVY	G4 (79)	ELECTRIC TOM 3	B5 (95)	CUICA HIGH
C#3 (61)	RIDE CYMBAL CUP	G#4 (80)	CRASH CYMBAL NORMAL	C6 (96)	HAND CLAP
D3 (62)	SNARE DRUM + RIM LIGHT	A4 (81)	ELECTRIC TOM 2	C#6 (97)	AGOGO LOW
F3 (65)	BASS DRUM NORMAL	A#4 (82)	CRASH CYMBAL	D#6 (99)	AGOGO HIGH
F#3 (66)	RIM SHOT	B4 (83)	ELECTRIC TOM 1	E6 (100)	BONGO LOW
G3 (67)	SNARE DRUM HEAVY	C5 (84)	CONGA LOW	F6 (101)	CUICA LOW
G#3 (68)	BRUSH SHOT	C#5 (85)	CABASA	F#6 (102)	TAMBOURINE
A3 (69)	SNARE DRUM LIGHT	D5 (86)	CONGA HIGH	G6 (103)	CRASH CYMBAL
A#3 (70)	HI-HAT PEDAL	D#5 (87)	METRONOME	G#6 (104)	TRIANGLE CLOSED
B3 (71)	SNARE DRUM ECHO	E5 (88)	BONGO HIGH	A6 (105)	BRUSH ROLL
C4 (72)	TOM 4	F5 (89)	TIMBALE LOW	A#6 (106)	TRIANGLE OPEN
C#4 (73)	HI-HAT CLOSED NORMAL				

## ■ The Split Send Mode

In the split send mode notes played on the left-hand section of the keyboard (to the left of and including the split point key — see “Changing the Split Point” on page 10) are transmitted on MIDI channel 2, while the upper keyboard section transmits on the MIDI channel set using the Send Channel Select function described earlier. In this mode the left- and right-hand sections of the keyboard can be used to play separate external keyboards or tone generators set to receive on the appropriate channels. The Split Send Mode is automatically turned off when the power is initially turned on.

 = Split Send Mode ON.

**1** Hold [MIDI/TRANPOSE] and press [STRINGS].

 = Split Send Mode OFF.

**2** Release [MIDI/TRANPOSE].



## ■ MIDI Clock Select

This function determines whether the Clavinova's rhythm and ABC timing is controlled by the Clavinova's own internal clock or an external MIDI clock signal received from external equipment connected to the MIDI IN connector. The Clock Mode is automatically set to INTERNAL when the power is initially turned on.

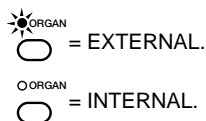

**1** Hold [MIDI/TRANSCOPE] and press the [ORGAN].

**2** Release [MIDI/TRANSCOPE].



• If the Clock Mode is set to EXTERNAL and a MIDI clock signal is not being received from an external source, the rhythm, ABC and other clock-dependent features will not operate.

## ■ Panel Data Send

This function causes all the current Clavinova panel settings (selected voice, etc) to be transmitted via the MIDI OUT connector. This is particularly useful if you will be recording performances to a MIDI sequence recorder which will be used to control the Clavinova on playback. By transmitting the Clavinova panel settings and recording them on the MIDI sequence recorder prior to the actual performance data, the Clavinova will be automatically restored to the same settings when the performance is played back.

**1** Hold [MIDI/TRANSCOPE] and press [CHOIR].

**2** Release [MIDI/TRANSCOPE].

## ■ MIDI Transpose Transmit

This function transposes the pitch of transmitted MIDI note data up or down in semitone intervals up to a maximum of six semitones. The pitch of notes played on the keyboard is not affected.

Display	Transposition
♭ - 6	-6 semitones
♭ - 5	-5 semitones
♭ - 4	-4 semitones
♭ - 3	-3 semitones
♭ - 2	-2 semitones
♭ - 1	-1 semitone
♭ 0	Normal
♭ 1	+1 semitone
♭ 2	+2 semitones
♭ 3	+3 semitones
♭ 4	+4 semitones
♭ 5	+5 semitones
♭ 6	+6 semitones

**1** Hold [MIDI/TRANSCOPE] and press [UPRIGHT BASS].

**2** Use the TEMPO [▲] and [▼] buttons to select the desired degree of transposition while holding the [MIDI/TRANSCOPE] button.

The amount of transposition selected is shown on the TEMPO display.

**3** Release [MIDI/TRANSCOPE].

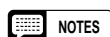

• Press the TEMPO [▲] and [▼] buttons simultaneously while holding the [MIDI/TRANSCOPE] button to restore normal transmitted pitch.

• Transpose is always set to Normal when the power is turned on.

## ■ The Clavinova Common Voice Mode

This mode is similar to the Multi-Timbre Mode described on page 49, but MIDI program change numbers received on all channels are converted to Yamaha Clavinova Common Voice Numbers. MIDI program change numbers transmitted when the panel voice selectors are operated are also converted to the common voice numbers.

The Clavinova Common Voice mode is always off when the power is initially turned on. It can be activated as follows:

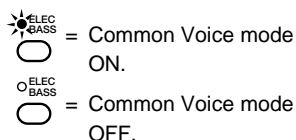

**1** Hold [MIDI/TRANSCOPE] and press [ELEC BASS].

**2** Release [MIDI/TRANSCOPE].



• The panel voices you play on the keyboard are not converted to the Clavinova Common Voices in this mode.

Although the Clavinova is a self-contained musical instrument that simply be plugged into the AC mains outlet and played, it also features a number of connectors for system expansion.

● **OPTIONAL IN L and R Jacks** (CVP-87A & CVP-85A) .....

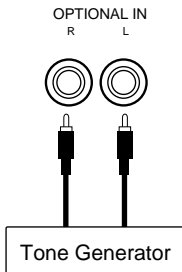

These jacks are intended primarily for use with external synthesizers or tone generator modules.

For example, the outputs of the synthesizer/tone generator can be to the Clavinova **OPTIONAL IN** jacks, allowing the sound of the synthesizer/tone generator to be reproduced via the Clavinova's internal amplifier and speaker system.



NOTES

- The input signal from the **OPTIONAL IN** jacks is delivered to the **AUX. OUT** jacks, but is not affected by the Clavinova's volume control or reverb effect.

● **AUX. OUT L/L+R and R Jacks** (CVP-87A & CVP-85A) .....

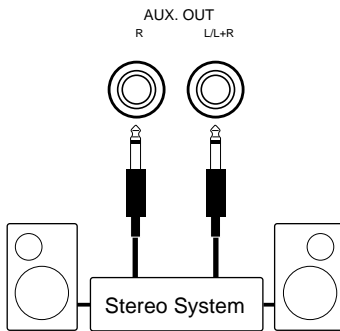

The **AUX. OUT L/L+R** and **R** jacks deliver the output of the Clavinova for connection to an instrument amplifier, mixing console, PA system, or recording equipment. If you will be connecting the Clavinova to a monaural sound system, use only the **L/L+R** jack. When a plug is inserted into the **L/L+R** jack only, the left- and right-channel signals are combined and delivered via the **L/L+R** jack so you don't lose any of the Clavinova's sound.



CAUTION

- The **AUX. OUT** jack signal must never be returned to the **OPTIONAL IN** jacks, either directly or through external equipment.

● **MIDI IN, THRU and OUT Connectors** (MIDI IN and OUT on the CVP-83S) .....

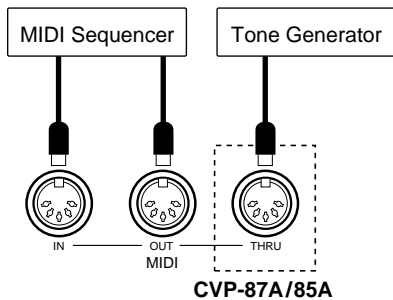

The **MIDI IN** connector receives MIDI data from an external MIDI device (such as a synthesizer, sequencer, music computer, etc.) which can be used to control the Clavinova. The **MIDI THRU** connector provided on the CVP-87A and CVP-85A re-transmits any data received at the **MIDI IN** connector, allowing "chaining" of several MIDI instruments or other devices. The **MIDI OUT** connector transmits MIDI data generated by the Clavinova (e.g. note and velocity data produced by playing the Clavinova keyboard).

More details on MIDI are given in "MIDI Functions" on page 47.

● **EXP. PEDAL Jack** (CVP-87A) .....

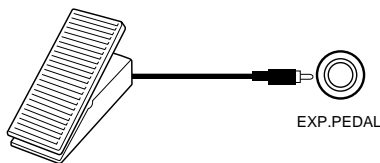

An optional Yamaha EP-1 Expression Pedal can be connected to this jack to allow foot expression (swell) control.



If you encounter what appears to be a malfunction, please check the following points before assuming that your Clavinova is faulty.

## 1. No Sound When the Power is Turned On

Is the AC plug properly connected to an AC wall outlet? Check the AC connection carefully. Is the **MASTER VOLUME** control turned up to a reasonable listening level?

## 2. No Rhythm, ABC, or Performance Memory Sound

Check the Auto Accompaniment volume control settings. No sound is produced if these are set to their minimum positions.

## 3. The Clavinova Reproduces Radio or TV Sound

This can occur if there is a high-power transmitter in your vicinity. Contact your Yamaha dealer.

## 4. Intermittent Static Noise

This is usually due to turning on or off a household appliance or other electronic equipment which is fed by the same AC mains line as your Clavinova.

## 5. Interference Appears On Radio or TV Sets Located Near the Clavinova

The Clavinova contains digital circuitry which can generate radio-frequency noise. The solution is to move the Clavinova further away from the affected equipment, or vice versa.

## 6. Distorted Sound When the Clavinova is Connected to An External Amplifier/Speaker System

If the Clavinova is connected to a stereo system or instrument amplifier and the sound is distorted, reduce the setting of the Clavinova volume control to a level at which the distortion ceases.

# Options

### ● BC-8 Bench

A stable, comfortable bench styled to match your Yamaha Clavinova.

### ● HPE-160 Stereo Headphones

High-performance lightweight dynamic headphones with extra-soft ear pads.

### ● KC-883 Key Cover for the CVP-83S

A convenient way to keep your keyboard clean and dust-free.



NOTES

• Some items may not be available in certain areas.



<b>A</b>			
A-B repeat .....	29		
ABC, recording with .....	33		
Accompaniment volume mode .....	42		
Auto accompaniment volume controls .....	5		
Auto Bass Chord .....	20		
Auto synchro start switching .....	43		
Aux. out jacks .....	51		
<b>B</b>			
Balance, dual mode .....	9		
Balance, split mode .....	11		
<b>C</b>			
Center pedal .....	14		
Chord sequence .....	37		
Chord types .....	21		
Clavinova common voice conversion .....	44		
Clavinova common voice mode .....	50		
Connectors .....	51		
Control change on/off .....	48		
Conventional Full-keyboard ABC .....	22		
Copying songs .....	39		
<b>D</b>			
Damper pedal .....	14		
Damper pedal mode .....	43		
Damper pedal, split mode .....	11		
Delayed wait .....	28		
Deleting a song .....	40		
Demonstration playback .....	6		
Depth control, reverb .....	12		
Disk control .....	38		
Disk orchestra automatic performance .....	26		
Disk orchestra collection disk copy .....	30, 39		
Disk orchestra playback part selection .....	27		
Disk style list .....	24		
Disk styles .....	23		
Drum and percussion key assignments .....	8		
Dual mode .....	9		
<b>E</b>			
Erasing tracks .....	34		
Error messages .....	40		
ESEQ data files .....	30		
Expression pedal .....	5		
Expression pedal jack .....	51		
<b>F</b>			
Fill-ins .....	19		
Fingered accompaniment .....	21		
Floppy disk handling .....	1		
Formatting a disk .....	38		
Full-keyboard ABC .....	22		
<b>G</b>			
General MIDI data files .....	30		
Guide modes .....	28		
Guided right- and left-hand practice .....	28		
<b>H</b>			
Harmonization, Solo Styleplay .....	25		
Headphones .....	4		
<b>I</b>			
Individual key tuning .....	42		
Individual key tuning, load .....	46		
Individual key tuning, save .....	45		
Initial parameter values, changing .....	34		
Internal amplifier and speaker system .....	5		
Introductions .....	18		
<b>K</b>			
Key cover .....	4		
Keyboard .....	13		
Keyboard percussion .....	8		
<b>L</b>			
Left pedal .....	14		
Left pedal, Solo Styleplay .....	25		
Local control on/off .....	48		
<b>M</b>			
Metronome .....	19		
MIDI clock select .....	50		
MIDI connectors .....	51		
MIDI functions .....	47		
MIDI transpose transmit .....	50		
Minor harmonization .....	22, 43		
Monitoring tracks .....	34		
Multi-timbre mode .....	49		
Multi-timbre recording via MIDI .....	36		
Music stand .....	4		
Mute .....	22, 43		
<b>N</b>			
Normal wait .....	28		
<b>O</b>			
Octave shift .....	43		
Optional in jacks .....	51		
Options .....	52		
<b>P</b>			
Pan .....	15		
Panel controls .....	2		
Panel data send .....	50		
Panel settings, save/load .....	45		
Parameters, performance memory .....	33		
Pause .....	30		
Pedal pause/next phrase .....	30		
Pedals .....	14		
Performance memory .....	31		
Phrase repeat .....	29		
Pitch control .....	16		
Playback controls .....	30		
Playback, performance memory .....	36		
Polyphony .....	13		
Power switch .....	4		
Precautions .....	1		
Program change on/off .....	48		
Punch-in recording .....	35		
<b>Q</b>			
Quantize song data .....	46		
<b>R</b>			
Random all song repeat .....	43		
Recording and playback, multitrack .....	32		
Recording and playback, one pass .....	31		
Repeat functions .....	29		
Reverb .....	12		
Rewind and fast forward .....	30		
Rhythm instrument MIDI note assignments .....	49		
Rhythm, recording with .....	33		
<b>S</b>			
Send/receive channel select .....	47		
Single-finger accompaniment .....	20		
Soft pedal .....	14		
Solo styleplay .....	25		
Solo styleplay, recording with .....	33		
Song number selection .....	26, 31		
Sostenuto pedal .....	14		
Split mode .....	10		
Split point, ABC .....	22		
Split point, normal .....	10		
Split send mode .....	49		
Split voices, changing .....	10		
Standard MIDI file playback mode .....	43		
Starting the accompaniment .....	18		
Stopping the accompaniment .....	19		
Style disk, copying .....	39		
Style tempo switching .....	42		
Style selection .....	17		
Synchronized start .....	18		
<b>T</b>			
Tap start .....	19		
Tempo control .....	17		
Touch sensitivity .....	41		
Track selection .....	33		
Tracks, adding new .....	34		
Transposition .....	15		
Troubleshooting .....	52		
<b>U</b>			
Utility mode 1 .....	41		
Utility mode 2 .....	44		
<b>V</b>			
Voice list .....	8		
Voice selection .....	7		
Volume controls .....	5, 22, 28		



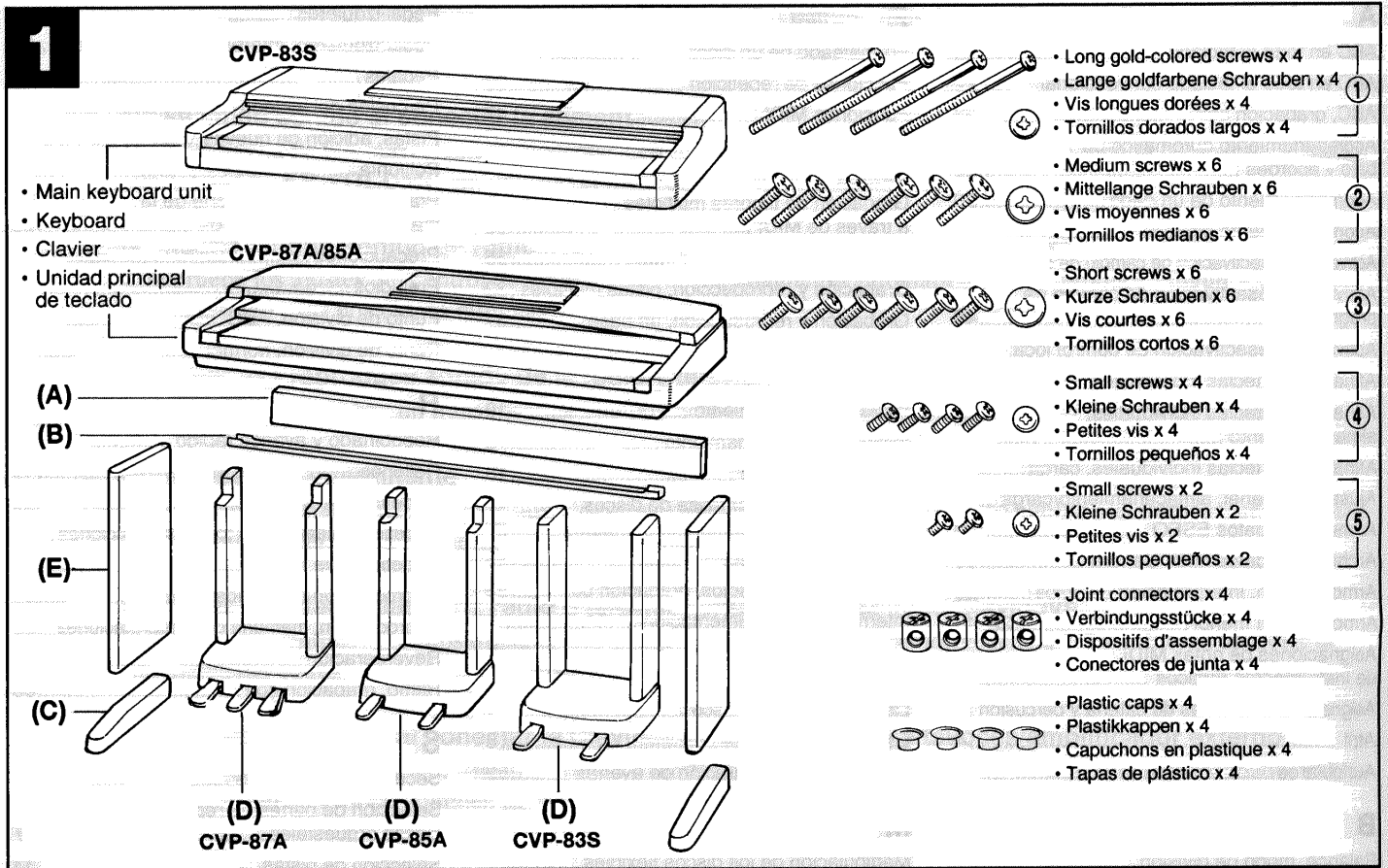

# Assembly

**NOTES** • We do not recommend attempting to assemble the Clavinova alone. The job can be easily accomplished, however, with only two people.

**1** Open the box and remove all the parts.  
On opening the box you should find the parts shown in the illustration. Check to make sure that all the required parts are provided.

**2** Assemble the side panels (E) and feet (C).  
Install the joint connectors in side panels (E) as shown in the illustration, then secure the feet (C) to the side panels (E) with the long gold-colored screws ①. Once secure, push in the plastic caps provided.

\* When installing the joint connectors in the holes in the side panels (E), make sure that they are rotated to the position shown in the illustration.

**3** Attach the side panels (E) to the center panel (A).  
Attach the center panel (A) to the side panels (E) using the four medium screws ② as shown in the illustration.

# Zusammenbau

**HINWEIS** • Wir raten Ihnen davon ab, das Instrument alleine zusammenzubauen. Zwei Personen können das Clavinova jedoch problemlos im Handumdrehen aufstellen.

**1** Den Karton öffnen und die Teile auspacken.  
Der Karton sollte die abgebildeten Teile enthalten. Vergewissern Sie sich, daß alle benötigten Teile vollzählig vorhanden sind.

**2** Die Standbeine (E) und die Füße (C) zusammenschrauben.  
Befestigen Sie die Verbindungsstücke wie in der Abbildung in den Standbeinen (E), und schrauben Sie danach die Füße (C) mit den langen goldfarbenen Schrauben ① gut an den Standbeinen (E) fest. Bringen Sie dann die Plastikkappen an.

\* Beim Einsetzen der Verbindungsstücke in die Standbeine (E) sicherstellen, daß sie in die Position gedreht sind, wie in der Abbildung gezeigt.

**3** Die Standbeine (E) mit dem Auflagebrett (A) verschrauben.  
Schrauben Sie das Auflagebrett (A) mit den vier mittellangen Schrauben ② an den Standbeinen (E) fest, wie in der Abbildung gezeigt.

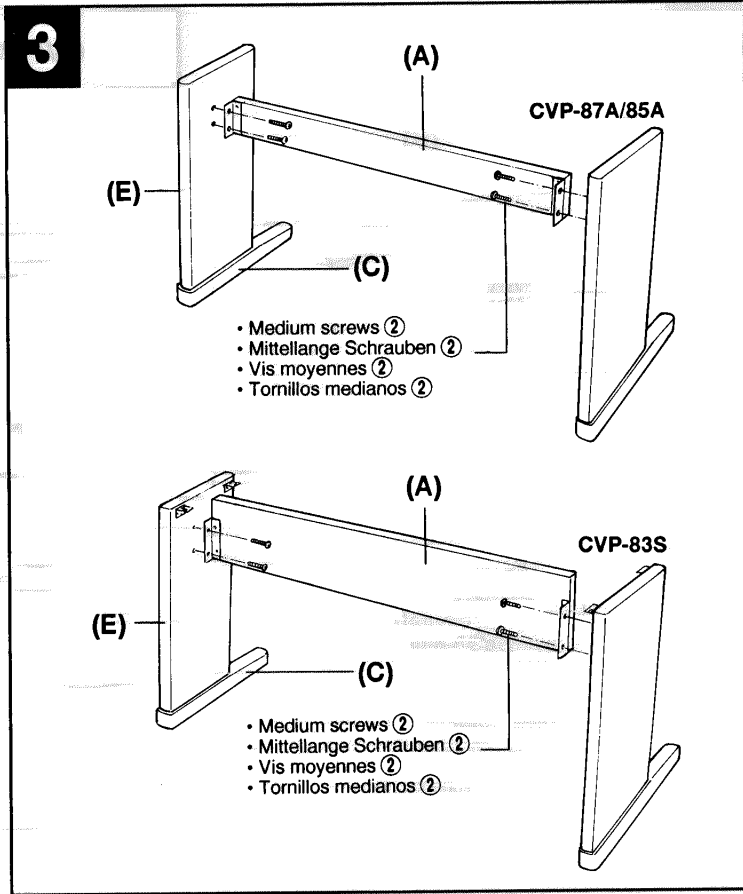
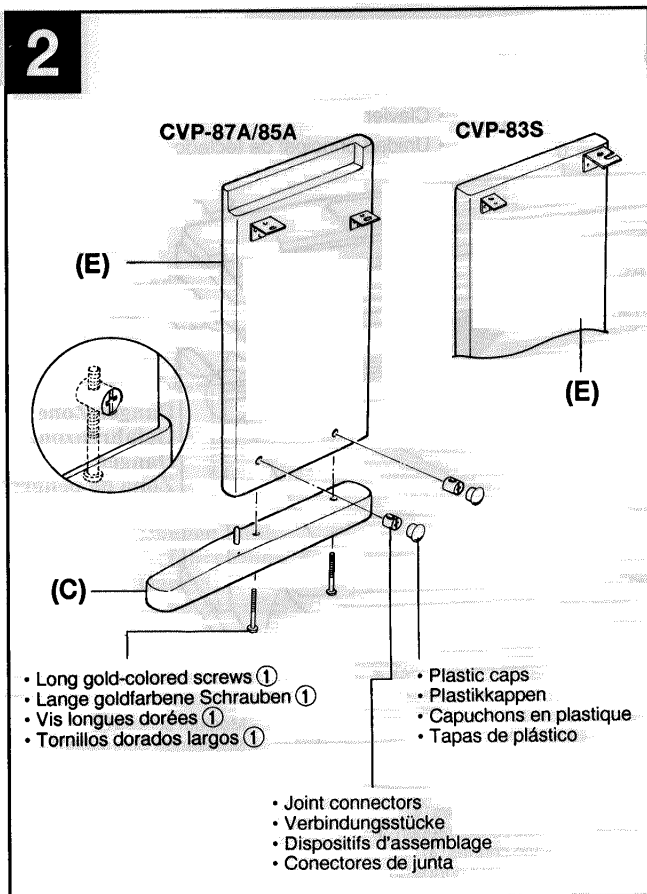

## Montage

REMARQUE

• Nous ne vous conseillons pas d'essayer d'assembler le Clavinova seul. Toutefois, ce travail peut être facilement exécuté par deux personnes.

### 1 Ouvrez le carton et retirez toutes les pièces

Les pièces indiquées sur l'illustration devraient toutes se trouver dans le carton. Vérifiez qu'il n'en manque aucune.

### 2 Montez les panneaux latéraux (E) sur les pieds (C)

Posez les dispositifs d'assemblage sur les panneaux latéraux (E) de la manière illustrée, puis fixez les pieds (C) aux panneaux latéraux (E) à l'aide des vis longues dorées ①. Une fois les vis posées, placez les capuchons en plastique fournis.

\* Lors de la pose des dispositifs d'assemblage dans les trous des panneaux latéraux (E), veillez à bien les diriger dans le sens indiqué sur l'illustration.

### 3 Fixez les panneaux latéraux (E) au panneau central (A)

Fixez le panneau central (A) sur les panneaux latéraux (E) à l'aide de quatre vis moyennes ② comme illustré.

## Montaje

NOTA

• No recomendamos el montaje de la Clavinova por una sola persona. El trabajo puede realizarse fácilmente con dos personas solamente.

### 1 Abra la caja y saque las partes.

Al abrir la caja deberá encontrar las partes mostradas en la ilustración. Compruebe para asegurarse que están todas las partes incluidas.

### 2 Monte los paneles laterales (E) y las patas (C).

Instale los conectores de junta en los paneles laterales (E) como se muestra en la ilustración, después fije las patas (C) en los paneles laterales (E) con los tornillos dorados largos ①. Una vez instalados, introduzca a presión las tapas de plástico proporcionadas.

\* Al instalar los conectores de junta en los orificios de los paneles laterales (E), asegúrese de girarlos hacia la posición mostrada en la ilustración.

### 3 Instale los paneles laterales (E) en el panel central (A).

Instale el panel central (A) en los paneles laterales (E) usando los cuatro tornillos medianos ② como se muestra en la ilustración.

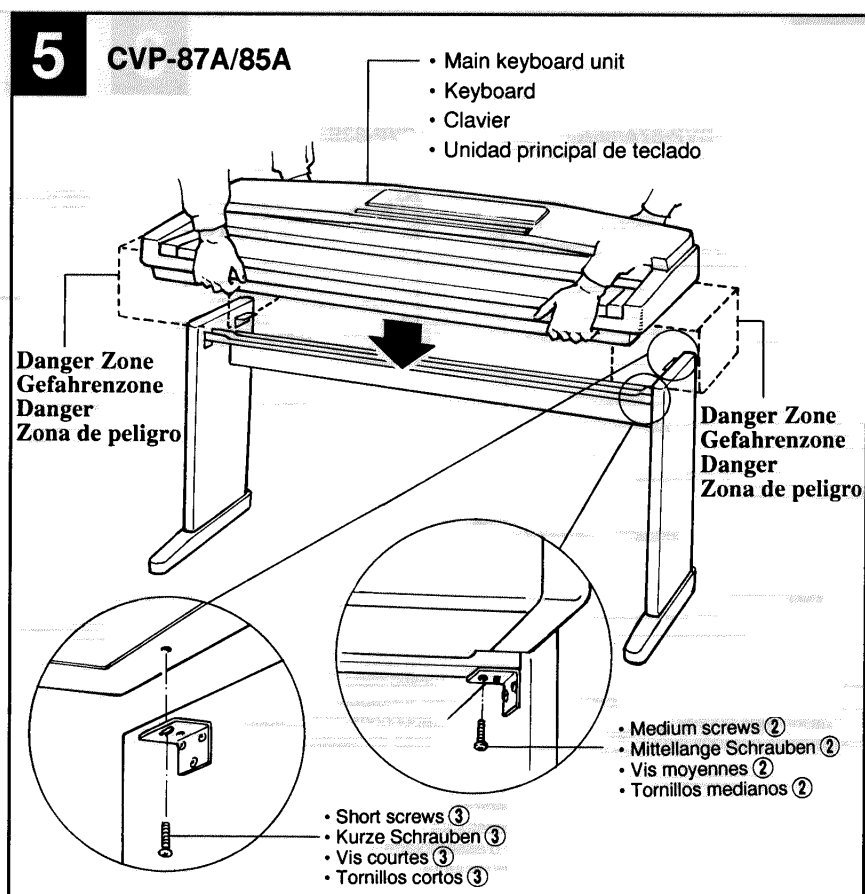
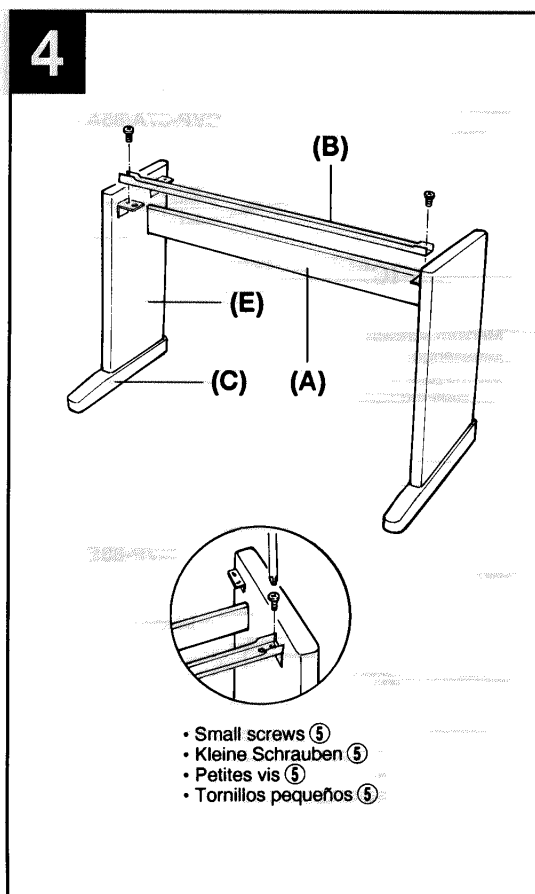

#### 4 Attach front bracket (B) between side panels (E).

Attach the long black metal bracket (B) to the corresponding brackets on the side panels using two short screws ⑤, as shown in the illustration. The flanged edges of bracket (B) should face upwards.

#### 5 Install the main keyboard unit.

**CVP-87A & CVP-85A:** As shown in the illustration, gently lower the main keyboard unit onto the stand assembly so that the screw holes on the bottom of the keyboard match the holes in the brackets near the rear edge of the side panels (E). Secure the main keyboard unit to the stand assembly using two screws ③ screwed through the rear brackets and two screws ② through the front bracket.

**CVP-83S:** In this model the main unit must first be lowered onto the side panels (E) so that the protruding screw heads on its bottom panel are positioned behind the side-panel brackets (near the open ends of the slots in the brackets). Then slide the main unit forward until the screw heads stop against the end of the slots in the brackets. **WATCH YOUR FINGERS WHEN DOING THIS!** Align the holes in the bottom of the main unit with those in the side-panel brackets, then secure the main keyboard unit to the stand assembly using two screws ③ screwed through the rear brackets and two screws ② through the front bracket.

\* Keep your fingers away from the area marked "Danger Zone" in the illustrations when lowering the main keyboard unit onto the stand assembly.

#### 4 Die Strebe (B) zwischen den Standbeinen (E) anbringen.

Schrauben Sie die lange schwarze Metallstrebe (B) an den beiden kurzen Schrauben ⑤ an den Halterungen der Standbeine fest. Die Flanschenden der Strebe (B) müssen dabei nach oben weisen.

#### 5 Die Haupteinheit montieren.

**CVP-87A bzw. CVP-85A:** Setzen Sie die Haupteinheit, wie in der Abbildung gezeigt, vorsichtig so auf den zusammengebauten Ständer, daß die Schraubenbohrungen an ihrer Unterseite mit den Schraubenlöchern der Halterungen an der Innenseite der Standbeine (E) zur Deckung kommen. Schrauben Sie die Haupteinheit dann mit zwei Schrauben ③ an den hinteren Halterungen und zwei weiteren Schrauben ② an der vorderen Halterung fest.

**CVP-83S:** Bei diesem Modell muß die Haupteinheit so auf die Standbeine (E) gesetzt werden, daß die vorstehenden Schraubenköpfe an der Unterseite hinter den Halterungen (am offenen Ende der Halterungsschlitze) der Standbeine zu liegen kommen. Schieben Sie die Haupteinheit dann nach vorn, so daß die Schrauben bis zum Anschlag in den Schlitzen der Halterungen sitzen. **VORSICHT! KLEMMEN SIE SICH DABEI NICHT DIE FINGER EIN!** Bringen Sie nun die Schraubenbohrungen an der Unterseite der Haupteinheit mit den Schraubenlöchern in den Halterungen der Standbeine zur Deckung, und schrauben Sie die Haupteinheit dann mit zwei Schrauben ③ an den hinteren Halterungen und zwei weiteren Schrauben ② an der vorderen Halterung fest.

\* Halten Sie beim Aufsetzen der Haupteinheit auf den Ständer Ihre Finger von dem in der Abbildung mit "Gefahrenzone" gekennzeichneten Bereich fern.

5

CVP-83S

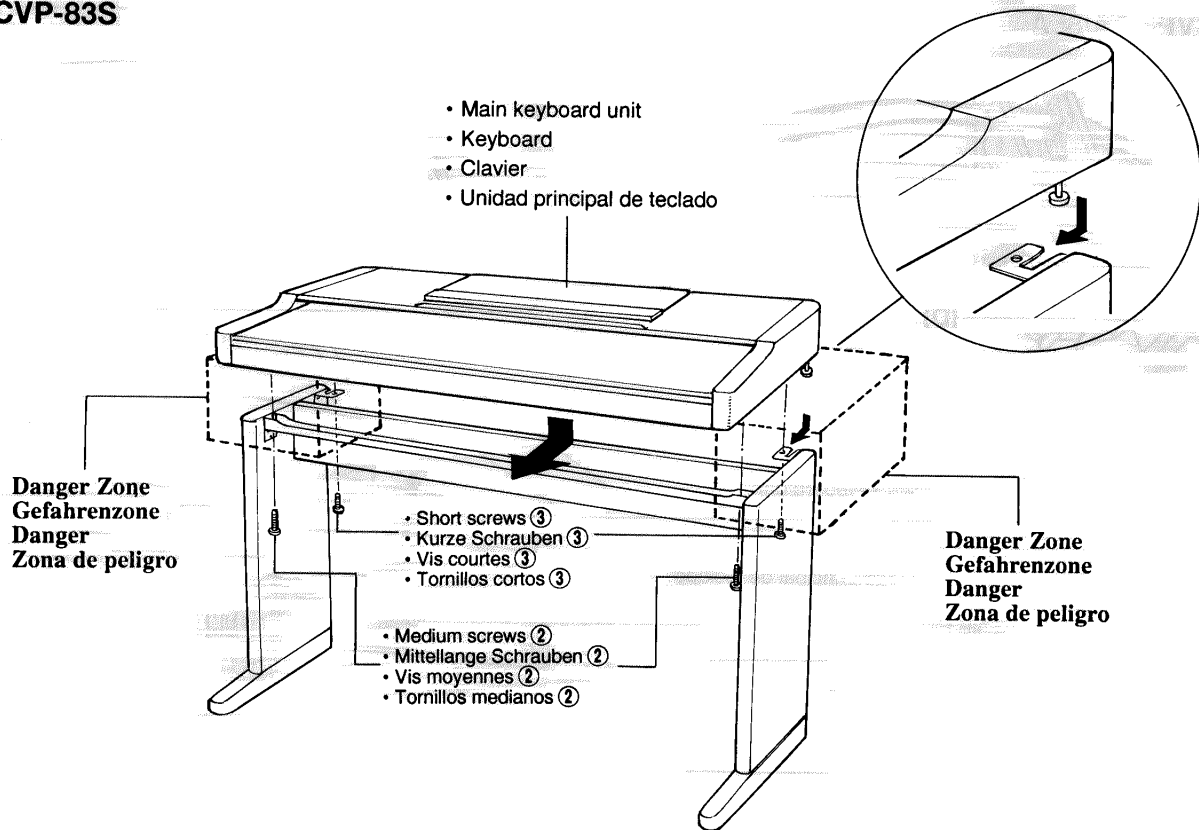

**4 Fixez les supports avant (B) entre les panneaux latéraux (E)**

Fixez de la manière illustrée les quatre supports métalliques longs de couleur noire (B) aux ferrures correspondantes des panneaux latéraux à l'aide de deux vis courtes ⑤. Le bord recourbé des supports (B) doit être dirigé vers le haut.

**5 Posez le clavier**

**CVP-87A et CVP-85A :** Posez le clavier de la manière illustrée, en l'abaissant avec précaution sur l'ensemble et en veillant à ce que les orifices pour vis situés sous le clavier viennent se placer sur les orifices des supports situés près du bord arrière des panneaux latéraux (E). Fixez le clavier aux supports arrière à l'aide de deux vis ③ et au support avant à l'aide de deux vis ②.

**CVP-83S :** Dans le cas de ce modèle, le clavier doit d'abord être abaissé sur les panneau latéraux (E) de manière que les têtes de vis sortant du panneau inférieur soient positionnées derrière les supports des panneau latéraux (à proximité du bords ouvert de la rainure des supports). Faites ensuite glisser le clavier vers l'avant jusqu'à ce que la tête des vis s'arrête contre le fond de la rainure des supports. **FAITES TRES ATTENTION DE NE PAS VOUS PINCER LES DOIGTS!** Alignez les trous à la partie inférieure du clavier sur les trous des supports latéraux et posez deux vis ③ à travers les supports arrière et deux vis ② à travers le support avant.

\* Pour abaisser le clavier sur l'ensemble, ne le tenez pas aux endroits marqués "Danger Zone" sur l'illustration.

**4 Instale la ménsula frontale (B) entre los paneles laterales (E).**

Instale la ménsula métálica negra y larga (B) en las ménsulas correspondientes de los paneles laterales usando dos tornillos cortos ⑤ como se muestra en la ilustración. Los rebordes con brida de la ménsula (B) deben encararse hacia arriba.

**5 Instale la unidad del teclado principal.**

**CVP-87A y CVP-85A:** Como se muestra en la ilustración, baje con cuidado la unidad del teclado principal en el conjunto del soporte de forma que los orificios de tornillo de la parte inferior del teclado se correspondan con los orificios de las ménsulas cerca del borde trasero de los paneles laterales (E). Fije la unidad del teclado principal en el conjunto del soporte usando dos tornillos ③ enroscándolos a través de las ménsulas traseras y dos tornillos ② a través de la ménsula frontal.

**CVP-83S:** En este modelo la unidad principal debe bajarse primero en los paneles laterales (E) de forma que las cabezas de los tornillos salientes de su panel inferior queden colocadas detrás de las ménsulas del panel lateral (cerca de los extremos abiertos de las ranuras de las ménsulas). Después deslice la unidad principal hacia adelante hasta que las cabezas de tornillo se paren contra el extremo de las ranuras de las ménsulas. **¡CUIDADO CON SUS DEDOS CUANDO LO HAGA!** Alinee los orificios de la parte inferior de la unidad principal con los de las ménsulas del panel lateral, después fije la unidad del teclado principal en el conjunto del soporte usando dos tornillos ③ enroscados a través de las ménsulas traseras y dos tornillos ② a través de la ménsula frontal.

\* Mantenga los dedos alejados del área marcada "Zona peligrosa" de las ilustraciones al bajar la unidad del teclado inferior en el conjunto del soporte.

6

CVP-87A/85A

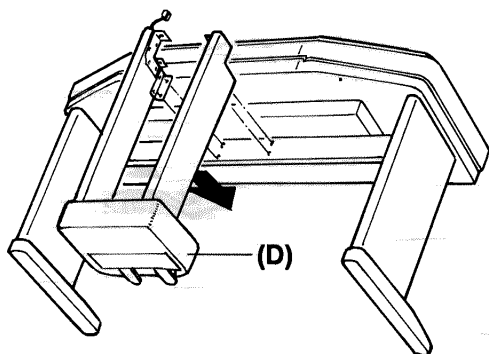

- Main keyboard unit
- Keyboard
- Clavier
- Unidad principal de teclado

- Small screws ④
- Kleine Schrauben ④
- Petites vis ④
- Tornillos pequeños ④

- Short screws ③
- Kurze Schrauben ③
- Vis courtes ③
- Tornillos cortos ③

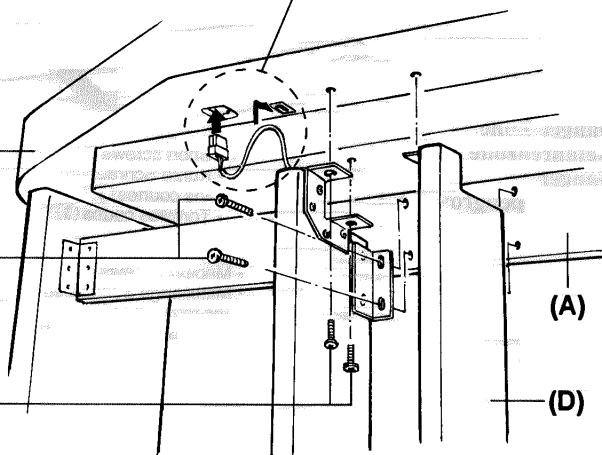
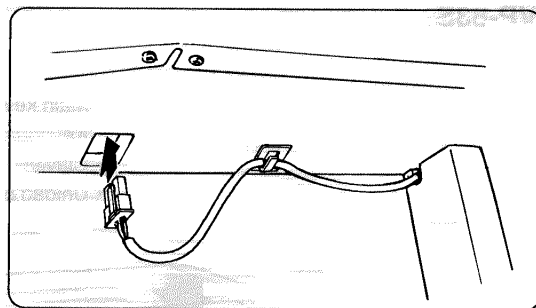

## 6 Attach the pedal assembly.

Tilt the main unit as shown in the illustration, align the pedal assembly with the screw holes on the main unit and center panel (A), making sure that the pedal cord passes through the recess in the top of the pedal assembly, and screw the four screws ④ into the center panel (A), and the four screws ③ into the main keyboard unit.

Plug the pedal cord connector which is protruding from the top of the pedal assembly into the corresponding connector in the bottom of the main keyboard unit. Note that on the CVP-87A and CVP-85A the connector must be inserted with the protruding clip facing the right end of the keyboard (as seen from the keyboard side) while on the CVP-83S the clip faces the rear of the main unit. Clip the slack section of the cord into the cord holder provided.

\* Check to make sure that all screws have been securely tightened.

## 7 Be sure to set the pedal adjusters.

For stability, two adjusters are provided on the bottom of the pedal assembly (D). Rotate the adjusters until they come in firm contact with the floor surface. The adjusters ensure stable pedal operation and facilitate pedal effect control.

\* If the adjusters are not in firm contact with the floor surface, distorted sound may result.

## 6 Den Pedalkasten montieren.

Kippen Sie die Haupteinheit, wie in der Abbildung gezeigt, und setzen Sie den Pedalkasten dabei so an, daß seine Schraubenbohrungen mit denen der Haupteinheit und des Auflagebretts (A) zur Deckung kommen (das Pedalkabel muß dabei durch die Vertiefung an der Oberseite der Pedalkastenbaugruppe nach hinten verlegt werden). Schrauben Sie den Pedalkasten mit vier Schrauben ④ am Auflagebrett und vier weiteren Schrauben ③ an der Haupteinheit fest.

Schließen Sie den aus der Pedalkastenbaugruppe ragenden Pedalkabelstecker an die Buchse an der Unterseite der Haupteinheit an. Beim CVP-87A bzw. CVP-85A wird der Stecker mit dem vorstehenden Clip nach rechts (von der Tastatur aus gesehen) angeschlossen, während der Clip beim CVP-83S nach hinten weisen muß. Wickeln Sie überlanges Kabel auf den dafür vorgesehenen Kabelhalter.

\* Vergewissern Sie sich noch einmal, daß alle Schrauben fest angezogen sind.

## 7 Die Pedalstützen richtig einstellen.

Zur Stabilisierung sind an der Unterseite des Pedalkastens (D) zwei verstellbare Stützen vorgesehen. Schrauben Sie die Stützen heraus, bis sie fest auf dem Boden stehen. Die Stützen sorgen beim Spielen für präzise Pedalbetätigung.

\* Wenn die Stützen nicht fest auf dem Boden aufsitzen, können Klangverzerrungen auftreten.

**6 CVP-83S**

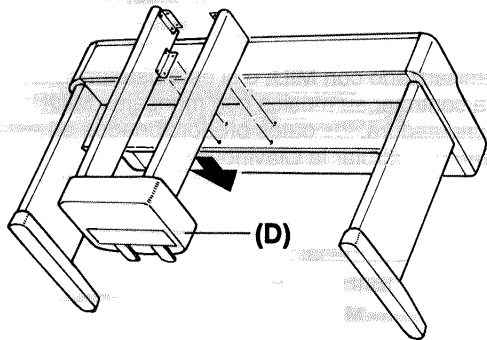

- Main keyboard unit
- Keyboard
- Clavier
- Unidad principal de teclado

- Small screws ④
- Kleine Schrauben ④
- Petites vis ④
- Tornillos pequeños ④

- Short screws ③
- Kurze Schrauben ③
- Vis courtes ③
- Tornillos cortos ③

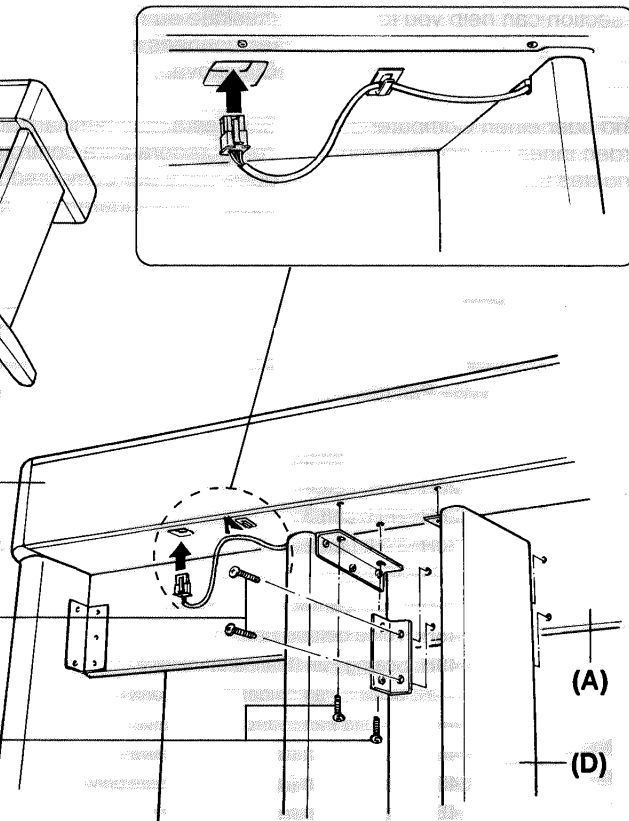

**7**

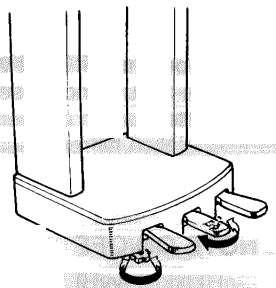

**CVP-87A**

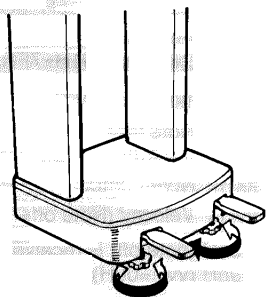

**CVP-85A/83S**

**6 Posez le pédalier**

Inclinez le clavier de la manière illustrée et alignez le pédalier sur les trous de vis du clavier et du panneau central (A) en faisant très attention de faire passer le cordon du pédalier à travers la partie en creux à la partie supérieure du pédalier et visser ensuite quatre vis ④ dans le panneau central (A) et quatre vis ③ dans le clavier.

Brancher le connecteur du cordon de pédale, sortant de la partie supérieure du pédalier, au connecteur correspondant situé à la partie inférieure du clavier. Veuillez noter que dans le cas du CVP-87A et du CVP-85A, le connecteur doit être branché avec la griffe de retenue en saillie dirigée vers le côté droit du clavier (vu de l'avant du clavier), alors que dans le cas du CVP-83S, elle doit être dirigée vers l'arrière du clavier. Attacher la partie du cordon excédentaire à l'aide de l'attache fourni.

\* Vérifiez que toutes les vis sont serrées à fond.

**7 N'oubliez pas de régler la hauteur du pédalier**

Deux dispositifs de réglage sont prévus à la partie inférieure du pédalier (D) pour assurer sa stabilité. Tournez-les jusqu'à ce qu'ils soient en contact ferme avec la surface du sol. Ces dispositifs assurent la stabilité du pédalier lors de son utilisation et facilitent la commande au pied des effets.

\* Si ces dispositifs ne sont pas en contact ferme avec le sol, il pourra se produire une distorsion du son.

**6 Instale el conjunto de pedal.**

Incline la unidad principal como se muestra en la ilustración, alinee el conjunto de pedal con los orificios de tornillo de la unidad principal y el panel central (A), asegurándose de que el cable del pedal pasa a través del entrante de la parte superior del conjunto de pedales y enrosque los cuatro tornillos ④ en el panel central (A) y los cuatro tornillos ③ en la unidad del teclado principal.

Enchufe el conector del cable del pedal que sobresale desde la parte superior del conjunto de pedal en el conector correspondiente de la parte inferior de la unidad del teclado principal. Tenga en cuenta que en la CVP-87A y CVP-85A el conector debe insertarse con el retenedor saliente hacia el extremo derecho del teclado (visto desde el lado del teclado) mientras que en la CVP-83S el retenedor ha de estar encariado hacia la parte posterior de la unidad principal. Sujete la sección sobrante del cable en el soporte proporcionado.

\* Compruebe para asegurarse de que todos los tornillos se han apretado bien.

**7 Asegúrese de ajustar los ajustadores de pedal.**

Para estabilidad, se proporcionan dos ajustadores en la parte inferior del conjunto de pedal (D). Gire los ajustadores hasta que contacten firmemente con el suelo. Los ajustadores aseguran la operación del pedal estable y facilitan el control del efecto del pedal.

\* Si los ajustadores no contactan firmemente con el suelo, resultará en sonido distorsionado.

If you're already very familiar with MIDI, or are using a computer to control your music hardware with computer-generated MIDI messages, the data provided in this section can help you to control the Clavinova.

## 1. NOTE ON/OFF

[9nH] [kkH] [vvH]

9nH= Note on/off event  
(n= MIDI channel number)

kkH= Note number  
(Transmission: 0FH~72H= D#-1~F#7,  
Reception= 15H~6CH: A-1~C7)

vvH= Velocity  
(Note on= 01H~7FH, Note off= 00H)

[8nH] [kkH] [vvH]

8nH= Note off event  
(n= MIDI channel number)

kkH= Note number (15H~6CH: A-1~C7)

vvH= Velocity (Note off= 00H~7FH)

\* 8nH (note off) is receive only.

9nH (vvH=00H) used for transmission.

## 2. CONTROL CHANGE

[BnH] [ccH] [vvH]

BnH= Control event  
(n= MIDI channel number)

ccH= Control number

vvH= Control value

### • Modulation (Vibrato)

[BnH] [01H] [vvH]

n= MIDI channel number

vvH= Modulation

00H~0FH: Off : AM also off.

10H~1FH: 1 : Voice default AM  
when greater than 10H

20H~2FH: 2

30H~3FH: 3

40H~4FH: 4

50H~5FH: 5

60H~6FH: 6

70H~7FH: 7

\* LFO speed fixed for each voice

### • Volume

[BnH] [07H] [vvH]

n= MIDI channel number

vvH= Volume (00H~7FH)

00H: -∞

6FH: -3dB

7FH: ±0dB

### • Pan

[BnH] [0AH] [vvH]

n= MIDI channel number

vvH= Pan (00H~7FH)

00H~17H: Left 6

18H~1FH: Left 5

20H~27H: Left 4

28H~2FH: Left 3

30H~37H: Left 2

38H~3FH: Left 1

40H~47H: Center

48H: Voice default Pan

49H: Scaling Pan (Standard) (receive only)

4AH: Scaling Pan (Wide) (receive only)

4BH: Scaling Pan (Narrow L) (receive only)

4CH: Scaling Pan (Narrow C) (receive only)

4DH: Scaling Pan (Narrow R) (receive only)

4EH: Scaling Pan (Half L) (receive only)

4FH: Scaling Pan (Half R) (receive only)

50H~57H: Right 1

58H~5FH: Right 2

60H~67H: Right 3

68H~6FH: Right 4

70H~77H: Right 5

78H~7FH: Right 6

### • Expression

[BnH] [0BH] [vvH]

n= MIDI channel number

vvH= Expression (00H~7FH)

00H: -∞

6FH: -3dB

7FH: ±0dB

### • Damper pedal

[BnH] [40H] [vvH]

n= MIDI channel number

vvH= Control value (00H~7FH)

8 levels max. (CVP-87A)

00H~3FH: off (CVP-85A/83S)

40H~7FH: on (CVP-85A/83S)

### • Sostenuto pedal

[BnH] [42H] [vvH]

n= MIDI channel number

vvH= Control value (00H~7FH)

00H~3FH: Off

40H~7FH: On

### • Soft pedal

[BnH] [43H] [vvH]

n= MIDI channel number

vvH= Control value (00H~7FH)

00H~3FH: Off

40H~7FH: On

### • Portamento control

[BnH] [54H] [vvH]

n= MIDI channel number

vvH= Control value (00H~7FH)

15H~6CH: Key Number

### • Reverb depth

[BnH] [5BH] [vvH]

n= MIDI channel number

vvH= Reverb Depth (00H~7FH)

Individually adjustable for each channel.

## 3. MODE MESSAGES (receive only)

[BnH] [ccH] [vvH]

BnH= Control event

(n= MIDI channel number)

ccH= Mode message number

vvH= Mode message value

### • All sound off

[BnH] [78H] [00H]

n= MIDI channel number

### • Reset all controllers

[BnH] [79H] [00H]

n= MIDI channel number

### • Local Control ON/OFF

[BnH] [7AH] [vvH]

n= MIDI channel number

vvH= 00H: Off

7FH: On

### • All notes OFF

[BnH] [7BH] [00H]

n= MIDI channel number

### • OMNI OFF/All notes OFF

[BnH] [7CH] [00H]

n= MIDI channel number





- OMNI ON/All notes OFF  
[BnH] [7DH] [00H]  
n= MIDI channel number

#### 4. REGISTERED/NON-REGISTERED PARAMETER NUMBER

- Data entry  
[BnH] [06H] [mmH]  
[BnH] [26H] [IIH]  
n= MIDI channel number  
mm/II=RPN
- Data inc  
[BnH] [60H] [xxH]  
n= MIDI channel number  
xx= Dummy, RPN
- Data dec  
[BnH] [61H] [xxH]  
n= MIDI channel number  
xx= Dummy, RPN
- Non-registered parameter number  
[BnH] [62H] [IIH]  
[BnH] [63H] [mmH]  
n= MIDI channel number  
\* No parameter is received, but the data is recognized because of RPN reception.
- Registered parameter number  
[BnH] [64H] [IIH]  
[BnH] [65H] [mmH]  
n= MIDI channel number  
IIH= 00H, mmH= 00H: Pitch bend sensitivity  
IIH= 01H, mmH= 00H: Fine tune  
IIH= 02H, mmH= 00H: Coarse tune  
IIH= 7FH, mmH= 7FH: RPN Reset

#### 5. PROGRAM CHANGE

[CnH] [ppH]  
CnH= Program change event  
(n= MIDI channel number)  
ppH= Program number

##### Panel Voices

dd VOICE  
00H PIANO  
01H CLAVINOVA TONE  
02H E. PIANO  
03H HARPSICHOARD  
04H VIBES  
05H GUITAR  
06H STRINGS  
07H ORGAN  
08H CHOIR  
09H UPRIGHT BASS  
0AH E. BASS  
0BH DRUMS

##### Voices 13 — 60

dd VOICE  
0CH BRASS  
0DH POP BRASS  
0EH TRUMPET  
0FH MUTE TRUMPET  
10H HORN  
11H SAX  
12H SAX SOFT  
13H CLARINET  
14H OBOE  
15H FLUTE  
16H ACCORDION  
17H HARMONICA  
18H STRINGS SOFT  
19H VIOLIN  
1AH VIOLIN HARD  
1BH FULL ORGAN  
1CH JAZZ ORGAN 1  
1DH SYNTH BRASS  
1EH SYNTH WOOD  
1FH SYNTH STRINGS  
20H SYNTH CHOIR  
21H PIANO BRIGHT  
22H PIANO SOFT  
23H E. PIANO DX  
24H SYNTH CRYSTAL  
25H CELESTA  
26H MARIMBA  
27H FOLK GUITAR  
28H JAZZ GUITAR 1  
29H JAZZ GUITAR 2  
2AH ROCK GUITAR 1  
2BH ROCK GUITAR 2  
2CH MUTE GUITAR  
2DH BANJO  
2EH PIZZICATO  
2FH HARP  
30H U. BASS SOFT  
31H E. BASS SOFT  
32H E. BASS HEAVY  
33H SYNTH BASS  
34H TIMPANI & ORCH. HIT  
35H BASSOON  
36H CHAMBER STRINGS  
37H JAZZ ORGAN 2  
38H ROCK GUITAR 3  
39H COSMIC 1  
3AH COSMIC 2  
3BH COSMIC 3

#### 6. PITCH BENDER

[EnH] [IIH] [mmH]  
EnH= Bender event  
(n= MIDI channel number)  
IIH= Least significant byte  
mmH= Most significant byte

\* **Caution:** The bend range is set to a minor third when the power is turned on. RPN data can be used to set the range in semitone increments.

#### 7. SYSTEM REALTIME MESSAGES

[rrH]  
F8H: Timing clock  
FAH: Start  
FCH: Stop  
FEH: Active sensing

Data	Transmission	Reception
F8H	Transmitted every 96 clocks	Received as 96-clock tempo timing when MIDI clock is set to External
FAH	Rhythm start	Rhythm start
FCH	Rhythm stop	Rhythm stop
FEH	Transmitted every 200 milliseconds	All notes are turned off if no data is received for more than 400 milliseconds

\* **Caution:** If an overrun framing error occurs the Damper, Sostenuto, and Soft effects for all channels are turned off and an All Note Off occurs.

#### 8. SYSTEM EXCLUSIVE MESSAGES

- YAMAHA MIDI format  
[F0H] [43H] [xnH] [ffH] ..... [F7H]  
43H= YAMAHA ID  
xnH= Substatus + MIDI channel number  
ffH= Format number  
\* n specifies the receive channel regardless of whether omni is on or off.  
x ff Information  
0 7CH Panel data receive  
2 7CH Panel data bulk dump request  
2 7DH Model ID data bulk dump request

##### Panel Data Send Format

F0H, 43H, 0xH, 7CH, 00H, 22H  
(x: channel number,  
data length= Panel data+0cH)  
53H, 4BH, 20 H, 20H (SK)  
43H, 56H, 50H, 27H, 39H, 33H (CVP'93)  
3xH, 3yH (Version x, y)  
[Panel Data]  
[Check Sum (1byte)]= 0  
(53H+4BH+20H+...  
...+Data end)  
F7H

##### [Panel Data Contents]

- (1) ABC ON/OFF
- (2) SSP ON/OFF
- (3) SSP NO.
- (4) MANUAL VOICE
- (5) MANUAL VOLUME
- (6) RHYTHM NO.
- (7) RHYTHM VARIATION
- (8) TEMPO (Absolute value LSB)
- (9) TEMPO (Absolute value MSB)
- (10) RHYTHM VOLUME
- (11) CHORD 1 VOLUME
- (12) CHORD 2 VOLUME
- (13) BASS VOLUME

- (14) SPLIT POINT
- (15) DUAL/SPLIT MODE
- (16) DUAL/SPLIT VOICE
- (17) DUAL/SPLIT BALANCE
- (18) REVERB
- (19) REVERB DEPTH
- (20) PEDAL FUNCTION
- (21) VOICE BANK (Upper 4 bits)
- (22) INTRO

#### Individual Key Tuning Data Bulk Dump Format

F0H, 43H, 73H  
 34H (Product ID: CVP-87A/85A/83S)  
 06H (Bulk ID)  
 00H (Bulk No.)  
 00H, 00H, 0bH, 00H (Data Length= wxyH  
 88\*2 bytes)  
 [BULK DATA] (low (A-1), high (A-1)  
 ...low (C7), high (C7))  
 [CHECK SUM (1byte)]= 0-sum  
 (BULK DATA)

#### Name Data Send Format

F0H, 43H, 0xH, 7DH, 00H, 10H  
 (Data Length= 10H  
 byte)  
 53H, 4BH, 20H, 20H (SK)  
 43H, 56H, 50H, 27H, 39H, 33H (CVP'93)  
 3xH, 3yH, 20H, 20H, 20H, 20H (Version x.y)  
 [CHECK SUM (1byte)]= 0-(53H+4BH+20H+...  
 ...+20H)  
 F7H

#### • Clavinova MIDI Format

[F0H] [43H] [73H] [yyH] [xxH] [F7H]  
 43H= YAMAHA ID  
 73H= CLAVINOVA ID  
 yyH= Product ID (CVP-87A/85A/83S= 34H)  
 xxH= Substatus  
 xxH Information  
 02H Internal MIDI clock  
 03H External MIDI clock  
 13H Multi-timbre mode off  
 14H Common voice multi-timbre mode on  
 15H Multi-timbre mode on  
 18H Common voice multi-timbre mode  
 individual track reverb depth on  
 7nH All Note Off,  
 Receive Channel = n+1, Omni off

\* When nn = 2, 3, 13, 14, 15, 18, or 7C,  
 Clavinova common ID (01H) is recognized  
 as well as 34H.

\* All Control Change values are reset when  
 [13H], [14H] or [15H] is received. All  
 voices and other parameters are also  
 reset when [14H] or [15H] is received in  
 order to ensure the same initial settings.

#### • Special Messages

[F0H] [43H] [73H] [yyH] [11H] [0nH]  
 [ccH] [vvH] [F7H]  
 43H= YAMAHA ID  
 73H= CLAVINOVA ID  
 yyH= Product ID (CVP-87A/85A/83S= 34H)  
 11H= Clavinova Special Control Code  
 0nH= Control MIDI Change  
 (n= special control change number)  
 ccH= Control number  
 ddH= Control value

cc	Control	Value [dd]
08H	DUAL/SPLIT Balance	00H= lower MAX 7FH= upper MAX
10H	ABC Mode	00H= Off 01H= ABC Single Finger 02H= ABC Fingering 03H= Full-Keyboard ABC 04H= New Full-Keyboard (IAS)
11H	Rhythm Variation	00H= Off 01H= Variation number
12H	Fill In Switch Event	00H= Fill to normal Off event 01H= Fill to normal On event 02H= Fill to variation On event 03H= Fill to variation Off event
13H	Intro/Ending Switch Event	00H= Intro/Ending Off 01H= Intro mode On 02H= Ending mode On 03H= Fill to normal mode On 04H= Fill to variation mode On
14H	Split	[ddH]= Split key number (the highest note in the left-hand keyboard range)
15H	Rhythm Number	[ddH]= Rhythm number
19H	Volume	[ddH]= Volume value n= 2 (BASS) 4 (CHORD 1) 5 (CHORD 2)
1AH	Rhythm Volume	[ddH]= Volume value
1BH	Metronome mode (receive only)	00H: Off 01H: On
21H	Solo Styleplay Number	00~17H= Style number
22H	Solo Styleplay	00H~3FH= Off 40H~7FH= On
30H	Drums Parameter Change	See Drum Parameter Expanded Format, below
59H	Reverb	00H= Off 01H= Room 02H= Hall 1 03H= Hall 2

04H= Cosmic  
 5AH Dual/Split mode 00H= Off  
 01H= Dual  
 02H= Split (upper damper)  
 03H= Split (lower damper)  
 04H= Split (upper/lower damper)  
 05H= Split & Lower Voice Oct Up (upper damper)  
 06H= Split & Lower Voice Oct Up (lower damper)  
 07H= SPLIT & Lower Voice Oct Up (upper/lower damper)  
 5CH Dual/Split Voice [ddH]= Dual/Split voice number  
 5DH Pedal Function [ddH]= Function number  
 \* When cc = 59 (Reverb), SK common ID (01H) is recognized in addition to xxH.

#### Drum Parameter Expanded Format

[F0H] [43H] [73H] [xxH] [11H] [0nH]  
 [30H] [xxH] .....[F7H]  
 xxH: Product ID;  
 Common product ID also recognized (pattern editor transmits both).  
 0x30: /\* Drum Parameter \*/ \*2 Expanded Format  
 \* This resets all parameters when a different drum kit is selected.  
 Expands Special Message 30.

#### • Effect Level

[F0H] [43H] [73H] [xxH] [11H] [0nH]  
 [30H] [43H] [knH] [enH] [s1H] [F7H]  
 11H: Clavinova special control code  
 0nH: MIDI Channel Number  
 \* Received only on channel 15 (0EH) in the CVP'93, affecting all tracks.  
 Received only on channel 10 (09H) in the GM mode, affecting all tracks.  
 30H: Drums Parameter Change  
 43H: Effect Send Level  
 knH: Key Number  
 \* Also included in the panel key code in the Clavinova Common Voice mode (because conversion is not possible).  
 Included in the GM key code in the GM mode.  
 \* When kn = 01 the en for all keys is set to the default.  
 When kn = 02 the en for all keys is set to s1.  
 enH: Effect Number  
 en= 5B: Reverb Depth  
 s1H: Send Level  
 \* This data applies a ± 40H offset to the CH depth parameter of each channel of

each instrument.

#### Example

[F0H] [43H] [73H] [xxH] [11H] [0eH]  
 [30H] [43H] [knH] [enH] [slH] [F7H]  
 [knH] [enH] [slH]  
 [36H] [5bH] [10H]:  
 F#0 Brush Roll reverb depth set to -30H.  
 [01H] [5bH] [xxH]:  
 Reverb depth for all keys set to default (±0).  
 [02H] [5bH] [20H]:  
 Reverb depth for all keys set to -20H.

#### • Pan Set Switching

[F0H] [43H] [73H] [xxH] [11H] [0nH]  
 [30H] [47H] [knH] [pnH] [F7H]  
 11H: Clavinova special control code  
 0nH: MIDI Channel Number  
 \* Received only on channel 15 (0EH) in  
 the CVP'93, affecting all tracks.  
 Received only on channel 10 (09H) in  
 the GM mode, affecting all tracks.  
 30H: Drums Parameter Change  
 47H: Panpot  
 knH: Key Number  
 \* Also included in the panel key code in  
 the Common Voice mode (because  
 conversion is not possible). Included in  
 the GM key code in the GM mode.  
 \* When kn = 01 pan is set to the value  
 specified in pn.  
 When kn = 02 the pan for all keys is set  
 to the pin point specified in pn.

pnH: Pan

\* When kn = 01 pan is set to the value  
 specified in pn.  
 pn= 00: Normal DOC Setting  
 = 01: Narrow DOC left  
 = 02: Narrow DOC center  
 = 03: Narrow DOC right  
 = 04: Normal GM Setting  
 = 05: Narrow GM left  
 = 06: Narrow GM center  
 = 07: Narrow GM right  
 \* Normal pan value used when kn is other  
 than 01.  
 However, values 48...4F are also set to  
 pin-point center.

#### • Absolute Tempo

[F0H] [43H] [73H] [yyH] [11H] [1nH]  
 [ccH] [ddH] [F7H]  
 43H= YAMAHA ID  
 73H= CLAVINOVA ID  
 yyH= Product ID (CVP-87A/85A/83S= 34H)  
 11H= Clavinova special control code  
 1nH= Control MIDI Change  
 (Transmit: n = Control Change number)  
 (Receive: any channel OK)  
 cc= Absolute tempo low byte  
 dd= Absolute tempo high byte

Tempo= dd\*128+ccH

#### • Beat, Tempo LED ON/OFF

[F0H] [43H] [73H] [yyH] [11H] [4FH]  
 [ccH] [ddH] [F7H]  
 43H= YAMAHA ID  
 73H= CLAVINOVA ID  
 yyH= Product ID  
 (CVP-87A/85A/83S= 34H, or common 01H)  
 11H= Clavinova special control code  
 4FH= Control MIDI Change  
 ccH= 00H: Beat lamp on/off  
 01H: Tempo lamp on/off  
 ddH= 00H: On  
 7FH: Off

• All MIDI data available for general use are  
 given above.

		CVP-87A	CVP-85A	CVP-83S
<b>KEYBOARD</b>		88 KEYS (A-1 — C7)		
<b>tone generator</b>		AWM (Advanced Wave Memory)		
<b>VOICE SELECTORS &amp; CONTROLS</b>		PIANO, CLAVINOVA TONE, E. PIANO, HARPSI, VIBES, GUITAR, STRINGS, ORGAN, CHOIR, UPRIGHT BASS, ELEC BASS, DRUMS, VOICE 13 - 60, ▲/▼, SPLIT		
<b>AUTO BASS CHORD &amp; CONTROLS</b>		FULL KEYBOARD, SINGLE FINGER, FINGERED, SOLO STYLEPLAY, RHYTHM VOLUME, CHORD 1 VOLUME, CHORD 2 VOLUME, BASS VOLUME		
<b>STYLE SELECTORS &amp; CONTROLS</b>		POP 1/2, DANCE POP 1/2, 16 BEAT 1/2, ROCK'N', 16 BEAT SHUFFLE, SLOW ROCK, SHUFFLE, COUNTRY 1/2, SWING, JAZZ BALLAD, BIG BAND, BOOGIE, BOSSA, SAMBA, CHA-CHA, RHUMBA, MARCH, MARCH 6/8, WALTZ, J. WALTZ, DISK STYLE 1/2 START/STOP, SYNCHRO START, INTRO/ENDING, NORMAL/FILL TO NORMAL, VARIATION/ FILL TO VARIATION, TEMPO ▲/▼, TEMPO Display, BEAT LED, TAP, METRONOME		
<b>DISK STYLE</b>		40 styles (refer to page 24)		
<b>KEYBOARD PERCUSSION</b>		44 instruments (refer to page 8)		
<b>REVERB</b>		ROOM, HALL 1, HALL 2, COSMIC		
<b>DISK ORCHESTRA/ PERFORMANCE MEMORY</b>		SONG SELECT, PHRASE REPEAT, GUIDE, LAMP CANCEL (CVP-87A only), RIGHT/1TR, LEFT/2TR, ORCH/3-10TR, RHYTHM, ►/■ START/STOP, ◀◀REW, ►►FF,   PAUSE, REC, CHORD SEQUENCE, SONG NUMBER Display		
<b>DISK DRIVE &amp; CONTROLS</b>		3.5" 2DD Micro Floppy Disk Drive. COPY, FORMAT		
<b>PEDAL CONTROLS</b>	RIGHT	DAMPER		
	CENTER	SOSTENUTO	—	
	LEFT	SOFT (START/STOP, SOLO STYLEPLAY)	SOFT (SOSTENUTO, START/STOP, SOLO STYLEPLAY)	
<b>OTHER CONTROLS</b>		MASTER VOLUME, MIDI/TRANPOSE, DEMO, POWER		
<b>JACKS &amp; CONNECTORS</b>		HEADPHONES x 2, AUX. OUT R and L/L + R, OPTIONAL IN R/L, MIDI IN/OUT/THRU, EXP. PEDAL (CVP-87A only)		HEADPHONES x 2, MIDI IN/OUT
<b>INPUT &amp; OUTPUT LEVEL/IMPEDANCE</b>		AUX. OUT: Output Impedance 600 Ω OPTIONAL IN: Input Impedance 10 kΩ / Input Sensitivity -10dBm		—
<b>MAIN AMPLIFIERS</b>		80 W (40 W x 2)	80 W (40 W x 2)	40 W (20 W x 2)
<b>SPEAKERS</b>		13 cm (5-1/8") x 2, 5 cm (2") x 2	13 cm (5-1/8") x 2, 5 cm (2") x 2	16 cm (6-1/4") x 2, 5 cm (2") x 2
<b>DIMENSIONS</b> (W x D x H)	Music stand down	1416 mm x 582 mm x 831 mm (55-3/4" x 23" x 32-3/4")	1416 mm x 582 mm x 828 mm (55-3/4" x 23" x 32-5/8")	1414 mm x 506 mm x 835 mm (55-5/8" x 20" x 32-7/8")
	Music stand up	1416 mm x 582 mm x 1003 mm (55-3/4" x 23" x 39-1/2")	1416 mm x 582 mm x 998 mm (55-3/4" x 23" x 39-1/4")	1414 mm x 506 mm x 1013 mm (55-5/8" x 20" x 39-7/8")
<b>WEIGHT</b>		64.7 kg (142.6 lbs.)	62.7 kg (138.2 lbs.)	54.0 kg (119 lbs.)

\* Specifications subject to change without notice.

















































# Fingering Chart

\* All fingerings shown are simple root-position types.

	Major	Minor	Seventh	Minor seventh
C		Cm	C7	Cm7
C# (D♭)		C#m (D♭m)	C#7 (D♭7)	C#m7 (D♭m7)
D		Dm	D7	Dm7
D# (E♭)		D#m (E♭m)	D#7 (E♭7)	D#m7 (E♭m7)
E		Em	E7	Em7
F		Fm	F7	Fm7
F# (G♭)		F#m (G♭m)	F#7 (G♭7)	F#m7 (G♭m7)
G		Gm	G7	Gm7
G# (A♭)		G#m (A♭m)	G#7 (A♭7)	G#m7 (A♭m7)
A		Am	A7	Am7
A# (B♭)		A#m (B♭m)	A#7 (B♭7)	A#m7 (B♭m7)
B		Bm	B7	Bm7



Major seventh		Minor major seventh		Augmented		Diminished	
CM <sub>7</sub>		CmM <sub>7</sub>		Caug		Cdim	
C#M <sub>7</sub> (D♭M <sub>7</sub> )		C#mM <sub>7</sub> (D♭mM <sub>7</sub> )		C#aug (D♭aug)		C#dim (D♭dim)	
DM <sub>7</sub>		DmM <sub>7</sub>		Daug		Ddim	
D#M <sub>7</sub> (E♭M <sub>7</sub> )		D#mM <sub>7</sub> (E♭mM <sub>7</sub> )		D#aug (E♭aug)		D#dim (E♭dim)	
EM <sub>7</sub>		EmM <sub>7</sub>		Eaug		Edim	
FM <sub>7</sub>		FmM <sub>7</sub>		Faug		Fdim	
F#M <sub>7</sub> (G♭M <sub>7</sub> )		F#mM <sub>7</sub> (G♭mM <sub>7</sub> )		F#aug (G♭aug)		F#dim (G♭dim)	
GM <sub>7</sub>		GmM <sub>7</sub>		Gaug		Gdim	
G#M <sub>7</sub> (A♭M <sub>7</sub> )		G#mM <sub>7</sub> (A♭mM <sub>7</sub> )		G#aug (A♭aug)		G#dim (A♭dim)	
AM <sub>7</sub>		AmM <sub>7</sub>		Aaug		Adim	
A#M <sub>7</sub> (B♭M <sub>7</sub> )		A#mM <sub>7</sub> (B♭mM <sub>7</sub> )		A#aug (B♭aug)		A#dim (B♭dim)	
BM <sub>7</sub>		BmM <sub>7</sub>		Baug		Bdim	

	Sixth	Suspended fourth	Minor seventh flatted fifth	Major seventh flatted fifth
C6		Csus4 	Cm7-5 	CM7-5 
C#6 (D♭6)		C#sus4 (D♭sus4) 	C#m7-5 (D♭m7-5) 	C#M7-5 (D♭M7-5) 
D6		Dsus4 	Dm7-5 	DM7-5 
D#6 (E♭6)		D#sus4 (E♭sus4) 	D#m7-5 (E♭m7-5) 	D#M7-5 (E♭M7-5) 
E6		Esus4 	Em7-5 	EM7-5 
F6		Fsus4 	Fm7-5 	FM7-5 
F#6 (G♭6)		F#sus4 (G♭sus4) 	F#m7-5 (G♭m7-5) 	F#M7-5 (G♭M7-5) 
G6		Gsus4 	Gm7-5 	GM7-5 
G#6 (A♭6)		G#sus4 (A♭sus4) 	G#m7-5 (A♭m7-5) 	G#M7-5 (A♭M7-5) 
A6		Asus4 	Am7-5 	AM7-5 
A#6 (B♭6)		A#sus4 (B♭sus4) 	A#m7-5 (B♭m7-5) 	A#M7-5 (B♭M7-5) 
B6		Bsus4 	Bm7-5 	BM7-5 



**Half diminished (minor major seventh flatted fifth)**

**Minor sixth**

**Seventh suspended fourth**

**Major flatted fifth**

CmM7-5 	Cm6 	C7sus4 	C-5 
C#mM7-5 (D♭mM7-5) 	C#m6 (D♭m6) 	C#7sus4 (D♭7sus4) 	C#-5 (D♭-5) 
DmM7-5 	Dm6 	D7sus4 	D-5 
D#mM7-5 (E♭mM7-5) 	D#m6 (E♭m6) 	D#7sus4 (E♭7sus4) 	D#-5 (E♭-5) 
EmM7-5 	Em6 	E7sus4 	E-5 
FmM7-5 	Fm6 	F7sus4 	F-5 
F#mM7-5 (G♭mM7-5) 	F#m6 (G♭m6) 	F#7sus4 (G♭7sus4) 	F#-5 (G♭-5) 
GmM7-5 	Gm6 	G7sus4 	G-5 
G#mM7-5 (A♭mM7-5) 	G#m6 (A♭m6) 	G#7sus4 (A♭7sus4) 	G#-5 (A♭-5) 
AmM7-5 	Am6 	A7sus4 	A-5 
A#mM7-5 (B♭mM7-5) 	A#m6 (B♭m6) 	A#7sus4 (B♭7sus4) 	A#-5 (B♭-5) 
BmM7-5 	Bm6 	B7sus4 	B-5 



Minor flatted fifth

Seventh flatted fifth

Seventh sharp fifth

Major seventh sharp fifth

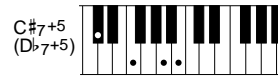
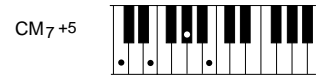

Function	Transmitted	Recognized	Remarks
Basic Default	: 1	: 1	:
Channel Changed	: 1-16	: 1-16	:
Mode Default	: 3	: 1	:
Mode Messages	: X	: OMNIon,OMNIoff	:
	: *****	: X	:
Note	: 15-114	: 21-108	:
Number : True voice	: *****	: 21-108	:
Velocity Note on	: 0 9nH, v=1-127	: 0 v=1-127	:
Note off	: X 9nH, v=0	: X	:
After Key's	: X	: X	:
Touch Ch's	: X	: X	:
Pitch Bender	: 0	: 0	:
Control			
Change			
	01 : 0	: 0	: Modulation
	06, 38 : X	: 0	: Data entry
	07 : 0	: 0	: Volume
	10 : 0	: 0	: Pan pot
	11 : 0	: 0	: Expression
	64 : 0	: 0	: Damper
	66 : 0	: 0	: Sostenuto
	67 : 0	: 0	: Soft
	84 : 0	: 0	: Portament
	91 : 0	: 0	: Reverb depth
	96, 97 : X	: 0	: Data inc/dec
	98, 99, 100, 101 : X	: 0	: NRPN, PRN lsb/msb
	120 : X	: 0	: All sounds off
			: *1
	121 : X	: 0	: Reset all
			: controllers *1
Program	: 0 0-59	: 0 0-127	:
Change : True #	: *****	: 0-127	:
System Exclusive	: 0	: 0	:
System : Song Pos	: X	: X	:
: Song Sel	: X	: X	:
Common : Tune	: X	: X	:
System : Clock	: 0	: 0	:
Real Time: Commands	: 0	: 0	:
Aux : Local ON/OFF	: X	: 0	:
: All Notes OFF	: X	: 0 (123-125) *1	:
Mes- : Active Sense	: 0	: 0	:
sages: Reset	: X	: X	:
Notes : *1 = receive (120,121,123) if omni off or multi-timbre on			:
Mode 1 : OMNI ON, POLY	Mode 2 : OMNI ON, MONO	0 : Yes	
Mode 3 : OMNI OFF, POLY	Mode 4 : OMNI OFF, MONO	X : No	

# FCC INFORMATION (U.S.A.)

## 1. IMPORTANT NOTICE: DO NOT MODIFY THIS UNIT!

This product, when installed as indicated in the instructions contained in this manual, meets FCC requirements. Modifications not expressly approved by Yamaha may void your authority, granted by the FCC, to use the product.

**2. IMPORTANT:** When connecting this product to accessories and/or another product use only high quality shielded cables. Cable/s supplied with this product MUST be used. Follow all installation instructions. Failure to follow instructions could void your FCC authorization to use this product in the USA.

**3. NOTE:** This product has been tested and found to comply with the requirements listed in FCC Regulations, Part 15 for Class "B" digital devices. Compliance with these requirements provides a reasonable level of assurance that your use of this product in a residential environment will not result in harmful interference with other electronic devices. This equipment generates/uses radio frequencies and, if not installed and used according to the instructions found in the users manual, may cause interference harmful to the operation of other

electronic devices. Compliance with FCC regulations does not guarantee that interference will not occur in all installations. If this product is found to be the source of interference, which can be determined by turning the unit "OFF" and "ON", please try to eliminate the problem by using one of the following measures:

Relocate either this product or the device that is being affected by the interference.

Utilize power outlets that are on different branch (circuit breaker or fuse) circuits or install AC line filter/s.

In the case of radio or TV interference, relocate/reorient the antenna. If the antenna lead-in is 300 ohm ribbon lead, change the lead-in to co-axial type cable.

If these corrective measures do not produce satisfactory results, please contact the local retailer authorized to distribute this type of product. If you can not locate the appropriate retailer, please contact Yamaha Corporation of America, Electronic Service Division, 6600 Orangethorpe Ave, Buena Park, CA90620

The above statements apply ONLY to those products distributed by Yamaha Corporation of America or its subsidiaries.

\* This applies only to products distributed by YAMAHA CORPORATION OF AMERICA.

Wichtiger Hinweis für die Benutzung in der Bundesrepublik Deutschland.

## Bescheinigung des Importeurs

Hiermit wird bescheinigt, daß der/die/das

**Electronic Piano Typ: CVP-87A**

(Gerät, Typ, Bezeichnung)

in Übereinstimmung mit den Bestimmungen der

VERFÜGUNG 1046/84

(Amtsblattverfügung)

funk-entstört ist.

Der Deutschen Bundespost wurde das Inverkehrbringen dieses Gerätes angezeigt und die Berechtigung zur Überprüfung der Serie auf Einhaltung der Bestimmungen eingeräumt.

**Yamaha Europa GmbH**

Name des Importeurs

• Dies bezieht sich nur auf die von der Yamaha Europa GmbH vertriebenen Produkte.

## IMPORTANT NOTICE FOR THE UNITED KINGDOM

### Connecting the Plug and Cord

IMPORTANT. The wires in this mains lead are coloured in accordance with the following code:

BLUE : NEUTRAL  
BROWN : LIVE

As the colours of the wires in the mains lead of this apparatus may not correspond with the coloured markings identifying the terminals in your plug proceed as follows:

The wire which is coloured BLUE must be connected to the terminal which is marked with the letter N or coloured BLACK.

The wire which is coloured BROWN must be connected to the terminal which is marked with the letter L or coloured RED.

Making sure that neither core is connected to the earth terminal of the three pin plug.

• This applies only to products distributed by Yamaha-Kemble Music (U.K.) Ltd.

Wichtiger Hinweis für die Benutzung in der Bundesrepublik Deutschland.

## Bescheinigung des Importeurs

Hiermit wird bescheinigt, daß der/die/das

**Electronic Piano Typ: CVP-85A**

(Gerät, Typ, Bezeichnung)

in Übereinstimmung mit den Bestimmungen der

VERFÜGUNG 1046/84

(Amtsblattverfügung)

funk-entstört ist.

Der Deutschen Bundespost wurde das Inverkehrbringen dieses Gerätes angezeigt und die Berechtigung zur Überprüfung der Serie auf Einhaltung der Bestimmungen eingeräumt.

**Yamaha Europa GmbH**

Name des Importeurs

• Dies bezieht sich nur auf die von der Yamaha Europa GmbH vertriebenen Produkte.

## CANADA

THIS DIGITAL APPARATUS DOES NOT EXCEED THE "CLASS B" LIMITS FOR RADIO NOISE EMISSIONS FROM DIGITAL APPARATUS SET OUT IN THE RADIO INTERFERENCE REGULATION OF THE CANADIAN DEPARTMENT OF COMMUNICATIONS.

LE PRESENT APPAREIL NUMERIQUE N'EMET PAS DE BRUITS RADIOELECTRIQUES DEPASSANT LES LIMITES APPLICABLES AUX APPAREILS NUMERIQUES DE LA "CLASSE B" PRESCRITES DANS LE REGLEMENT SUR LE BROUILLAGE RADIOELECTRIQUE EDICTE PAR LE MINISTERE DES COMMUNICATIONS DU CANADA.

**CAUTION:** TO PREVENT ELECTRIC SHOCK, MATCH WIDE BLADE OF PLUG TO WIDE SLOT, FULLY INSERT.

**ATTENTION:** POUR ÉVITER LES CHOCS ÉLECTRIQUES, INTRODUIRE LA LAME LA PLUS LARGE DE LA FICHE DANS LA BORNE CORRESPONDANTE DE LA PRISE ET POUSSER JUSQU'AU FOND.

• This applies only to products distributed by Yamaha Canada Music Ltd.  
• Ceci ne s'applique qu'aux produits distribués par Yamaha Canada Musique Ltée.

Wichtiger Hinweis für die Benutzung in der Bundesrepublik Deutschland.

## Bescheinigung des Importeurs

Hiermit wird bescheinigt, daß der/die/das

**Electronic Piano Typ: CVP-83S**

(Gerät, Typ, Bezeichnung)

in Übereinstimmung mit den Bestimmungen der

VERFÜGUNG 1046/84

(Amtsblattverfügung)

funk-entstört ist.

Der Deutschen Bundespost wurde das Inverkehrbringen dieses Gerätes angezeigt und die Berechtigung zur Überprüfung der Serie auf Einhaltung der Bestimmungen eingeräumt.

**Yamaha Europa GmbH**

Name des Importeurs

• Dies bezieht sich nur auf die von der Yamaha Europa GmbH vertriebenen Produkte.

Dit produkt is gefabriceerd in overeenstemming met de radiostoringsvoorschriften van de Richtlijn van de Raad (82/499/EEG).  
ΑΥΤΗ Η ΣΥΣΚΕΥΗ ΑΝΤΑΠΟΚΡΙΝΕΤΑΙ ΣΤΙΣ ΑΠΑΙΤΗΣΕΙΣ ΤΩΝ ΟΔΗΓΙΩΝ ΤΗΣ ΕΥΡΩΠΑΙΚΗΣ ΟΙΚΟΝΟΜΙΚΗΣ ΚΟΙΝΟΤΗΤΑΣ 82/499/Ε.Ο.Κ..

Este produto está de acordo com o radio de interferencia frequente requeridos do Conselho Diretivo 82/499/EEC.

Dette apparat overholder det gældende EF-direktiv vedrørende radiostøj.  
Cet appareil est conforme aux prescriptions de la directive communautaire 87/308/CEE.

Diese Geräte entsprechen der EG-Richtlinie 82/499/EWG und/oder 87/308/EWG.

This product complies with the radio frequency interference requirements of the Council Directive 82/499/EEC and/or 87/308/EEC.

Questo apparecchio è conforme al D.M.13 aprile 1989 (Direttiva CEE/87/308) sulla soppressione dei radiodisturbi.

Este producto está de acuerdo con los requisitos sobre interferencias de radio frecuencia fijados por el Consejo Directivo 87/308/CEE.

**YAMAHA CORPORATION**

**YAMAHA**  
YAMAHA CORPORATION