

**MUSIC SYNTHESIZER**

# SS90

**Data List  
Daten-Liste  
Liste des données****Table of Contents**

<b>Voice List</b> .....	<b>2</b>
<b>Drum Voice List</b> .....	<b>7</b>
<b>Drum Voice Name List</b> .....	<b>7</b>
<b>Drum Kit Assign List</b> .....	<b>8</b>
<b>Performance List</b> .....	<b>19</b>
<b>Wave List</b> .....	<b>20</b>
<b>Effect Type List</b> .....	<b>22</b>
<b>Effect Parameter List</b> .....	<b>24</b>
<b>Effect Data Assign Table</b> .....	<b>34</b>
<b>Control List</b> .....	<b>36</b>
<b>Arpeggio Type List</b> .....	<b>37</b>
<b>MIDI Data Format</b> .....	<b>38</b>
<b>MIDI Data Table</b> .....	<b>41</b>
<b>MIDI Implementation Chart</b> .....	<b>55</b>

This document is printed on chlorine free (ECF) paper with soy ink.

M.D.G., Pro Audio & Digital Musical Instrument Division, Yamaha Corporation  
© 2002 Yamaha Corporation

V943790 206MWCP3.3-01A0 Printed in Japan

**MODULAR SYNTHESIS  
PLUG-IN SYSTEM**

# Voice List

## PRE1 (MSB 63, LSB 0)

Number	Voice Name	Category	Sub Category	
1	A01	3LayerS700	Ap	A.PIANO
2	A02	Soft Touch	Ap	A.PIANO
3	A03	PowerGrand	Ap	A.PIANO
4	A04	BriteRock	Ap	A.PIANO
5	A05	Jazz Grand	Ap	A.PIANO
6	A06	CP 80	Ap	E.GRAND
7	A07	BalladKeys	Ap	OTHER
8	A08	80's Layer	Ap	OTHER
9	A09	S700&Strg	Ap	OTHER
10	A10	S700&Ooh	Ap	OTHER
11	A11	PianoBakup	Ap	OTHER
12	A12	Max Tine	Kb	E.PIANO
13	A13	Early Fusn	Kb	E.PIANO
14	A14	Vintage'74	Kb	E.PIANO
15	A15	Sweetness	Kb	E.PIANO
16	A16	DynoStrait	Kb	E.PIANO
17	B01	ChorusHard	Kb	E.PIANO
18	B02	VintagCase	Kb	E.PIANO
19	B03	ChorusDyno	Kb	E.PIANO
20	B04	80th Boost	Kb	E.PIANO
21	B05	Contempo	Kb	E.PIANO
22	B06	Early 70's	Kb	E.PIANO
23	B07	Tonight	Kb	E.PIANO
24	B08	E.PianoPad	Kb	OTHER
25	B09	TX802	Kb	E.PIANO
26	B10	ChorusBel	Kb	E.PIANO
27	B11	BellDX	Kb	E.PIANO
28	B12	Dark DX	Kb	E.PIANO
29	B13	GS Tines	Kb	E.PIANO
30	B14	Rich FM	Kb	E.PIANO
31	B15	FilteredDX	Kb	E.PIANO
32	B16	Ice Piano	Kb	OTHER
33	C01	WurliTrem	Kb	E.PIANO
34	C02	WurliAmped	Kb	E.PIANO
35	C03	TouchClavi	Kb	CLAVI
36	C04	SuperClavi	Kb	CLAVI
37	C05	StereoClav	Kb	CLAVI
38	C06	HollowClav	Kb	CLAVI
39	C07	Nu Phasing	Kb	CLAVI
40	C08	Digi Clavi	Kb	CLAVI
41	C09	PulseClavi	Kb	CLAVI
42	C10	Twinkle	Cp	BELL
43	C11	Stick Bell	Cp	BELL
44	C12	Bell Chiff	Cp	BELL
45	C13	FngrCymb	Cp	BELL
46	C14	ChorusBell	Cp	BELL
47	C15	Tibetan	Cp	BELL
48	C16	EastBell	Cp	BELL
49	D01	Gamelan	Cp	BELL
50	D02	IceBells	Cp	BELL
51	D03	Digi Bell	Cp	BELL
52	D04	Marimbell	Cp	MALLET
53	D05	16+8+5&1/3	Or	ELECTRIC
54	D06	Petit	Or	ELECTRIC
55	D07	Glassy	Or	ELECTRIC
56	D08	Jazzy	Or	ELECTRIC
57	D09	Slow Jam	Or	ELECTRIC
58	D10	Greasy	Or	ELECTRIC
59	D11	Swishie	Or	ELECTRIC
60	D12	Clean	Or	ELECTRIC
61	D13	Full/CVib	Or	ELECTRIC
62	D14	Mellow	Or	ELECTRIC
63	D15	Nu Shade	Or	ELECTRIC
64	D16	Cool Cat	Or	ELECTRIC

Number	Voice Name	Category	Sub Category	
65	E01	Flutey	Or	ELECTRIC
66	E02	LeftManual	Or	ELECTRIC
67	E03	DrawContrl	Or	ELECTRIC
68	E04	Rocky	Or	ELECTRIC
69	E05	Expensive	Or	ELECTRIC
70	E06	Progressy	Or	ELECTRIC
71	E07	Crunchy	Or	ELECTRIC
72	E08	Early Bird	Or	ELECTRIC
73	E09	Jazz Split	Or	ELECTRIC
74	E10	GosplSplit	Or	ELECTRIC
75	E11	Tradi	Or	ELECTRIC
76	E12	Sunday	Or	PIPE
77	E13	BreathPipe	Or	PIPE
78	E14	Fluty Pipe	Or	PIPE
79	E15	Reedy Pipe	Or	PIPE
80	E16	OohPipes	Pd	CHOIR
81	F01	Flamenco	Gt	A.GUITAR
82	F02	Nylon Jam	Gt	A.GUITAR
83	F03	BriteSteel	Gt	A.GUITAR
84	F04	Strums	Gt	A.GUITAR
85	F05	Big Steel	Gt	A.GUITAR
86	F06	Folk Steel	Gt	A.GUITAR
87	F07	18 String	Gt	A.GUITAR
88	F18	HarpsiGtr	Gt	A.GUITAR
89	F09	HybridGtr	Gt	A.GUITAR
90	F10	JazzGTmelo	Gt	E.GUITAR
91	F11	Velo Jazz	Gt	E.GUITAR
92	F12	FM Jazz	Gt	E.GUITAR
93	F13	For Funk	Gt	E.GUITAR
94	F14	Spanky	Gt	E.GUITAR
95	F15	Funkiest	Gt	E.GUITAR
96	F16	Vin Strum	Gt	E.GUITAR
97	G01	1CoilChors	Gt	E.GUITAR
98	G02	CleanChors	Gt	E.GUITAR
99	G03	ChorusPlus	Gt	E.GUITAR
100	G04	SmoothChor	Gt	E.GUITAR
101	G05	TexBoogie	Gt	E.GUITAR
102	G06	Rockabilly	Gt	E.GUITAR
103	G07	65 Combo	Gt	E.GUITAR
104	G08	VinTremolo	Gt	E.GUITAR
105	G09	Crunchoid	Gt	E.GUITAR
106	G10	DynamicAmp	Gt	E.GUITAR
107	G11	Feedback	Gt	E.GUITAR
108	G12	VOODOOMAN	Gt	E.GUITAR
109	G13	BlueLead	Gt	E.GUITAR
110	G14	MeloRckLd	Gt	E.GUITAR
111	G15	MetalMute	Gt	E.GUITAR
112	G16	OverTheTop	Gt	E.GUITAR
113	H01	RoundWound	Ba	E.BASS
114	H02	FingerMan	Ba	E.BASS
115	H03	PrecRW	Ba	E.BASS
116	H04	PrecFW	Ba	E.BASS
117	H05	HybridBass	Ba	E.BASS
118	H06	Stand Up	Ba	A.BASS
119	H07	Fretless	Ba	E.BASS
120	H08	Slap&Fx	Ba	E.BASS
121	H09	BriteSlap	Ba	E.BASS
122	H10	Velo Bass	Ba	E.BASS
123	H11	Bs+Cym+Vb	Co	SPLIT
124	H12	Boogie on	Ba	SYNTH
125	H13	MiniDetune	Ba	SYNTH
126	H14	Long Spit	Ba	SYNTH
127	H15	Tack Bass	Ba	SYNTH
128	H16	Fat Octave	Ba	SYNTH

**PRE2 (MSB 63, LSB 1)**

Number	Voice Name	Category	Sub Category
1	A01	Violin	St SOLO
2	A02	Viola	St SOLO
3	A03	Cello	St SOLO
4	A04	SoloSpicat	St SOLO
5	A05	2 Solos	St ENSEMBLE
6	A06	Cello Duet	St ENSEMBLE
7	A07	Trio	St ENSEMBLE
8	A08	Chamber	St ENSEMBLE
9	A09	Small Ens	St ENSEMBLE
10	A10	Medium Ens	St ENSEMBLE
11	A11	Ens Mix	St ENSEMBLE
12	A12	Ensemble	St ENSEMBLE
13	A13	Hard Ens	St ENSEMBLE
14	A14	Background	St ENSEMBLE
15	A15	BigSymphny	St ENSEMBLE
16	A16	Str/Horns	Br SECTION
17	B01	Stringy	St SYNTH
18	B02	Polystring	St SYNTH
19	B03	JP Strings	St SYNTH
20	B04	MournStrgs	St SYNTH
21	B05	The Pizz	St ENSEMBLE
22	B06	Fanfare	Br SECTION
23	B07	Hi Brass	Br SECTION
24	B08	Fat Sect	Br SECTION
25	B09	Sforzando	Br SECTION
26	B10	Symphony	Br SECTION
27	B11	Big Band	Br SECTION
28	B12	Big Band 2	Br SECTION
29	B13	SaxBigBand	Br SECTION
30	B14	MedmBrass	Br SECTION
31	B15	Soft Brass	Br SECTION
32	B16	SoftVeloBr	Br SECTION
33	C01	TrpRomantc	Br SOLO
34	C02	Phase Mute	Br SOLO
35	C03	Legend	Br SOLO
36	C04	Trombone	Br SOLO
37	C05	Flugelleaz	Br SOLO
38	C06	F.Horn Ens	Br SECTION
39	C07	SlowAttack	Br SECTION
40	C08	Strng/Bras	Br SECTION
41	C09	Movie Ens	Br SECTION
42	C10	Powered	Br SYNTH
43	C11	ObStuff	Br SYNTH
44	C12	Prophy	Br SYNTH
45	C13	AnalogBras	Br SYNTH
46	C14	After 1984	Br SYNTH
47	C15	Soprano	Rp SAX/REED
48	C16	Alto Vib	Rp SAX/REED
49	D01	SaxEnsembl	Rp SAX/REED
50	D02	Tenor Sax	Rp SAX/REED
51	D03	Tenor Soft	Rp SAX/REED
52	D04	The Winds	Rp OTHER
53	D05	WindOrch	St ENSEMBLE
54	D06	SweetFlute	Rp PIPE
55	D07	PanBottle	Rp PIPE
56	D08	AmpHarpMW	Rp OTHER
57	D09	SmoothSaw	Ld SOFT
58	D10	Lucky	Ld SOFT
59	D11	Tri Solo	Ld SOFT
60	D12	Syntrump	Ld SOFT
61	D13	PWM Lead	Ld SOFT
62	D14	Clicky Saw	Ld SOFT
63	D15	Mini Pulse	Ld SOFT
64	D16	Sync Lead	Ld HARD

Number	Voice Name	Category	Sub Category
65	E01	Altair	Pd SOFT
66	E02	Analog	Pd SOFT
67	E03	Sweetland	Pd BRIGHT
68	E04	WarmSweepy	Pd BRIGHT
69	E05	SinePad	Pd SOFT
70	E06	Square	Pd SOFT
71	E07	VoxPad	Pd CHOIR
72	E08	Pure Syn	Pd BRIGHT
73	E09	MovingPad	Pd BRIGHT
74	E10	SimpleSaws	Pd SOFT
75	E11	X-Shower	Pd SOFT
76	E12	PWM Pad	Pd SOFT
77	E13	Bell Choir	Pd BRIGHT
78	E14	ObSoft	Pd SOFT
79	E15	MellowAnlg	Pd SOFT
80	E16	Glasschoir	Pd BRIGHT
81	F01	PeaceVox	Pd CHOIR
82	F02	StackChoir	Pd CHOIR
83	F03	Bronx	Pd CHOIR
84	F04	IceChoir	Pd CHOIR
85	F05	Fast Oohs	Pd CHOIR
86	F06	Ooze & OZ	Pd CHOIR
87	F07	NeoCrystal	Pd BRIGHT
88	F18	Pop Synth	Pd BRIGHT
89	F09	Fantasy	Pd SOFT
90	F10	Heavenly	Pd BRIGHT
91	F11	Retro	Pd BRIGHT
92	F12	Airy Nylon	Pd SOFT
93	F13	Antares	Pd BRIGHT
94	F14	Pan Sphere	Pd SOFT
95	F15	Tamburax	Pd BRIGHT
96	F16	IndianFlai	Pd BRIGHT
97	G01	SAKURA	Me MOTION
98	G02	RisingHigh	Me MOTION
99	G03	Champ	Me MOTION
100	G04	Gladiator	Me MOTION
101	G05	Hades	Me MOTION
102	G06	Glacy	Me MOTION
103	G07	Forest	Me MOTION
104	G08	MirrorRing	Me MOTION
105	G09	Poly	Sc HARD
106	G10	AnaTonk	Sc SOFT
107	G11	Jaipur	Gt PLUCK
108	G12	Dulcitar	Gt PLUCK
109	G13	Cimbalon	Cp PERCUSSION
110	G14	EthncFlute	Rp PIPE
111	G15	Hichiriki	Rp SAX/REED
112	G16	Ryuteki	Rp PIPE
113	H01	Gagaku	Rp PIPE
114	H02	Kokyū	St SOLO
115	H03	Digidoo	Rp PIPE
116	H04	Bali	Dr PERCUSSION
117	H05	Indo	Gt PLUCK
118	H06	Trip East	Dr PERCUSSION
119	H07	Tabla	Dr PERCUSSION
120	H08	Djembe	Dr PERCUSSION
121	H09	Djerimbe	Cp PERCUSSION
122	H10	Udu	Dr PERCUSSION
123	H11	Tribal	Dr PERCUSSION
124	H12	Log&Drum	Cp PERCUSSION
125	H13	Afro	Dr PERCUSSION
126	H14	Japanesque	Co SEQ
127	H15	EthnoShock	Me HIT
128	H16	Ethnology	Dr PERCUSSION

**PRE3 (MSB 63, LSB 2)**

Number	Voice Name	Category	Sub Category
1	A01	Ap	A.PIANO
2	A02	Ap	A.PIANO
3	A03	Ap	A.PIANO
4	A04	Ap	A.PIANO
5	A05	Ap	E.GRAND
6	A06	Ap	OTHER
7	A07	Kb	E.PIANO
8	A08	Kb	E.PIANO
9	A09	Kb	E.PIANO
10	A10	Kb	E.PIANO
11	A11	Ap	A.PIANO
12	A12	Kb	OTHER
13	A13	Or	OTHER
14	A14	Or	OTHER
15	A15	Or	ELECTRIC
16	A16	Or	ELECTRIC
17	B01	Or	ELECTRIC
18	B02	Ba	E.BASS
19	B03	Ba	SYNTH
20	B04	Ba	SYNTH
21	B05	Ba	SYNTH
22	B06	Ba	SYNTH
23	B07	Ba	SYNTH
24	B08	Ba	SYNTH
25	B09	Ba	SYNTH
26	B10	Ba	SYNTH
27	B11	Ba	SYNTH
28	B12	Ba	SYNTH
29	B13	Ba	SYNTH
30	B14	Ba	SYNTH
31	B15	Ba	SYNTH
32	B16	Ba	SYNTH
33	C01	Ba	SYNTH
34	C02	Ba	SYNTH
35	C03	Ba	SYNTH
36	C04	St	SYNTH
37	C05	St	SYNTH
38	C06	St	SYNTH
39	C07	St	SYNTH
40	C08	Br	SYNTH
41	C09	Br	SYNTH
42	C10	Br	SYNTH
43	C11	Br	SYNTH
44	C12	Br	SYNTH
45	C13	Rp	OTHER
46	C14	Ld	HARD
47	C15	Ld	SOFT
48	C16	Ld	SOFT
49	D01	Ld	HARD
50	D02	Ld	SOFT
51	D03	Ld	HARD
52	D04	Ld	HARD
53	D05	Ld	HARD
54	D06	Ld	HARD
55	D07	Ld	HARD
56	D08	Ld	SOFT
57	D09	Ld	SOFT
58	D10	Ld	HARD
59	D11	Pd	BRIGHT
60	D12	Pd	BRIGHT
61	D13	Pd	SOFT
62	D14	Pd	BRIGHT
63	D15	Pd	BRIGHT
64	D16	Pd	SOFT

Number	Voice Name	Category	Sub Category
65	E01	Pd	SOFT
66	E02	Pd	SOFT
67	E03	Pd	BRIGHT
68	E04	Pd	BRIGHT
69	E05	Pd	SOFT
70	E06	Pd	BRIGHT
71	E07	Pd	BRIGHT
72	E08	Pd	SOFT
73	E09	Pd	SOFT
74	E10	Pd	SOFT
75	E11	Pd	SOFT
76	E12	Pd	BRIGHT
77	E13	Pd	BRIGHT
78	E14	Pd	BRIGHT
79	E15	Pd	SOFT
80	E16	Pd	CHOIR
81	F01	Pd	CHOIR
82	F02	Pd	CHOIR
83	F03	Sc	SOFT
84	F04	Sc	HARD
85	F05	Sc	HARD
86	F06	Me	MOTION
87	F07	Me	MOTION
88	F18	Me	MOTION
89	F09	Me	MOTION
90	F10	Me	MOTION
91	F11	Me	MOTION
92	F12	Me	MOTION
93	F13	Me	MOTION
94	F14	Me	MOTION
95	F15	Me	MOTION
96	F16	Me	MOTION
97	G01	Me	HIT
98	G02	Me	MOTION
99	G03	Me	MOTION
100	G04	Me	MOTION
101	G05	Me	MOTION
102	G06	Me	MOTION
103	G07	Me	MOTION
104	G08	Me	MOTION
105	G09	Co	SEQ
106	G10	Co	SEQ
107	G11	Co	SEQ
108	G12	Co	SEQ
109	G13	Co	SEQ
110	G14	Co	SEQ
111	G15	Co	SEQ
112	G16	Co	SEQ
113	H01	Co	SEQ
114	H02	Co	SEQ
115	H03	Co	SEQ
116	H04	Co	SEQ
117	H05	Se	SYNTH
118	H06	Se	SYNTH
119	H07	Se	SYNTH
120	H08	Se	SYNTH
121	H09	Se	SYNTH
122	H10	Se	SYNTH
123	H11	Se	SYNTH
124	H12	Se	NATURAL
125	H13	Se	SYNTH
126	H14	Se	NATURAL
127	H15	Se	NATURAL
128	H16	Se	SYNTH

**USER (MSB 63, LSB 8)**

Number	Voice Name	Category	Sub Category	
1	A01	BriteS700	Ap	A.PIANO
2	A02	Old Blues	Ap	A.PIANO
3	A03	S700&OldEp	Ap	OTHER
4	A04	S700&DX	Ap	OTHER
5	A05	Bell Piano	Ap	OTHER
6	A06	Dream	Ap	OTHER
7	A07	Tomorrow	Ap	OTHER
8	A08	Piano&Pad	Ap	OTHER
9	A09	CP80&EP	Kb	E.PIANO
10	A10	Yama EP's	Kb	OTHER
11	A11	Mr. Klank	Kb	E.PIANO
12	A12	Electro	Kb	E.PIANO
13	A13	Satellite	Kb	E.PIANO
14	A14	Partita	Or	PIPE
15	A15	Reed	Or	PIPE
16	A16	Org&Voice	Or	OTHER
17	B01	Stingfng	Ba	E.BASS
18	B02	Fat Low	Ba	SYNTH
19	B03	OB Saw	Ba	SYNTH
20	B04	Ana Decay	Ba	SYNTH
21	B05	MiniAnalog	Ba	SYNTH
22	B06	SimpleReso	Ba	SYNTH
23	B07	SyzStrng	St	SYNTH
24	B08	Real Harp	Gt	PLUCK
25	B09	Real Flute	Rp	PIPE
26	B10	Twilight	Pd	BRIGHT
27	B11	HighSine	Pd	SOFT
28	B12	Hi Q Pad	Pd	BRIGHT
29	B13	Snow Storm	Pd	BRIGHT
30	B14	Classic	Sc	HARD
31	B15	Step Down	Me	MOTION
32	B16	Ens+Flute	St	ENSEM.
33	C01	Polygroove	Co	SEQ
34	C02	ANbasicARP	Co	SEQ
35	C03	Pop Split	Co	SPLIT
36	C04	Pianosyn	Ap	OTHER
37	C05	Wake Up	Pd	BRIGHT
38	C06	BackPad MW	Pd	SOFT
39	C07	Poly Comp	Sc	HARD
40	C08	Surface	Me	MOTION
41	C09	HPF+LPFpad	Pd	BRIGHT
42	C10	Hip Chordz	Co	SEQ
43	C11	CrushPadMW	Me	MOTION
44	C12	Warmest	St	SYNTH
45	C13	Sadness	Pd	SOFT
46	C14	Bright Aah	Pd	CHOIR
47	C15	FatSwell	Pd	BRIGHT
48	C16	Pearls	Pd	BRIGHT
49	D01	Sonar Pad	Pd	SOFT
50	D02	Alaska	Me	MOTION
51	D03	Happy Boy	Co	SEQ
52	D04	Whisperer	Pd	BRIGHT
53	D05	Pad Bells	Cp	BELL
54	D06	Funky Mood	Co	SEQ
55	D07	For you!	Co	SEQ
56	D08	Gruvmaster	Co	SEQ
57	D09	PlucknGruv	Co	SEQ
58	D10	AllYouNeed	Me	MOTION
59	D11	Atlantis	Me	MOTION
60	D12	Pad&Syn	Pd	BRIGHT
61	D13	Warm AN	St	SYNTH
62	D14	BigOctave	St	SYNTH
63	D15	OldStrings	St	ENSEM.
64	D16	Pro Lead	Ld	HARD

Number	Voice Name	Category	Sub Category	
65	E01	Shine on	Pd	SOFT
66	E02	Pianospher	Ap	OTHER
67	E03	SuperStrgs	St	SYNTH
68	E04	Guitar&Pad	Gt	A.GTR
69	E05	PluckPno	Ap	OTHER
70	E06	Softstars	Pd	CHOIR
71	E07	Soft Tar	Me	MOTION
72	E08	Sorted	Co	SEQ
73	E09	Trendy Wah	Ba	SYNTH
74	E10	Feed S&H	Se	SYNTH
75	E11	Didge	Me	MOTION
76	E12	Old House	Ba	SYNTH
77	E13	HPF Dance	Ld	HARD
78	E14	Exodus	Ba	SYNTH
79	E15	S/H Gruv	Me	MOTION
80	E16	Dark Light	Pd	SOFT
81	F01	Boom Bass	Ba	SYNTH
82	F02	Shandala	Pd	CHOIR
83	F03	Titan	Co	SEQ
84	F04	Puls Step	Ba	SYNTH
85	F05	Big Lead	Ld	HARD
86	F06	Squeaky	Ld	HARD
87	F07	Auto Wah	Gt	E.GTR
88	F18	MetalPiano	Ap	OTHER
89	F09	BrokenStar	Pd	SOFT
90	F10	Smooth	Ba	SYNTH
91	F11	Fuzzline	Ba	SYNTH
92	F12	Brief	Ba	SYNTH
93	F13	Dist-MW	Ld	HARD
94	F14	Hit&Down	Me	HIT
95	F15	Sand	Me	MOTION
96	F16	R&B Steel	Gt	A.GTR
97	G01	LoSnake	Ba	SYNTH
98	G02	Additive	Ba	SYNTH
99	G03	Rap Lead 1	Ld	SOFT
100	G04	Orch Hits	Me	HIT
101	G05	Melo Trmlo	Gt	E.GTR
102	G06	DigiGrand2	Ap	E.GRAND
103	G07	CheapEP	Kb	E.PIANO
104	G08	AnaMarcato	St	SYNTH
105	G09	Evolve	Me	MOTION
106	G10	Wazzo	Ba	SYNTH
107	G11	Rap Lead 2	Ld	HARD
108	G12	Early Lead	Ld	SOFT
109	G13	BDSrtrch	Se	SYNTH
110	G14	Mayday MW	Ld	HARD
111	G15	CoolWAH	Gt	E.GTR
112	G16	HipWahEP	Kb	E.PIANO
113	H01	Rap Lead 3	Ld	HARD
114	H02	DarkBass	Ba	SYNTH
115	H03	HiPaWheel	Ld	HARD
116	H04	Pierced	Ld	HARD
117	H05	PortaBass	Ba	SYNTH
118	H06	Sine Lead	Ld	SOFT
119	H07	UK Oam	Ba	SYNTH
120	H08	Rap Toyz	Se	SYNTH
121	H09	Future Z	Ld	HARD
122	H10	Dead?Alive	Me	MOTION
123	H11	SlowSuckr	St	SYNTH
124	H12	Munchkins	Pd	CHOIR
125	H13	Snoop Bass	Ba	SYNTH
126	H14	BabeMagnet	Ld	SOFT
127	H15	Rabino	Co	SEQ
128	H16	Hip Voice	Ld	HARD

## GM (MSB 0, LSB 0)

Number	Voice Name	Category	Sub Category
1	A01	Ap	A.PIANO
2	A02	Ap	A.PIANO
3	A03	Ap	E.GRAND
4	A04	Ap	A.PIANO
5	A05	Kb	E.PIANO
6	A06	Kb	E.PIANO
7	A07	Kb	OTHER
8	A08	Kb	CLAVI
9	A09	Cp	MALLET
10	A10	Cp	MALLET
11	A11	Cp	PERCUSSION
12	A12	Cp	MALLET
13	A13	Cp	MALLET
14	A14	Cp	MALLET
15	A15	Cp	BELL
16	A16	Cp	PERCUSSION
17	B01	Or	ELECTRIC
18	B02	Or	ELECTRIC
19	B03	Or	ELECTRIC
20	B04	Or	PIPE
21	B05	Or	OTHER
22	B06	Kb	OTHER
23	B07	Rp	OTHER
24	B08	Kb	OTHER
25	B09	Gt	A.GUITAR
26	B10	Gt	A.GUITAR
27	B11	Gt	E.GUITAR
28	B12	Gt	E.GUITAR
29	B13	Gt	E.GUITAR
30	B14	Gt	E.GUITAR
31	B15	Gt	E.GUITAR
32	B16	Gt	E.GUITAR
33	C01	Ba	A.BASS
34	C02	Ba	E.BASS
35	C03	Ba	E.BASS
36	C04	Ba	E.BASS
37	C05	Ba	E.BASS
38	C06	Ba	E.BASS
39	C07	Ba	SYNTH
40	C08	Ba	SYNTH
41	C09	St	SOLO
42	C10	St	SOLO
43	C11	St	SOLO
44	C12	St	SOLO
45	C13	St	ENSEMBLE
46	C14	Gt	PLUCK
47	C15	Gt	PLUCK
48	C16	Cp	PERCUSSION
49	D01	St	ENSEMBLE
50	D02	St	ENSEMBLE
51	D03	St	SYNTH
52	D04	St	SYNTH
53	D05	Pd	CHOIR
54	D06	Pd	CHOIR
55	D07	Pd	CHOIR
56	D08	Me	HIT
57	D09	Br	SOLO
58	D10	Br	SOLO
59	D11	Br	SOLO
60	D12	Br	SOLO
61	D13	Br	SECTION
62	D14	Br	SECTION
63	D15	Br	SYNTH
64	D16	Br	SYNTH

Number	Voice Name	Category	Sub Category
65	E01	Rp	SAX/REED
66	E02	Rp	SAX/REED
67	E03	Rp	SAX/REED
68	E04	Rp	SAX/REED
69	E05	Rp	SAX/REED
70	E06	Rp	SAX/REED
71	E07	Rp	SAX/REED
72	E08	Rp	SAX/REED
73	E09	Rp	PIPE
74	E10	Rp	PIPE
75	E11	Rp	PIPE
76	E12	Rp	PIPE
77	E13	Rp	PIPE
78	E14	Rp	PIPE
79	E15	Rp	PIPE
80	E16	Rp	PIPE
81	F01	Ld	HARD
82	F02	Ld	HARD
83	F03	Ld	SOFT
84	F04	Ld	HARD
85	F05	Ld	HARD
86	F06	Ld	SOFT
87	F07	Ld	HARD
88	F18	Ld	HARD
89	F09	Pd	BRIGHT
90	F10	Pd	SOFT
91	F11	Pd	BRIGHT
92	F12	Pd	CHOIR
93	F13	Pd	SOFT
94	F14	Pd	BRIGHT
95	F15	Pd	BRIGHT
96	F16	Pd	BRIGHT
97	G01	Me	MOTION
98	G02	Pd	BRIGHT
99	G03	Cp	BELL
100	G04	Pd	SOFT
101	G05	Sc	HARD
102	G06	Me	MOTION
103	G07	Me	MOTION
104	G08	Pd	BRIGHT
105	G09	Gt	PLUCK
106	G10	Gt	PLUCK
107	G11	Gt	PLUCK
108	G12	Gt	PLUCK
109	G13	Cp	PERCUSSION
110	G14	Rp	SAX/REED
111	G15	St	SOLO
112	G16	Rp	SAX/REED
113	H01	Cp	BELL
114	H02	Dr	PERCUSSION
115	H03	Cp	PERCUSSION
116	H04	Dr	PERCUSSION
117	H05	Dr	PERCUSSION
118	H06	Dr	DRUMS
119	H07	Dr	DRUMS
120	H08	Se	SYNTH
121	H09	Se	NATURAL
122	H10	Se	NATURAL
123	H11	Se	NATURAL
124	H12	Se	NATURAL
125	H13	Se	NATURAL
126	H14	Se	NATURAL
127	H15	Se	NATURAL
128	H16	Se	NATURAL



# Drum Voice List

## Drum Voice Name List

### Bank Select MSB 63, LSB 32

PRE No.	Voice Name	
1	PoweredStd	
2	DryStandrd	
3	RockSt1	
4	RockSt2	
5	RockMono1	
6	Hip Hop1	
7	Hip Hop2	
8	HipStick1	
9	T9HipKit1	
10	R&B Kit1	
11	R&B Kit2	
12	AnalogT9	
13	AnalogT8	
14	Tekno Kit	
15	House Kit1	These drum kits have been specially programmed for different music styles, yet closely follow the standard instrument order of the GM kit.
16	House Kit2	
17	Big Kit	
18	Break Kit	
19	Drum'nBass	
20	Acid Kit	
21	Jungle Kit	
22	Electric	
23	Human Kit	
24	Hard Kit	
25	DistrtdKit	
26	AmbientKit	
27	Jazz Kit	
28	Hip Hop3	
29	Hip Hop4	
30	HipStick2	
31	Garage	
32	ALL-ROUND	These original drum kits, programmed for the S90, feature a special non-standard order for ease in playing.
33	Rock Multi	
34	Hip Multi	
35	Percussion	
36	Latin Perc	
37	Gtr/Bs Fx	
38	Wacko Kit	
39	Wood Bits	
40	Metal Bits	
41	Hands Kit	These original kits feature a variety of instruments and special sound effects, and are grouped according to their type.
42	Scratches	
43	AcstSnares	
44	StSnares	
45	AllKicks	
46	DanceKicks	
47	Snare & Fx	
48	EasySnares	

### Bank Select MSB 63, LSB 40

USER No.	Voice Name	
1	RockMono2	These drum kits have been specially programmed for different music styles, yet closely follow the standard instrument order of the GM kit.
2	RockMono3	
3	Hip Hop5	
4	Hip Hop6	
5	T9HipKit2	
6	HipStick3	
7	HipStick4	
8	R&B Kit3	

### Bank Select MSB 127, LSB 0

GM Drum No.	Voice Name
1	Stereo GM

# Drum Kit Assign List

## PRE 1 PoweredStd

Note	Wave No.	Wave Name
C 0	735	Clave
C#0	1057	SdBrMtSt
D 0	1063	SdBrSwrSt
D#0	1060	SdBrM2St
E 0	1066	SdBswrAtSt
F 0	1053	SnLvRolSt
F#0	734	Castanet
G 0	866	SdNm1St
G#0	732	Stick
A 0	794	BdFkSonSt
A#0	898	SdBsSt1-3
B 0	785	BdLoSt
C 1	788	BdHsonSt
C#1	1042	SdCIRmSt
D 1	913	SdNmSonSt1-4
D#1	752	ClapT9
E 1	963	SdLdwSt1-4
F 1	1227	TomFlSt
F#1	1152	HHClF1St
G 1	1224	TomLoSt
G#1	1155	HHHf2St
A 1	1224	TomLoSt
A#1	1158	HHOp2St
B 1	1221	TomMdSt
C 2	1221	TomMdSt
C#2	1253	CrashSt
D 2	1218	TomHiSt
D#2	1258	RideSt
E 2	1267	ChinaSt
F 2	1261	CupSt
F#2	714	TambrnSw
G 2	1271	SplashSt
G#2	746	Cowbell2
A 2	1305	CrashRL
A#2	737	Vibraslap
B 2	1306	RideRL
C 3	675	BongoHi1-2
C#3	679	BongoLo1-3
D 3	663	CongaTip
D#3	661	CongaOp
E 3	669	TumbaOp
F 3	683	TmbaleH1-3
F#3	687	TmbaleL1-3
G 3	724	AgogoHi
G#3	725	AgogoLo
A 3	698	Cabasa1-2
A#3	696	MaracasSlr
B 3	738	Whistle
C 4	738	Whistle
C#4	728	GuiroShort
D 4	727	GuiroLong
D#4	735	Clave
E 4	736	WoodBlock
F 4	736	WoodBlock
F#4	674	CuicaHi
G 4	673	CuicaLo
G#4	741	TriangleMt
A 4	740	TriangleOp
A#4	704	Shaker1-2
B 4	750	SleighBel
C 5	751	BellTree
C#5	940	SdBIL1-3
D 5	963	SdLdwSt1-4
D#5	956	SdBHR1-3
E 5	983	SdHipSt1-2
F 5	785	BdLoSt
F#5	1021	SdLdwHMono
G 5	834	BdR&B1
G#5	1024	SdHeavy
A 5	808	BdRoom1
A#5	1018	SdAmb
B 5	794	BdFkSonSt
C 6	809	BdRoom2

## PRE 2 DryStandrd

Note	Wave No.	Wave Name
C 0	735	Clave
C#0	1057	SdBrMtSt
D 0	1063	SdBrSwrSt
D#0	1060	SdBrM2St
E 0	1066	SdBswrAtSt
F 0	1053	SnLvRolSt
F#0	734	Castanet
G 0	866	SdNm1St
G#0	732	Stick
A 0	773	BdFkSt1-2
A#0	900	SdBsSt2-3
B 0	782	BdHiSt
C 1	764	BdNmSt1-2
C#1	1042	SdCIRmSt
D 1	860	SdNmSonSt1-4
D#1	752	ClapT9
E 1	899	SdBsSt1-2
F 1	1227	TomFlSt
F#1	1131	HHClFSt1-4
G 1	1224	TomLoSt
G#1	1146	HHPd1St
A 1	1224	TomLoSt
A#1	1149	HHOpSt
B 1	1221	TomMdSt
C 2	1221	TomMdSt
C#2	1253	CrashSt
D 2	1218	TomHiSt
D#2	1258	RideSt
E 2	1267	ChinaSt
F 2	1261	CupSt
F#2	714	TambrnSw
G 2	1271	SplashSt
G#2	746	Cowbell2
A 2	1305	CrashRL
A#2	737	Vibraslap
B 2	1306	RideRL
C 3	675	BongoHi1-2
C#3	679	BongoLo1-3
D 3	663	CongaTip
D#3	661	CongaOp
E 3	669	TumbaOp
F 3	683	TmbaleH1-3
F#3	687	TmbaleL1-3
G 3	724	AgogoHi
G#3	725	AgogoLo
A 3	698	Cabasa1-2
A#3	696	MaracasSlr
B 3	738	Whistle
C 4	738	Whistle
C#4	728	GuiroShort
D 4	727	GuiroLong
D#4	735	Clave
E 4	736	WoodBlock
F 4	736	WoodBlock
F#4	674	CuicaHi
G 4	673	CuicaLo
G#4	741	TriangleMt
A 4	740	TriangleOp
A#4	704	Shaker1-2
B 4	750	SleighBel
C 5	751	BellTree
C#5	940	SdBIL1-3
D 5	963	SdLdwSt1-4
D#5	956	SdBHR1-3
E 5	983	SdHipSt1-2
F 5	785	BdLoSt
F#5	1021	SdLdwHMono
G 5	834	BdR&B1
G#5	1024	SdHeavy
A 5	808	BdRoom1
A#5	1018	SdAmb
B 5	794	BdFkSonSt
C 6	809	BdRoom2

## PRE 3 RockSt1

Note	Wave No.	Wave Name
C 0	763	AnaClick
C#0	1057	SdBrMtSt
D 0	1063	SdBrSwrSt
D#0	1060	SdBrM2St
E 0	1066	SdBswrAtSt
F 0	1047	SdRkRolSt
F#0	734	Castanet
G 0	992	SdRkOp1St
G#0	732	Stick
A 0	764	BdNmSt1-2
A#0	998	SdRkRim1St
B 0	782	BdHiSt
C 1	797	BdRk1St
C#1	1026	SdRkStk1St
D 1	992	SdRkOp1St
D#1	742	HandClapSt
E 1	995	SdRkMte1St
F 1	1236	TomRkLoSt
F#1	1161	HHClRkStSw
G 1	1236	TomRkLoSt
G#1	1170	HHPdRkStSw
A 1	1233	TomRkMdSt
A#1	1179	HHOpRkStSw
B 1	1233	TomRkMdSt
C 2	1230	TomRkHiSt
C#2	1253	CrashSt
D 2	1230	TomRkHiSt
D#2	1258	RideSt
E 2	1267	ChinaSt
F 2	1261	CupSt
F#2	759	TambrnRX5
G 2	1271	SplashSt
G#2	745	Cowbel1
A 2	1253	CrashSt
A#2	737	Vibraslap
B 2	1258	RideSt
C 3	675	BongoHi1-2
C#3	679	BongoLo1-3
D 3	663	CongaTip
D#3	662	CongaSlp
E 3	661	CongaOp
F 3	683	TmbaleH1-3
F#3	687	TmbaleL1-3
G 3	724	AgogoHi
G#3	725	AgogoLo
A 3	698	Cabasa1-2
A#3	696	MaracasSlr
B 3	738	Whistle
C 4	738	Whistle
C#4	728	GuiroShort
D 4	727	GuiroLong
D#4	735	Clave
E 4	736	WoodBlock
F 4	736	WoodBlock
F#4	674	CuicaHi
G 4	673	CuicaLo
G#4	741	TriangleMt
A 4	740	TriangleOp
A#4	704	Shaker1-2
B 4	750	SleighBel
C 5	751	BellTree
C#5	1010	SdRkFlmSt
D 5	1001	SdRkOp2St
D#5	1007	SdRkRim2St
E 5	1004	SdRkMte2St
F 5	774	BdFk1St
F#5	1050	SdRkRolDSt
G 5	788	BdHsonSt
G#5	963	SdLdwSt1-4
A 5	794	BdFkSonSt
A#5	921	SdSon3St
B 5	777	BdFkR1-2
C 6	788	BdHsonSt

## PRE 4 RockSt2

Note	Wave No.	Wave Name
C 0	763	AnaClick
C#0	1057	SdBrMtSt
D 0	1063	SdBrSwrSt
D#0	1060	SdBrM2St
E 0	1066	SdBswrAtSt
F 0	1047	SdRkRolSt
F#0	734	Castanet
G 0	1001	SdRkOp2St
G#0	732	Stick
A 0	785	BdLoSt
A#0	1007	SdRkRim2St
B 0	766	BdNm2St
C 1	800	BdRk2St
C#1	1029	SdRkStk2St
D 1	1001	SdRkOp2St
D#1	742	HandClapSt
E 1	1004	SdRkMte2St
F 1	1236	TomRkLoSt
F#1	1173	HHClRk2St
G 1	1236	TomRkLoSt
G#1	1181	HHHfOpRkSt
A 1	1233	TomRkMdSt
A#1	1180	HHOpRkSt
B 1	1233	TomRkMdSt
C 2	1230	TomRkHiSt
C#2	1253	CrashSt
D 2	1230	TomRkHiSt
D#2	1258	RideSt
E 2	1267	ChinaSt
F 2	1261	CupSt
F#2	759	TambrnRX5
G 2	1271	SplashSt
G#2	745	Cowbel1
A 2	1253	CrashSt
A#2	737	Vibraslap
B 2	1258	RideSt
C 3	675	BongoHi1-2
C#3	679	BongoLo1-3
D 3	663	CongaTip
D#3	662	CongaSlp
E 3	661	CongaOp
F 3	683	TmbaleH1-3
F#3	687	TmbaleL1-3
G 3	724	AgogoHi
G#3	725	AgogoLo
A 3	698	Cabasa1-2
A#3	696	MaracasSlr
B 3	738	Whistle
C 4	738	Whistle
C#4	728	GuiroShort
D 4	727	GuiroLong
D#4	735	Clave
E 4	736	WoodBlock
F 4	736	WoodBlock
F#4	674	CuicaHi
G 4	673	CuicaLo
G#4	741	TriangleMt
A 4	740	TriangleOp
A#4	704	Shaker1-2
B 4	750	SleighBel
C 5	751	BellTree
C#5	1010	SdRkFlmSt
D 5	992	SdRkOp1St
D#5	998	SdRkRim1St
E 5	995	SdRkMte1St
F 5	797	BdRk2L
F#5	1050	SdRkRolDSt
G 5	775	BdFk2St
G#5	963	SdLdwSt1-4
A 5	782	BdHiSt
A#5	922	SdSon4St
B 5	791	BdLsonSt
C 6	797	BdRk1St

## PRE 5 RockMono1

Note	Wave No.	Wave Name
C 0	763	AnaClick
C#0	1058	SdBrMtL
D 0	1064	SdBrSwrL
D#0	1061	SdBrM2L
E 0	1067	SdBrSwrAtL
F 0	1054	SnLvRoL
F#0	734	Castanet
G 0	973	SdLdwL1-4
G#0	732	Stick
A 0	803	BdDry1
A#0	962	SdBh3R
B 0	772	BdNm2R
C 1	810	BdRoom3
C#1	1045	SdCIRim2
D 1	929	SdSon3L
D#1	743	HandClapL
E 1	932	SdSon4R
F 1	1228	TomFIL
F#1	1175	HHClRk2R
G 1	1225	TomLoL
G#1	1178	HHPd1RkR
A 1	1222	TomMdl
A#1	1185	HHOpRkR
B 1	1222	TomMdl
C 2	1220	TomHIR
C#2	1254	CrashL
D 2	1220	TomHIR
D#2	1264	RideMono
E 2	1267	ChinaSt
F 2	1266	CupMono2
F#2	714	TambrnSw
G 2	1273	SplashR
G#2	745	Cowbel1
A 2	1254	CrashL
A#2	737	Vibraslap
B 2	1264	RideMono
C 3	675	BongoHi1-2
C#3	679	BongoLo1-3
D 3	663	CongaTip
D#3	662	CongaSlp
E 3	661	CongaOp
F 3	683	TmbaleH1-3
F#3	687	TmbaleL1-3
G 3	724	AgogoHi
G#3	725	AgogoLo
A 3	698	Cabasa1-2
A#3	696	MaracasSlr
B 3	738	Whistle
C 4	738	Whistle
C#4	728	GuiroShort
D 4	727	GuiroLong
D#4	735	Clave
E 4	736	WoodBlock
F 4	736	WoodBlock
F#4	674	CuicaHi
G 4	673	CuicaLo
G#4	741	TriangleMt
A 4	740	TriangleOp
A#4	704	Shaker1-2
B 4	750	SleighBel
C 5	751	BellTree
C#5	1044	SdCIRmR
D 5	1024	SdHeavy
D#5	1000	SdRkRim1R
E 5	1021	SdLdwHMono
F 5	801	BdRk2L
F#5	987	SdHipR1-2
G 5	841	BdBreakHrd
G#5	982	SdLdw4R
A 5	783	BdHL
A#5	956	SdBhR1-3
B 5	780	BdFkHL
C 6	795	BdFkSonL



**PRE 6 Hip Hop1**

Note	Wave No.	Wave Name
C 0	1033	SdHpStk2
C#0	554	VoxHitRev
D 0	560	TurnTable
D#0	537	HitBrass
E 0	583	ScratchSdR
F 0	1055	SnLvRolR
F#0	762	ClaveT8
G 0	991	SdHip2R
G#0	1039	SdHpStk6R
A 0	836	BdHipDp
A#0	1121	SdDodgL
B 0	822	BdT8-3
C 1	821	BdT8-2
C#1	1033	SdHpStk2
D 1	1117	SdClpAna
D#1	744	HandClapR
E 1	1098	SdR&B2
F 1	1247	TomT8
F#1	1193	HHClT8-1
G 1	1247	TomT8
G#1	1194	HHOpT8-1
A 1	1247	TomT8
A#1	1194	HHOpT8-1
B 1	1247	TomT8
C 2	1247	TomT8
C#2	1257	Crash2
D 2	1247	TomT8
D#2	1260	RideR
E 2	1275	CrashT8
F 2	1277	RideT9
F#2	759	TambrnRX5
G 2	1273	SplashR
G#2	748	MamboBdy
A 2	1274	CrashT9
A#2	737	Vibraslap
B 2	1277	RideT9
C 3	675	BongoHi1-2
C#3	679	BongoLo1-3
D 3	663	CongaTip
D#3	662	CongaSlp
E 3	661	CongaOp
F 3	683	TmbaleH1-3
F#3	687	TmbaleL1-3
G 3	725	AgogoLo
G#3	724	AgogoHi
A 3	707	ShakerHip1
A#3	761	Marc8T8
B 3	738	Whistle
C 4	738	Whistle
C#4	728	GuroShort
D 4	727	GuroLong
D#4	762	ClaveT8
E 4	736	WoodBlock
F 4	736	WoodBlock
F#4	674	CuicaHi
G 4	673	CuicaLo
G#4	741	TriangleMt
A 4	740	TriangleOp
A#4	758	AnaShaker
B 4	750	SleighBel
C 5	751	BellTree
C#5	1041	SdHipStk8
D 5	1090	SdJngl3
D#5	744	HandClapR
E 5	1107	SdHipRm5
F 5	573	Scratch H
F#5	574	Scratch L
G 5	575	ScratchDwn
G#5	577	ScratchHir
A 5	580	ScratchBdF
A#5	590	ScratchCmb
B 5	585	ScratchVoR
C 6	839	BdBreak2

**PRE 7 Hip Hop2**

Note	Wave No.	Wave Name
C 0	822	BdT8-3
C#0	1081	SdT8Rim
D 0	1099	SdHip1
D#0	752	ClapT9
E 0	1124	SdSyn
F 0	1055	SnLvRolR
F#0	1035	SdHpStk4
G 0	368	DjembeEd
G#0	1037	SdHpStk6St
A 0	820	BdT8-1
A#0	1097	SdR&B1Rm
B 0	840	BdBreakHvy
C 1	836	BdHipDp
C#1	1079	SdT8-4
D 1	1101	SdHip3
D#1	742	HandClapSt
E 1	1129	SdLofi
F 1	1229	TomFIR
F#1	1211	HHClLoFi
G 1	1225	TomLoL
G#1	1200	HHClBreak
A 1	1225	TomLoL
A#1	1212	HHOpLoFi
B 1	1215	TomLoL
C 2	1219	TomHiL
C#2	1256	Crash
D 2	1219	TomHiL
D#2	1277	RideT9
E 2	1270	China
F 2	1265	CupMono
F#2	759	TambrnRX5
G 2	1256	Crash
G#2	756	CowBelRX11
A 2	1255	CrashR
A#2	755	CowBelT8
B 2	1277	RideT9
C 3	676	BongoHi1
C#3	679	BongoLo1-3
D 3	663	CongaTip
D#3	662	CongaSlp
E 3	661	CongaOp
F 3	524	RadioNz
F#3	524	RadioNz
G 3	725	AgogoLo
G#3	725	AgogoLo
A 3	699	Cabasa1
A#3	761	Marc8T8
B 3	557	FxGun2
C 4	558	FxGun1
C#4	587	ScratchSpn
D 4	586	ScratchStp
D#4	762	ClaveT8
E 4	562	DoorSqk
F 4	553	HiQ2
F#4	580	ScratchBdF
G 4	581	ScratchBdR
G#4	741	TriangleMt
A 4	740	TriangleOp
A#4	758	AnaShaker
B 4	715	TambrnHit
C 5	751	BellTree
C#5	1087	SdHuman2
D 5	1112	SdBkRim3
D#5	540	StabHard
E 5	1088	SdJngl1
F 5	797	BdRk1St
F#5	575	ScratchDwn
G 5	367	Wataiko
G#5	511	HH Hit
A 5	541	StabOrgan2
A#5	534	Sonar1
B 5	560	TurnTable
C 6	561	Police

**PRE 8 HipStick1**

Note	Wave No.	Wave Name
C 0	1106	SdHipRm4
C#0	552	HiQ1
D 0	560	TurnTable
D#0	536	HitOrch1
E 0	581	ScratchBdR
F 0	1055	SnLvRolR
F#0	763	AnaClick
G 0	1105	SdHipRm3
G#0	1085	SdAnCRrim
A 0	836	BdHipDp
A#0	1083	SdAnSmRim
B 0	822	BdT8-3
C 1	821	BdT8-2
C#1	1081	SdT8Rim
D 1	1032	SdHpStk1
D#1	744	HandClapR
E 1	1033	SdHpStk2
F 1	1247	TomT8
F#1	1193	HHClT8-1
G 1	1247	TomT8
G#1	1194	HHOpT8-1
A 1	1247	TomT8
A#1	1194	HHOpT8-1
B 1	1247	TomT8
C 2	1247	TomT8
C#2	1257	Crash2
D 2	1247	TomT8
D#2	1260	RideR
E 2	1275	CrashT8
F 2	1277	RideT9
F#2	759	TambrnRX5
G 2	1273	SplashR
G#2	748	MamboBdy
A 2	1274	CrashT9
A#2	737	Vibraslap
B 2	1277	RideT9
C 3	675	BongoHi1-2
C#3	679	BongoLo1-3
D 3	663	CongaTip
D#3	662	CongaSlp
E 3	661	CongaOp
F 3	683	TmbaleH1-3
F#3	687	TmbaleL1-3
G 3	724	AgogoHi
G#3	725	AgogoLo
A 3	707	ShakerHip1
A#3	696	MaracasSlr
B 3	738	Whistle
C 4	738	Whistle
C#4	728	GuroShort
D 4	727	GuroLong
D#4	735	Clave
E 4	736	WoodBlock
F 4	736	WoodBlock
F#4	674	CuicaHi
G 4	673	CuicaLo
G#4	741	TriangleMt
A 4	740	TriangleOp
A#4	740	Shaker1-2
B 4	750	SleighBel
C 5	751	BellTree
C#5	1082	SdAnSm
D 5	1046	SdCIRim3
D#5	763	AnaClick
E 5	1045	SdCIRim2
F 5	573	Scratch H
F#5	574	Scratch L
G 5	575	ScratchDwn
G#5	577	ScratchHir
A 5	580	ScratchBdF
A#5	590	ScratchCmb
B 5	585	ScratchVoR
C 6	830	BdJngl2

**PRE 9 T9HipKit1**

Note	Wave No.	Wave Name
C 0	762	ClaveT8
C#0	1073	SdT9-5
D 0	560	TurnTable
D#0	532	Quiek
E 0	592	ScratchCb3
F 0	1054	SnLvRolL
F#0	763	AnaClick
G 0	1074	SdT9Gate
G#0	1130	SdRimSE
A 0	815	BdT9-3
A#0	1071	SdT9-3
B 0	814	BdT9-2
C 1	813	BdT9-1
C#1	1075	SdT9Rim
D 1	1073	SdT9-5
D#1	752	ClapT9
E 1	1072	SdT9-4
F 1	1246	TomT9Lo
F#1	1191	HHClT9
G 1	1246	TomT9Lo
G#1	1192	HHOpT9
A 1	1246	TomT9Lo
A#1	1192	HHOpT9
B 1	1246	TomT9Lo
C 2	1245	TomT9Hi
C#2	1274	CrashT9
D 2	1245	TomT9Hi
D#2	1277	RideT9
E 2	1274	CrashT9
F 2	1277	RideT9
F#2	759	TambrnRX5
G 2	1274	CrashT9
G#2	757	CowBelAnCR
A 2	1274	CrashT9
A#2	737	Vibraslap
B 2	1277	RideT9
C 3	675	BongoHi1-2
C#3	679	BongoLo1-3
D 3	663	CongaTip
D#3	662	CongaSlp
E 3	661	CongaOp
F 3	683	TmbaleH1-3
F#3	687	TmbaleL1-3
G 3	724	AgogoHi
G#3	725	AgogoLo
A 3	698	Cabasa1-2
A#3	696	MaracasSlr
B 3	738	Whistle
C 4	738	Whistle
C#4	728	GuroShort
D 4	727	GuroLong
D#4	735	Clave
E 4	736	WoodBlock
F 4	736	WoodBlock
F#4	674	CuicaHi
G 4	673	CuicaLo
G#4	741	TriangleMt
A 4	740	TriangleOp
A#4	704	Shaker1-2
B 4	750	SleighBel
C 5	751	BellTree
C#5	1075	SdT9Rim
D 5	1074	SdT9Gate
D#5	742	HandClapSt
E 5	1073	SdT9-5
F 5	573	Scratch H
F#5	574	Scratch L
G 5	575	ScratchDwn
G#5	576	ScratchHif
A 5	577	ScratchHir
A#5	578	ScratchLoF
B 5	579	ScratchLoR
C 6	817	BdT9Hd1

**PRE 10 R&B Kit1**

Note	Wave No.	Wave Name
C 0	819	BdT9Hd3
C#0	1084	SdAnCR
D 0	1083	SdAnSmRim
D#0	1117	SdClpAna
E 0	1074	SdT9Gate
F 0	1056	SdRimMono
F#0	1126	SdTImber
G 0	1123	SdFMRim
G#0	1091	SdJnglFx
A 0	806	BdVar1
A#0	1103	SdHipRm1
B 0	821	BdT8-2
C 1	851	BdZapMid
C#1	1081	SdT8Rim
D 1	1104	SdHipRm2
D#1	742	HandClapSt
E 1	1084	SdAnCR
F 1	822	BdT8-3
F#1	1195	HHClT8-2
G 1	822	BdT8-3
G#1	1198	HHClAnCR
A 1	822	BdT8-3
A#1	1196	HHOpT8-2
B 1	822	BdT8-3
C 2	822	BdT8-3
C#2	1256	Crash
D 2	822	BdT8-3
D#2	1277	RideT9
E 2	1270	China
F 2	1265	CupMono
F#2	715	TambrnHit
G 2	1256	Crash
G#2	745	Cowbel1
A 2	1274	CrashT9
A#2	755	CowBelT8
B 2	1258	RideSt
C 3	676	BongoHi1
C#3	679	BongoLo1-3
D 3	663	CongaTip
D#3	662	CongaSlp
E 3	661	CongaOp
F 3	552	HiQ1
F#3	552	HiQ1
G 3	725	AgogoLo
G#3	725	AgogoLo
A 3	758	AnaShaker
A#3	696	MaracasSlr
B 3	545	VoxDrum
C 4	545	VoxDrum
C#4	552	HiQ1
D 4	553	HiQ2
D#4	762	ClaveT8
E 4	552	HiQ1
F 4	587	ScratchSpn
F#4	577	ScratchHir
G 4	576	ScratchHif
G#4	741	TriangleMt
A 4	740	TriangleOp
A#4	706	Shaker2
B 4	715	TambrnHit
C 5	751	BellTree
C#5	1112	SdBkRim3
D 5	520	Mother
D#5	502	VoxBell
E 5	1096	SdR&B1
F 5	512	VoxAlk
F#5	377	Udo Hi
G 5	507	TranCho
G#5	519	Swarm
A 5	805	BdPop
A#5	1097	SdR&B1Rm
B 5	835	BdR&B2
C 6	1256	Crash

**PRE 11 R&B Kit2**

Note	Wave No.	Wave Name
C 0	808	BdRoom1
C#0	763	AnaClick
D 0	614	PlayFxAba4
D#0	1035	SdHpStk4
E 0	667	QuintTip
F 0	594	PickNoise1
F#0	1075	SdT9Rim
G 0	860	SdNmSt1-4
G#0	1097	SdR&B1Rm
A 0	764	BdNmSt1-2
A#0	894	SdFk3R
B 0	822	BdT8-3
C 1	834	BdR&B1
C#1	1046	SdClrRim3
D 1	1014	SdPcRim
D#1	742	HandClapSt
E 1	1097	SdR&B1Rm
F 1	822	BdT8-3
F#1	1195	HHClT8-2
G 1	822	BdT8-3
G#1	1193	HHClT8-1
A 1	822	BdT8-3
A#1	1196	HHOpT8-2
B 1	822	BdT8-3
C 2	1247	TomT8
C#2	1253	CrashSt
D 2	1247	TomT8
D#2	1258	RideSt
E 2	1267	ChinaSt
F 2	1261	CupSt
F#2	714	TambrnSw
G 2	1256	Crash
G#2	745	Cowbel1
A 2	1274	CrashT9
A#2	755	CowBelT8
B 2	1258	RideSt
C 3	676	BongoHi1
C#3	679	BongoLo1-3
D 3	663	CongaTip
D#3	662	CongaSlp
E 3	661	CongaOp
F 3	552	HiQ1
F#3	552	HiQ1
G 3	725	AgogoLo
G#3	758	AnaShaker
A 3	758	AnaShaker
A#3	696	MaracasSlr
B 3	545	VoxDrum
C 4	545	VoxDrum
C#4	552	HiQ1
D 4	553	HiQ2
D#4	762	ClaveT8
E 4	552	HiQ1
F 4	587	ScratchSpn
F#4	577	ScratchHiR
G 4	576	ScratchHiF
G#4	741	TriangleMt
A 4	740	TriangleOp
A#4	706	Shaker2
B 4	715	TambrnHit
C 5	751	BellTree
C#5	1129	SdLofi
D 5	1029	SdRkStk2St
D#5	1013	SdPicol
E 5	1098	SdR&B2
F 5	835	BdR&B2
F#5	1122	SdFM
G 5	836	BdHipDp
G#5	1128	SdHammer
A 5	859	BdSlimy
A#5	511	HH Hit
B 5	822	BdT8-3
C 6	560	TurnTable

**PRE 12 AnalogT9**

Note	Wave No.	Wave Name
C 0	814	BdT9-2
C#0	1084	SdAnCR
D 0	1073	SdT9-5
D#0	753	ClapAnSm
E 0	1074	SdT9Gate
F 0	1047	SdRkRolSt
F#0	1071	SdT9-3
G 0	1072	SdT9-4
G#0	1074	SdT9Gate
A 0	816	BdT9-4
A#0	1073	SdT9-5
B 0	813	BdT9-1
C 1	815	BdT9-3
C#1	1075	SdT9Rim
D 1	1069	SdT9-1
D#1	752	ClapT9
E 1	1070	SdT9-2
F 1	1246	TomT9Lo
F#1	1191	HHClT9
G 1	1246	TomT9Lo
G#1	1192	HHOpT9
A 1	1246	TomT9Lo
A#1	1192	HHOpT9
B 1	1245	TomT9Hi
C 2	1245	TomT9Hi
C#2	1274	CrashT9
D 2	1245	TomT9Hi
D#2	1277	RideT9
E 2	1270	China
F 2	1265	CupMono
F#2	759	TambrnRX5
G 2	1256	Crash
G#2	745	Cowbel1
A 2	1257	Crash2
A#2	755	CowBelT8
B 2	1260	RideR
C 3	754	CongaT8
C#3	754	CongaT8
D 3	663	CongaTip
D#3	662	CongaSlp
E 3	661	CongaOp
F 3	683	TimbaleH1-3
F#3	687	TimbaleL1-3
G 3	763	AnaClick
G#3	754	CongaT8
A 3	698	Cabasa1-2
A#3	696	MaracasSlr
B 3	557	FxGun2
C 4	558	FxGun1
C#4	573	Scratch H
D 4	575	ScratchDwn
D#4	552	HiQ1
E 4	552	HiQ1
F 4	553	HiQ2
F#4	574	Scratch L
G 4	574	Scratch L
G#4	741	TriangleMt
A 4	740	TriangleOp
A#4	758	AnaShaker
B 4	750	SleighBel
C 5	751	BellTree
C#5	1013	SdPicol
D 5	1080	SdT8-5
D#5	1050	SdRkRolDSt
E 5	1060	SdBrm2St
F 5	828	BdBlpHd
F#5	1088	SdJngl1
G 5	852	BdSus
G#5	1092	SdD&B1
A 5	839	BdBk2
A#5	1118	SdDist
B 5	853	BdTekPower
C 6	847	BdDistRM

**PRE 13 AnalogT8**

Note	Wave No.	Wave Name
C 0	820	BdT8-1
C#0	1084	SdAnCR
D 0	1079	SdT8-4
D#0	1117	SdClpAna
E 0	1078	SdT8-3
F 0	1247	TomT8
F#0	1080	SdT8-5
G 0	822	BdT8-3
G#0	1079	SdT8-4
A 0	821	BdT8-2
A#0	1078	SdT8-3
B 0	436	T8KickBass
C 1	820	BdT8-1
C#1	1081	SdT8Rim
D 1	1077	SdT8-2
D#1	752	ClapT9
E 1	1076	SdT8-1
F 1	1247	TomT8
F#1	1195	HHClT8-2
G 1	1247	TomT8
G#1	1194	HHOpT8-1
A 1	1247	TomT8
A#1	1194	HHOpT8-1
B 1	1247	TomT8
C 2	1247	TomT8
C#2	1275	CrashT8
D 2	1247	TomT8
D#2	1277	RideT9
E 2	1270	China
F 2	1265	CupMono
F#2	759	TambrnRX5
G 2	1273	SplashR
G#2	755	CowBelT8
A 2	1257	Crash2
A#2	737	Vibraslap
B 2	1260	RideR
C 3	754	CongaT8
C#3	754	CongaT8
D 3	754	CongaT8
D#3	754	CongaT8
E 3	754	CongaT8
F 3	684	TimbaleH1
F#3	688	TimbaleLo1
G 3	547	Glass
G#3	547	Glass
A 3	698	Cabasa1-2
A#3	761	MarcT8
B 3	557	FxGun2
C 4	558	FxGun1
C#4	578	AnaShaker
D 4	758	AnaShaker
D#4	762	ClaveT8
E 4	552	HiQ1
F 4	553	HiQ2
F#4	574	Scratch L
G 4	574	Scratch L
G#4	741	TriangleMt
A 4	740	TriangleOp
A#4	758	AnaShaker
B 4	750	SleighBel
C 5	751	BellTree
C#5	1099	SdHip1
D 5	1100	SdHip2
D#5	1102	SdHipGate
E 5	1108	SdBk1
F 5	827	BdBlp
F#5	1113	SdFx1
G 5	849	BdFxmnr
G#5	1128	SdHammer
A 5	850	BdZapHrd
A#5	1121	SdDodgL
B 5	853	BdTekPower
C 6	859	BdSlimy

**PRE 14 Tekno Kit**

Note	Wave No.	Wave Name
C 0	859	BdSlimy
C#0	1075	SdT9Rim
D 0	1080	SdT8-5
D#0	752	ClapT9
E 0	1071	SdT9-3
F 0	1086	SdHuman1
F#0	1101	SdHip3
G 0	1072	SdT9-4
G#0	1100	SdHip2
A 0	858	BdThkSkn
A#0	1070	SdT9-2
B 0	845	BdDist4
C 1	851	BdZapMid
C#1	1081	SdT8Rim
D 1	1080	SdT8-5
D#1	752	ClapT9
E 1	1124	SdSyn
F 1	1247	TomT8
F#1	1211	HHClLoFi
G 1	1247	TomT8
G#1	1212	HHOpLoFi
A 1	1247	TomT8
A#1	1212	HHOpLoFi
B 1	1247	TomT8
C 2	1247	TomT8
C#2	1275	CrashT8
D 2	1247	TomT8
D#2	1277	RideT9
E 2	1256	Crash
F 2	1265	CupMono
F#2	760	TambrnAnCR
G 2	1254	CrashL
G#2	755	CowBelT8
A 2	1274	CrashT9
A#2	755	CowBelT8
B 2	1276	CrashSyn
C 3	754	CongaT8
C#3	754	CongaT8
D 3	754	CongaT8
D#3	754	CongaT8
E 3	754	CongaT8
F 3	683	TimbaleH1-3
F#3	687	TimbaleL1-3
G 3	547	Glass
G#3	547	Glass
A 3	699	Cabasa1
A#3	761	MarcT8
B 3	557	FxGun2
C 4	558	FxGun1
C#4	573	Scratch H
D 4	575	ScratchDwn
D#4	552	HiQ1
E 4	552	HiQ1
F 4	553	HiQ2
F#4	574	Scratch L
G 4	574	Scratch L
G#4	741	TriangleMt
A 4	740	TriangleOp
A#4	758	AnaShaker
B 4	750	SleighBel
C 5	751	BellTree
C#5	368	DjembeEd
D 5	367	Wataiko
D#5	540	StabHard
E 5	536	HitOrch1
F 5	541	StabOrgan2
F#5	575	ScratchDwn
G 5	797	BdRk1St
G#5	511	HH Hit
A 5	367	Wataiko
A#5	534	Sonar1
B 5	560	TurnTable
C 6	561	Police

**PRE 15 House Kit1**

Note	Wave No.	Wave Name
C 0	816	BdT9-4
C#0	1081	SdT8Rim
D 0	1080	SdT8-5
D#0	742	HandClapSt
E 0	1121	SdDodgL
F 0	1053	SnLvRolSt
F#0	1071	SdT9-3
G 0	1076	SdT8-1
G#0	1073	SdT9-5
A 0	813	BdT9-1
A#0	1074	SdT9Gate
B 0	814	BdT9-2
C 1	815	BdT9-3
C#1	1075	SdT9Rim
D 1	1069	SdT9-1
D#1	752	ClapT9
E 1	1070	SdT9-2
F 1	1246	TomT9Lo
F#1	1193	HHClT8-1
G 1	1246	TomT9Lo
G#1	1192	HHOpT9
A 1	1246	TomT9Lo
A#1	1192	HHOpT9
B 1	1245	TomT9Hi
C 2	1245	TomT9Hi
C#2	1274	CrashT9
D 2	1245	TomT9Hi
D#2	1277	RideT9
E 2	1256	Crash
F 2	1265	CupMono
F#2	715	TambrnHit
G 2	1256	Crash
G#2	745	Cowbel1
A 2	1253	CrashT9
A#2	755	CowBelT8
B 2	1258	RideSt
C 3	676	BongoHi1
C#3	679	BongoLo1-3
D 3	663	CongaTip
D#3	662	CongaSlp
E 3	661	CongaOp
F 3	684	TimbaleH1
F#3	684	TimbaleH1
G 3	725	AgogoLo
G#3	725	AgogoLo
A 3	699	Cabasa1
A#3	696	MaracasSlr
B 3	545	VoxDrum
C 4	545	VoxDrum
C#4	728	GuiroShort
D 4	727	GuiroLong
D#4	735	Clave
E 4	736	WoodBlock
F 4	736	WoodBlock
F#4	674	CuicaHi
G 4	673	CuicaLo
G#4	741	TriangleMt
A 4	740	TriangleOp
A#4	758	AnaShaker
B 4	750	SleighBel
C 5	751	BellTree
C#5	1112	SdBkR&B1
D 5	520	Mother
D#5	502	VoxBell
E 5	1096	SdR&B1
F 5	512	VoxAlk
F#5	377	Udo Hi
G 5	507	TranCho
G#5	519	Swarm
A 5	805	BdPop
A#5	1097	SdR&B1Rm
B 5	835	BdR&B2
C 6	1256	Crash

**PRE 16 House Kit2**

Note	Wave No.	Wave Name
C 0	814	BdT9-2
C#0	1081	SdT8Rim
D 0	618	PlayFxABa8
D#0	752	ClapT9
E 0	1070	SdT9-2
F 0	1074	SdTRGate
F#0	1087	SdHuman2
G 0	1113	SdFx1
G#0	1129	SdLofi
A 0	818	BdT9Hd2
A#0	1075	SdT9Rim
B 0	815	BdT9-3
C 1	817	BdT9Hd1
C#1	1075	SdT9Rim
D 1	1127	SdWood
D#1	549	NzBurst
E 1	551	Zap2
F 1	1124	SdSyn
F#1	1191	HHClT9
G 1	1124	SdSyn
G#1	1192	HHOpT9
A 1	1124	SdSyn
A#1	1192	HHOpT9
B 1	1124	SdSyn
C 2	1124	SdSyn
C#2	1274	CrashT9
D 2	1124	SdSyn
D#2	1277	RideT9
E 2	1276	CrashSyn
F 2	1265	CupMono
F#2	715	TambrnHit
G 2	1275	CrashT8
G#2	745	Cowbel1
A 2	1256	Crash
A#2	755	CowBelT8
B 2	1258	RideSt
C 3	676	BongoHi1
C#3	679	BongoLo1-3
D 3	664	CongaHeel
D#3	662	CongaSlp
E 3	661	CongaOp
F 3	1248	TomSyn1
F#3	1248	TomSyn1
G 3	763	AnaClick
G#3	1130	SdRimSE
A 3	699	Cabasa1
A#3	696	MaracasSlr
B 3	545	VoxDrum
C 4	545	VoxDrum
C#4	760	TambrnAnCR
D 4	758	AnaShaker
D#4	762	ClaveT8
E 4	759	TambrnRX5
F 4	756	CowBelRX11
F#4	758	AnaShaker
G 4	576	ScratchHif
G#4	741	TriangleMt
A 4	740	TriangleOp
A#4	758	AnaShaker
B 4	750	SleighBel
C 5	751	BellTree
C#5	372	TabraBya
D 5	373	TabraNah
D#5	374	TablaMut
E 5	504	VoxBell
F 5	805	BdPop
F#5	377	Udo Hi
G 5	812	BdFXGate
G#5	520	Mother
A 5	813	BdT9-1
A#5	1112	SdBreakRol
B 5	1256	Crash
C 6	560	TurnTable

**PRE 17 Big Kit**

Note	Wave No.	Wave Name
C 0	812	BdFXGate
C#0	681	BongoLo2
D 0	1025	SdGM
D#0	742	HandClapSt
E 0	1020	SdGate2
F 0	1047	SdRkRolSt
F#0	998	SdRkRim1St
G 0	1013	SdPicol
G#0	1010	SdRkFlmSt
A 0	809	BdRoom2
A#0	1026	SdRkStk1St
B 0	810	BdRoom3
C 1	811	BdGate
C#1	1017	SdMdRim
D 1	1019	SdGate1
D#1	753	ClapAnSm
E 1	1018	SdAmb
F 1	1244	TomAmbLo
F#1	1202	HHClD&B
G 1	1244	TomAmbLo
G#1	1203	HHPdID&B
A 1	1244	TomAmbLo
A#1	1204	HHOpD&B
B 1	1243	TomAmbHi
C 2	1243	TomAmbHi
C#2	1253	CrashSt
D 2	1243	TomAmbHi
D#2	1258	RideSt
E 2	1267	ChinaSt
F 2	1265	CupMono
F#2	715	TambrnHit
G 2	1256	Crash
G#2	745	Cowbel1
A 2	1253	CrashSt
A#2	737	Vibraslap
B 2	1258	RideSt
C 3	676	BongoHi1
C#3	679	BongoLo1-3
D 3	663	CongaTip
D#3	662	CongaSlp
E 3	661	CongaOp
F 3	848	Bd+HH
F#3	848	Bd+HH
G 3	725	AgogoLo
G#3	725	AgogoLo
A 3	699	Cabasa1
A#3	696	MaracasSlr
B 3	557	FxGun2
C 4	558	FxGun1
C#4	573	Scratch H
D 4	575	ScratchDwn
D#4	735	Clave
E 4	736	WoodBlock
F 4	736	WoodBlock
F#4	574	Scratch L
G 4	574	Scratch L
G#4	741	TriangleMt
A 4	740	TriangleOp
A#4	706	Shaker2
B 4	750	SleighBel
C 5	751	BellTree
C#5	1118	SdDist
D 5	1122	SdFM
D#5	1123	SdFMRim
E 5	1125	SdClappy
F 5	810	BdRoom3
F#5	1126	SdTimber
G 5	797	BdRk1St
G#5	1130	SdRimSE
A 5	800	BdRk2St
A#5	1112	SdBreakRol
B 5	832	BdD&B1
C 6	809	BdRoom2

**PRE 18 Break Kit**

Note	Wave No.	Wave Name
C 0	837	BdBrkDp
C#0	984	SdHip1St
D 0	1129	SdLofi
D#0	1125	SdClappy
E 0	1021	SdLdwHMMono
F 0	1050	SdRkRolDSt
F#0	1019	SdGate1
G 0	1016	SdMid
G#0	1022	SdBrRim
A 0	840	BdBreakHvy
A#0	1106	SdHipRm4
B 0	839	BdBreak2
C 1	838	BdBreak1
C#1	1103	SdHipRm1
D 1	1110	SdBreak3
D#1	1108	SdBreak1
E 1	1109	SdBreak2
F 1	1224	TomLoSt
F#1	1167	HHClRkSR
G 1	1224	TomLoSt
G#1	1178	HHPdIRkR
A 1	1224	TomLoSt
A#1	1187	HHHfOpRkR
B 1	1218	TomHiSt
C 2	1218	TomHiSt
C#2	1254	CrashL
D 2	1218	TomHiSt
D#2	1259	RideL
E 2	1268	ChinaL
F 2	1265	CupMono
F#2	715	TambrnHit
G 2	1256	Crash
G#2	745	Cowbel1
A 2	1255	CrashR
A#2	756	CowBelRX11
B 2	1264	RideMono
C 3	676	BongoHi1
C#3	679	BongoLo1-3
D 3	663	CongaTip
D#3	662	CongaSlp
E 3	661	CongaOp
F 3	675	BongoHi1-2
F#3	679	BongoLo1-3
G 3	661	CongaOp
G#3	725	AgogoLo
A 3	699	Cabasa1
A#3	696	MaracasSlr
B 3	557	TimbaleHi1
C 4	688	TimbaleLo1
C#4	573	Scratch H
D 4	575	ScratchDwn
D#4	735	Clave
E 4	736	WoodBlock
F 4	736	WoodBlock
F#4	574	Scratch L
G 4	574	Scratch L
G#4	741	TriangleMt
A 4	740	TriangleOp
A#4	706	Shaker2
B 4	750	SleighBel
C 5	560	TurnTable
C#5	1112	SdBreakRol
D 5	520	Mother
D#5	528	Mind Bell
E 5	513	SdFx1
F 5	800	BdRk2St
F#5	533	LfoSeq
G 5	846	Ripper
G#5	549	NzBurst
A 5	561	Police
A#5	526	Fairwave
B 5	519	Swarm
C 6	524	RadioNz

**PRE 19 Drum'nBass**

Note	Wave No.	Wave Name
C 0	836	BdHipDp
C#0	681	BongoLo2
D 0	1098	SdR&B2
D#0	1126	SdTimber
E 0	1094	SdD&B3
F 0	1128	SdHammer
F#0	547	Glass
G 0	833	BdD&B2
G#0	1146	HHPdISt
A 0	836	BdHipDp
A#0	1158	HHOp2St
B 0	832	BdD&B1
C 1	833	BdD&B2
C#1	1017	SdMdRim
D 1	1092	SdD&B1
D#1	549	NzBurst
E 1	1093	SdD&B2
F 1	1244	TomAmbLo
F#1	1202	HHClD&B
G 1	1244	TomAmbLo
G#1	1203	HHPdID&B
A 1	1244	TomAmbLo
A#1	1204	HHOpD&B
B 1	1243	TomAmbHi
C 2	1243	TomAmbHi
C#2	1254	CrashL
D 2	1243	TomAmbHi
D#2	1258	RideSt
E 2	1270	China
F 2	1265	CupMono
F#2	715	TambrnHit
G 2	1256	Crash
G#2	745	Cowbel1
A 2	1253	CrashL
A#2	737	Vibraslap
B 2	1258	RideSt
C 3	676	BongoHi1
C#3	679	BongoLo1-3
D 3	663	CongaTip
D#3	662	CongaSlp
E 3	661	CongaOp
F 3	1095	SdD&B4
F#3	1205	HHfRVD&B
G 3	725	AgogoLo
G#3	725	AgogoLo
A 3	699	Cabasa1
A#3	696	MaracasSlr
B 3	557	FxGun2
C 4	558	FxGun1
C#4	728	GuiroShort
D 4	727	GuiroLong
D#4	735	Clave
E 4	495	Sine
F 4	495	Sine
F#4	462	P50-1
G 4	653	PlyFxsH17S
G#4	560	TurnTable
A 4	740	TriangleOp
A#4	750	Shaker2
B 4	750	SleighBel
C 5	751	BellTree
C#5	1118	SdDist
D 5	1122	SdFM
D#5	1123	SdFMRim
E 5	1125	SdClappy
F 5	832	BdD&B1
F#5	1126	SdTimber
G 5	846	BdDist5
G#5	1130	SdRimSE
A 5	845	BdDist4
A#5	1101	SdHip3
B 5	859	BdSlimy
C 6	848	Bd+HH

**PRE 20 Acid Kit**

Note	Wave No.	Wave Name
C 0	855	BdATite
C#0	1081	SdT8Rim
D 0	1090	SdJngl3
D#0	742	HandClapSt
E 0	1076	SdT8-1
F 0	1053	SnLvRolSt
F#0	955	SdBhL1-3
G 0	962	SdBh3R
G#0	914	SdSonSt1-3
A 0	773	BdFkSt1-2
A#0	898	SdBsSt1-3
B 0	770	BdNm1R
C 1	780	BdFkHL
C#1	1031	SdRkStk2R
D 1	974	SdLwR1-4
D#1	752	ClapT9
E 1	973	SdLwL1-4
F 1	1246	TomT9Lo
F#1	1167	HHClRkSR
G 1	1246	TomT9Lo
G#1	1175	HHClRk2R
A 1	1246	TomT9Lo
A#1	1187	HHHfOpRkR
B 1	1245	TomT9Hi
C 2	1245	TomT9Hi
C#2	1254	CrashL
D 2	1245	TomT9Hi
D#2	1260	RideR
E 2	1256	Crash
F 2	1262	CupL
F#2	715	TambrnHit
G 2	1256	Crash
G#2	745	Cowbel1
A 2	1254	CrashL
A#2	755	CowBelT8
B 2	1264	RideMono
C 3	675	BongoHi1-2
C#3	679	BongoLo1-3
D 3	663	CongaTip
D#3	662	CongaSlp
E 3	661	CongaOp
F 3	684	TimbaleHi1
F#3	684	TimbaleHi1
G 3	724	AgogoHi
G#3	725	AgogoLo
A 3	699	Cabasa1
A#3	696	MaracasSlr
B 3	557	FxGun2
C 4	558	FxGun1
C#4	573	Scratch H
D 4	575	ScratchDwn
D#4	552	HiQ1
E 4	552	HiQ1
F 4	553	HiQ2
F#4	574	Scratch L
G 4	574	Scratch L
G#4	741	TriangleMt
A 4	740	TriangleOp
A#4	758	AnaShaker
B 4	750	SleighBel
C 5	751	BellTree
C#5	1073	SdT9-5
D 5	1073	SdT9-5
D#5	1073	SdT9-5
E 5	1073	SdT9-5
F 5	773	BdFkSt1-2
F#5	1092	SdD&B1
G 5	788	BdHsonSt
G#5	1102	SdHipGate
A 5	812	BdFXGate
A#5	1108	SdBreak1
B 5	829	BdJngl1
C 6	840	BdBreakHvy

**PRE 21 Jungle Kit**

Note	Wave No.	Wave Name
C 0	830	BdJngl2
C#0	1017	SdMdRim
D 0	1090	SdJngl3
D#0	1090	SdJngl3
E 0	1014	SdPcRim
F 0	1056	SdRollMono
F#0	1127	SdWood
G 0	1098	SdR&B2
G#0	1093	SdD&B2
A 0	830	BdJngl2
A#0	1091	SdJnglFx
B 0	831	BdJngl3
C 1	829	BdJngl1
C#1	1106	SdHipRm4
D 1	1089	SdJngl2
D#1	1091	SdJnglFx
E 1	1088	SdJngl1
F 1	1228	TomFIL
F#1	1165	HHClRkRSw
G 1	1225	TomLoL
G#1	1172	HHPdIRkRSw
A 1	1223	TomMdR
A#1	1183	HHOpRkRSw
B 1	1223	TomMdR
C 2	1220	TomHiR
C#2	1254	CrashL
D 2	1220	TomHiR
D#2	1260	RideR
E 2	1270	China
F 2	1265	CupMono
F#2	715	TambrnHit
G 2	1256	Crash
G#2	745	CowBel1
A 2	1253	CrashSt
A#2	737	Vibraslap
B 2	1258	RideSt
C 3	676	BongoHi1
C#3	679	BongoLo1-3
D 3	663	CongaTip
D#3	662	CongaSlp
E 3	661	CongaOp
F 3	373	TabraNah
F#3	372	TabraBya
G 3	725	AgogoLo
G#3	725	AgogoLo
A 3	699	Cabasa1
A#3	696	MaracasSlr
B 3	684	TimbaleHi1
C 4	688	TimbaleLo1
C#4	728	GuiroShort
D 4	727	GuiroLong
D#4	735	Clave
E 4	736	WoodBlock
F 4	736	WoodBlock
F#4	674	CuicaHi
G 4	673	CuicaLo
G#4	741	TriangleMt
A 4	740	TriangleOp
A#4	706	Shaker2
B 4	750	SleighBel
C 5	751	BellTree
C#5	1205	HHRvD&B
D 5	572	RainLoop
D#5	573	Scratch H
E 5	574	Scratch L
F 5	828	BdBlpHd
F#5	1124	SdSyn
G 5	548	IndusTom
G#5	717	PandieroOp
A 5	546	Ripper
A#5	567	TelRing
B 5	579	ScratchLoR
C 6	556	TapeRewnd

**PRE 22 Electric**

Note	Wave No.	Wave Name
C 0	824	BdAnCR
C#0	827	BdBlip
D 0	1080	SdT8-5
D#0	753	ClapAnSm
E 0	1104	SdHipRm2
F 0	1056	SdRollMono
F#0	1076	SdT8-1
G 0	1084	SdAnCR
G#0	1077	SdT8-2
A 0	820	BdT8-1
A#0	1079	SdT8-4
B 0	827	BdBlip
C 1	821	BdT8-2
C#1	1081	SdT8Rim
D 1	1078	SdT8-3
D#1	752	ClapT9
E 1	753	ClapAnSm
F 1	1249	TomSyn2
F#1	1195	HHClT8-2
G 1	1249	TomSyn2
G#1	1194	HHOpT8-1
A 1	1249	TomSyn2
A#1	1196	HHOpT8-2
B 1	1249	TomSyn2
C 2	1249	TomSyn2
C#2	1274	CrashT9
D 2	1249	TomSyn2
D#2	1277	RideT9
E 2	1256	Crash
F 2	1276	CrashSyn
F#2	1275	CrashT8
G 2	1256	Crash
G#2	1130	SdRimSE
A 2	1253	CrashSt
A#2	755	CowBelT8
B 2	1276	CrashSyn
C 3	1247	TomT8
C#3	1247	TomT8
D 3	1247	TomT8
D#3	1247	TomT8
E 3	1247	TomT8
F 3	571	Applause
F#3	566	Telephone
G 3	563	Heartbeat
G#3	555	Bomb
A 3	1212	HHOpLoFi
A#3	696	MaracasSlr
B 3	551	Zap2
C 4	550	Zap1
C#4	573	Scratch H
D 4	575	ScratchDwn
D#4	552	HiQ1
E 4	552	HiQ1
F 4	553	HiQ2
F#4	574	Scratch L
G 4	544	HitOrch2
G#4	1215	HHClFx
A 4	1216	HHOpFx
A#4	758	AnaShaker
B 4	758	AnaShaker
C 5	560	TurnTable
C#5	1112	SdBkRim1R
D 5	520	Mother
D#5	528	Mind Bell
E 5	1113	SdFx1
F 5	800	BdRk2St
F#5	533	LfoSeq
G 5	546	Ripper
G#5	549	NzBurst
A 5	561	Police
A#5	526	Fairwave
B 5	519	Swarm
C 6	524	RadioNz

**PRE 23 Human Kit**

Note	Wave No.	Wave Name
C 0	825	BdHuman1
C#0	584	ScratchVoF
D 0	543	Hit Uhh
D#0	585	ScratchVoR
E 0	1091	SdJnglFx
F 0	1047	SdRkRolSt
F#0	1108	SdBkR1St
G 0	1084	SdAnCR
G#0	1069	SdT9-1
A 0	852	BdSus
A#0	1032	SdHpStk1
B 0	825	BdHuman1
C 1	826	BdHuman2
C#1	1127	SdWood
D 1	1086	SdHuman1
D#1	1120	SdDodgH
E 1	1087	SdHuman2
F 1	825	BdHuman1
F#1	1217	HHOpHuman
G 1	825	BdHuman1
G#1	1217	HHOpHuman
A 1	825	BdHuman1
A#1	1217	HHOpHuman
B 1	825	BdHuman1
C 2	825	BdHuman1
C#2	549	NzBurst
D 2	825	BdHuman1
D#2	1275	CrashT8
E 2	1270	China
F 2	1265	CupMono
F#2	583	ScratchSdR
G 2	1271	SplashSt
G#2	545	VoxDrum
A 2	1257	Crash2
A#2	755	CowBelT8
B 2	542	StabAah
C 3	676	BongoHi1
C#3	679	BongoLo1-3
D 3	663	CongaTip
D#3	662	CongaSlp
E 3	661	CongaOp
F 3	683	TmbaleH1-3
F#3	687	TmbaleL1-3
G 3	725	AgogoLo
G#3	725	AgogoLo
A 3	699	Cabasa1
A#3	696	MaracasSlr
B 3	557	FxGun2
C 4	558	FxGun1
C#4	573	Scratch H
D 4	575	ScratchDwn
D#4	578	ScratchLoF
E 4	579	ScratchLoR
F 4	553	HiQ2
F#4	574	Scratch L
G 4	574	Scratch L
G#4	741	TriangleMt
A 4	740	TriangleOp
A#4	756	Shaker2
B 4	750	SleighBel
C 5	560	TurnTable
C#5	1000	SdRkRim1R
D 5	564	Helicopter
D#5	540	StabHard
E 5	1019	SdGate1
F 5	797	BdRk1St
F#5	575	ScratchDwn
G 5	823	BdAnSm
G#5	534	Sonar1
A 5	367	Wataiko
A#5	367	Wataiko
B 5	511	HH Hit
C 6	541	StabOrgan2

**PRE 24 Hard Kit**

Note	Wave No.	Wave Name
C 0	844	BdDist3
C#0	1127	SdWood
D 0	1019	SdGate1
D#0	742	HandClapSt
E 0	1020	SdGate2
F 0	1056	SdRollMono
F#0	1117	SdCipAna
G 0	1101	SdHip3
G#0	546	Ripper
A 0	847	BdDistRM
A#0	1081	SdT8Rim
B 0	843	BdDist2
C 1	842	BdDist1
C#1	1017	SdMdRim
D 1	1118	SdDist
D#1	549	NzBurst
E 1	1114	SdFx2
F 1	1252	TomDistLo
F#1	1191	HHClT9
G 1	1252	TomDistLo
G#1	1192	HHOpT9
A 1	1252	TomDistLo
A#1	1192	HHOpT9
B 1	1251	TomDistHi
C 2	1251	TomDistHi
C#2	1274	CrashT9
D 2	1251	TomDistHi
D#2	1277	RideT9
E 2	1270	China
F 2	1265	CupMono
F#2	760	TambrnAnCR
G 2	1256	Crash
G#2	755	CowBelT8
A 2	1253	CrashSt
A#2	737	Vibraslap
B 2	1258	RideSt
C 3	1126	SdTimber
C#3	1126	SdTimber
D 3	663	CongaTip
D#3	662	CongaSlp
E 3	661	CongaOp
F 3	848	Bd+HH
F#3	848	Bd+HH
G 3	547	Glass
G#3	547	Glass
A 3	699	Cabasa1
A#3	696	MaracasSlr
B 3	557	FxGun2
C 4	558	FxGun1
C#4	573	Scratch H
D 4	575	ScratchDwn
D#4	552	HiQ1
E 4	552	HiQ1
F 4	553	HiQ2
F#4	574	Scratch L
G 4	574	Scratch L
G#4	741	TriangleMt
A 4	740	TriangleOp
A#4	758	AnaShaker
B 4	750	SleighBel
C 5	751	BellTree
C#5	1118	SdDist
D 5	1122	SdFM
D#5	1123	SdFMRim
E 5	1125	SdClappy
F 5	849	BdFxHmr
F#5	548	IndusTom
G 5	832	BdD&B1
G#5	548	IndusTom
A 5	810	BdRoom3
A#5	548	IndusTom
B 5	816	BdT9-4
C 6	1128	SdHammer

**PRE 25 DistrtdKit**

Note	Wave No.	Wave Name
C 0	763	AnaClick
C#0	1057	SdBrsMtSt
D 0	1063	SdBrsWrSt
D#0	1060	SdBrsMt2St
E 0	1066	SdBrsWrAtSt
F 0	1053	SnLvRolSt
F#0	734	Castanet
G 0	866	SdNm1St
G#0	732	Stick
A 0	802	BdRk2R
A#0	969	SdLw1St
B 0	838	HdBkRk1
C 1	802	BdRk2R
C#1	1031	SdRkStk2R
D 1	925	SdSon1L
D#1	743	HandClapL
E 1	1014	SdPcRim
F 1	1244	TomAmbLo
F#1	1175	HHClRk2R
G 1	1244	TomAmbLo
G#1	1178	HHPdIRkR
A 1	1244	TomAmbLo
A#1	1185	HHOpRkR
B 1	1243	TomAmbHi
C 2	1243	TomAmbHi
C#2	1254	CrashL
D 2	1243	TomAmbHi
D#2	1260	RideR
E 2	1268	ChinaL
F 2	1263	CupR
F#2	714	TambrnSw
G 2	1273	SplashR
G#2	747	MamboBel
A 2	1254	CrashL
A#2	737	Vibraslap
B 2	1258	RideSt
C 3	675	BongoHi1-2
C#3	679	BongoLo1-3
D 3	663	CongaTip
D#3	662	CongaSlp
E 3	661	CongaOp
F 3	683	TmbaleH1-3
F#3	687	TmbaleL1-3
G 3	724	AgogoHi
G#3	725	AgogoLo
A 3	698	Cabasa1-2
A#3	696	MaracasSlr
B 3	738	Whistle
C 4	738	Whistle
C#4	728	GuiroShort
D 4	727	GuiroLong
D#4	735	Clave
E 4	736	WoodBlock
F 4	736	WoodBlock
F#4	591	ScratchCb2
G 4	577	ScratchHiR
G#4	741	TriangleMt
A 4	740	TriangleOp
A#4	704	Shaker1-2
B 4	750	SleighBel
C 5	751	BellTree
C#5	1013	SdPicol
D 5	1024	SdHeavy
D#5	1117	SdCipAna
E 5	1014	SdPcRim
F 5	809	BdRoom2
F#5	1016	SdMid
G 5	810	BdRoom3
G#5	1017	SdMdRim
A 5	811	BdGate
A#5	1019	SdGate1
B 5	812	BdFXGate
C 6	832	BdD&B1

**PRE 26 AmbientKit**

Note	Wave No.	Wave Name
C 0	827	BdBlip
C#0	553	HiQ2
D 0	1015	SdPcRim2
D#0	552	HiQ1
E 0	1084	SdAnCR
F 0	1248	TomSyn1
F#0	1213	HHClSyn
G 0	1248	TomSyn1
G#0	1215	HHClFX
A 0	1249	TomSyn2
A#0	1214	HHOpSyn
B 0	824	BdAnCR
C 1	813	BdT9-1
C#1	1034	SdHpStk3
D 1	1088	SdJngl1
D#1	752	ClapT9
E 1	1088	SdJngl1
F 1	1247	TomT8
F#1	1195	HHClT8-2
G 1	1247	TomT8
G#1	1194	HHOpT8-1
A 1	1247	TomT8
A#1	1196	HHOpT8-2
B 1	1247	TomT8
C 2	1247	TomT8
C#2	1276	CrashSyn
D 2	1247	TomT8
D#2	1277	RideT9
E 2	1256	Crash
F 2	1265	CupMono
F#2	715	TambrnHit
G 2	1256	Crash
G#2	755	CowBelT8
A 2	1253	CrashSt
A#2	737	Vibraslap
B 2	1258	RideSt
C 3	676	BongoHi1
C#3	679	BongoLo1-3
D 3	663	CongaTip
D#3	662	CongaSlp
E 3	661	CongaOp
F 3	683	TmbaleH1-3
F#3	687	TmbaleL1-3
G 3	547	Glass
G#3	547	Glass
A 3	699	Cabasa1
A#3	761	MarcasT8
B 3	568	Bird
C 4	569	Stream
C#4	559	Thunder
D 4	570	Gunshot
D#4	762	ClaveT8
E 4	736	WoodBlock
F 4	736	WoodBlock
F#4	760	TambrnAnCR
G 4	757	CowBelAnCR
G#4	741	TriangleMt
A 4	740	TriangleOp
A#4	758	AnaShaker
B 4	750	SleighBel
C 5	751	BellTree
C#5	1080	SdT8-5
D 5	534	Sonar1
D#5	1080	SdT8-5
E 5	523	Resonator
F 5	518	Bubble
F#5	1080	SdT8-5
G 5	518	Bubble
G#5	1080	SdT8-5
A 5	509	Eery
A#5	1080	SdT8-5
B 5	504	WindChime
C 6	504	WindChime

**PRE 27 Jazz Kit**

Note	Wave No.	Wave Name
C 0	809	BdRoom2
C#0	1059	SdBrMTR
D 0	1066	SdBswrAtSt
D#0	1060	SdBrm2St
E 0	1066	SdBswrAtSt
F 0	1053	SnLvRolSt
F#0	734	Castanet
G 0	984	SdHip1St
G#0	732	Stick
A 0	778	BdFKML
A#0	1029	SdRkStk2St
B 0	794	BdFkSonSt
C 1	773	BdFKSt1-2
C#1	1042	SdCIRmSt
D 1	969	SdLdw1St
D#1	742	HandClapSt
E 1	948	SdBhSt1-3
F 1	1227	TomF1St
F#1	1152	HHClF1St
G 1	1227	TomF1St
G#1	1146	HHPd1St
A 1	1224	TomLoSt
A#1	1158	HHOp2St
B 1	1221	TomMdSt
C 2	1221	TomMdSt
C#2	1253	CrashSt
D 2	1218	TomHiSt
D#2	1258	RideSt
E 2	1267	ChinaSt
F 2	1261	CupSt
F#2	715	TambrnHit
G 2	1271	SplashSt
G#2	745	Cowbel1
A 2	1253	CrashSt
A#2	737	Vibraslap
B 2	1258	RideSt
C 3	676	BongoHi1
C#3	679	BongoLo1-3
D 3	663	CongaTip
D#3	662	CongaSlp
E 3	661	CongaOp
F 3	684	TimbaleH1
F#3	684	TimbaleH1
G 3	725	AgogoLo
G#3	725	AgogoLo
A 3	699	Cabasa1
A#3	696	MaracasSlr
B 3	1063	SdBswrSt
C 4	1063	SdBswrSt
C#4	728	GuiroShort
D 4	727	GuiroLong
D#4	735	Clave
E 4	736	WoodBlock
F 4	736	WoodBlock
F#4	674	CuicaHi
G 4	673	CuicaLo
G#4	741	TriangleMt
A 4	740	TriangleOp
A#4	706	Shaker2
B 4	750	SleighBel
C 5	751	BellTree
C#5	940	SdBIL1-3
D 5	895	SdFkAySt
D#5	956	SdBHR1-3
E 5	934	SdBIS1-2
F 5	786	BdLoL
F#5	1021	SdLdwHMono
G 5	804	BdDry2
G#5	1066	SdBswrAtSt
A 5	859	BdSlimy
A#5	1056	SdRollMono
B 5	772	BdNm2R
C 6	1256	Crash

**PRE 28 Hip Hop3**

Note	Wave No.	Wave Name
C 0	1081	SdT8Rim
C#0	554	VoxHitRev
D 0	560	TurnTable
D#0	540	StabHard
E 0	585	ScratchVoR
F 0	1056	SdRkRollMono
F#0	762	ClaveT8
G 0	989	SdHip1R
G#0	1035	SdHpStk4
A 0	824	BdAnCR
A#0	1105	SdHipRm3
B 0	815	BdT9-3
C 1	836	BdHipDp
C#1	1036	SdHpStk5
D 1	1102	SdHipRm3
D#1	744	HandClapR
E 1	1129	SdLofi
F 1	1247	TomT8
F#1	1208	HHClHip
G 1	1247	TomT8
G#1	1209	HHPd1Hip
A 1	1247	TomT8
A#1	1210	HHOpHip
B 1	1247	TomT8
C 2	1247	TomT8
C#2	1257	Crash2
D 2	1247	TomT8
D#2	1260	RideR
E 2	1275	CrashT8
F 2	1277	RideT9
F#2	759	TambrnRX5
G 2	1273	SplashR
G#2	748	MamboBdy
A 2	1274	CrashT9
A#2	737	Vibraslap
B 2	1277	RideT9
C 3	675	BongoHi1-2
C#3	679	BongoLo1-3
D 3	663	CongaTip
D#3	662	CongaSlp
E 3	661	CongaOp
F 3	683	TmbaleH1-3
F#3	687	TmbaleL1-3
G 3	724	AgogoHi
G#3	725	AgogoLo
A 3	707	ShakerHip1
A#3	696	MaracasSlr
B 3	738	Whistle
C 4	738	Whistle
C#4	728	GuiroShort
D 4	727	GuiroLong
D#4	735	Clave
E 4	736	WoodBlock
F 4	736	WoodBlock
F#4	674	CuicaHi
G 4	673	CuicaLo
G#4	741	TriangleMt
A 4	740	TriangleOp
A#4	704	Shaker1-2
B 4	750	SleighBel
C 5	751	BellTree
C#5	1042	SdCIRmSt
D 5	1088	SdJngl1
D#5	744	HandClapR
E 5	1111	SdBreakHvy
F 5	574	Scratch L
F#5	575	ScratchDwn
G 5	576	ScratchLoF
G#5	578	ScratchHiF
A 5	579	ScratchLoR
A#5	580	ScratchBdR
B 5	581	ScratchSdF
C 6	840	BdBreakHvy

**PRE 29 Hip Hop4**

Note	Wave No.	Wave Name
C 0	1033	SdHpStk2
C#0	553	HiQ2
D 0	560	TurnTable
D#0	536	HitOrch1
E 0	587	ScratchSpn
F 0	1049	SdRkRollR
F#0	762	ClaveT8
G 0	1110	SdBreak3
G#0	1040	SdHpStk7
A 0	835	BdR&B2
A#0	1097	SdR&B1Rm
B 0	816	BdT9-4
C 1	814	BdT9-2
C#1	1034	SdHpStk3
D 1	1105	SdHipRm3
D#1	744	HandClapR
E 1	1106	SdHipRm4
F 1	822	BdT8-3
F#1	1191	HHClT9
G 1	822	BdT8-3
G#1	1192	HHOpT9
A 1	822	BdT8-3
A#1	1192	HHOpT9
B 1	822	BdT8-3
C 2	822	BdT8-3
C#2	1257	Crash2
D 2	822	BdT8-3
D#2	1260	RideR
E 2	1275	CrashT8
F 2	1277	RideT9
F#2	759	TambrnRX5
G 2	1273	SplashR
G#2	748	MamboBdy
A 2	1274	CrashT9
A#2	737	Vibraslap
B 2	1277	RideT9
C 3	675	BongoHi1-2
C#3	679	BongoLo1-3
D 3	663	CongaTip
D#3	662	CongaSlp
E 3	661	CongaOp
F 3	683	TmbaleH1-3
F#3	687	TmbaleL1-3
G 3	724	AgogoHi
G#3	725	AgogoLo
A 3	707	ShakerHip1
A#3	696	MaracasSlr
B 3	738	Whistle
C 4	738	Whistle
C#4	728	GuiroShort
D 4	727	GuiroLong
D#4	735	Clave
E 4	736	WoodBlock
F 4	736	WoodBlock
F#4	674	CuicaHi
G 4	673	CuicaLo
G#4	741	TriangleMt
A 4	740	TriangleOp
A#4	704	Shaker1-2
B 4	750	SleighBel
C 5	751	BellTree
C#5	1042	SdCIRmSt
D 5	1091	SdJnglFX
D#5	744	HandClapR
E 5	1112	SdBreakRol
F 5	577	ScratchLoF
F#5	578	ScratchLoF
G 5	579	ScratchLoF
G#5	580	ScratchLoF
A 5	581	ScratchBdR
A#5	582	ScratchSdF
B 5	583	ScratchStp
C 6	841	BdBreakHrd

**PRE 30 HipStick2**

Note	Wave No.	Wave Name
C 0	1106	SdHipRm4
C#0	549	NzBurst
D 0	560	TurnTable
D#0	543	HitUhh
E 0	581	ScratchBdR
F 0	1055	SnLvRolR
F#0	762	ClaveT8
G 0	1083	SdAnSmRim
G#0	1102	SdHipGate
A 0	815	BdT9-3
A#0	1081	SdT8Rim
B 0	821	BdT8-2
C 1	813	BdT9-1
C#1	1105	SdHipRm3
D 1	1034	SdHpStk3
D#1	744	HandClapR
E 1	1035	SdHpStk4
F 1	1246	TomT9Lo
F#1	1191	HHClT9
G 1	1246	TomT9Lo
G#1	1192	HHOpT9
A 1	1246	TomT9Lo
A#1	1192	HHOpT9
B 1	1245	TomT9Hi
C 2	1245	TomT9Hi
C#2	1257	Crash2
D 2	1245	TomT9Hi
D#2	1260	RideR
E 2	1275	CrashT8
F 2	1277	RideT9
F#2	759	TambrnRX5
G 2	1273	SplashR
G#2	748	MamboBdy
A 2	1274	CrashT9
A#2	737	Vibraslap
B 2	1277	RideT9
C 3	675	BongoHi1-2
C#3	679	BongoLo1-3
D 3	663	CongaTip
D#3	662	CongaSlp
E 3	661	CongaOp
F 3	683	TmbaleH1-3
F#3	687	TmbaleL1-3
G 3	724	AgogoHi
G#3	725	AgogoLo
A 3	707	ShakerHip1
A#3	696	MaracasSlr
B 3	738	Whistle
C 4	738	Whistle
C#4	728	GuiroShort
D 4	727	GuiroLong
D#4	735	Clave
E 4	736	WoodBlock
F 4	736	WoodBlock
F#4	674	CuicaHi
G 4	673	CuicaLo
G#4	741	TriangleMt
A 4	740	TriangleOp
A#4	704	Shaker1-2
B 4	750	SleighBel
C 5	751	BellTree
C#5	1083	SdAnSmRim
D 5	1044	SdCIRmR
D#5	1106	SdHipRm4
E 5	1046	SdCIRm3
F 5	574	Scratch L
F#5	575	ScratchDwn
G 5	576	ScratchHiF
G#5	578	ScratchLoF
A 5	581	ScratchBdR
A#5	591	ScratchCb2
B 5	586	ScratchStp
C 6	828	BdBlpHd



**PRE 31 Garage**

Note	Wave No.	Wave Name
C 0	854	BdHardLong
C#0	813	BdT9-1
D 0	859	BdSlimy
D#0	856	BdAniHard
E 0	845	BdDist4
F 0	835	BdR&B2
F#0	836	BdHipDp
G 0	849	BdFxmHmr
G#0	817	BdT9Hd1
A 0	822	BdT8-3
A#0	852	BdSus
B 0	851	BdZapMid
C 1	821	BdT8-2
C#1	859	BdSlimy
D 1	1076	SdT8-1
D#1	1081	SdT8Rim
E 1	1125	SdClappy
F 1	939	SdB3St
F#1	1149	HHOpSt
G 1	1195	HHClT8-2
G#1	1149	HHOpSt
A 1	1196	HHOpT8-2
A#1	1149	HHOpSt
B 1	1196	HHOpT8-2
C 2	753	ClapAnSm
C#2	1253	CrashSt
D 2	1274	CrashT9
D#2	1258	RideSt
E 2	1277	RideT9
F 2	763	AnaClick
F#2	762	ClaveT8
G 2	753	ClapAnSm
G#2	752	ClapT9
A 2	758	AnaShaker
A#2	754	CongaT8
B 2	754	CongaT8
C 3	1084	SdAnCR
C#3	1047	SdRkRoiSt
D 3	724	AgogoHi
D#3	1308	ChinaRL
E 3	553	HiQ2
F 3	552	HiQ1
F#3	551	Zap2
G 3	550	Zap1
G#3	551	Zap2
A 3	562	DoorSgk
A#3	592	ScratchCb3
B 3	597	FretNoise
C 4	602	PlayFxGt5
C#4	576	ScratchHif
D 4	60	Wurli+
D#4	60	Wurli+
E 4	60	Wurli+
F 4	531	ResoXFade
F#4	534	Sonar1
G 4	545	VoxDrum
G#4	545	VoxDrum
A 4	545	VoxDrum
A#4	1214	HHOpSyn
B 4	1213	HHClSyn
C 5	464	TriWv
C#5	464	TriWv
D 5	464	TriWv
D#5	464	TriWv
E 5	464	TriWv
F 5	464	TriWv
F#5	464	TriWv
G 5	464	TriWv
G#5	464	TriWv
A 5	464	TriWv
A#5	464	TriWv
B 5	464	TriWv
C 6	464	TriWv

**PRE 32 ALL-ROUND**

Note	Wave No.	Wave Name
C 0	854	BdHardLong
C#0	853	BdTekPower
D 0	846	BdDist5
D#0	844	BdDist3
E 0	842	BdDist1
F 0	832	BdD&B1
F#0	827	BdBlip
G 0	823	BdAnSm
G#0	821	BdT8-2
A 0	820	BdT8-1
A#0	819	BdT9Hd3
B 0	814	BdT9-2
C 1	815	BdT9-3
C#1	852	BdSus
D 1	1069	SdT9-1
D#1	1075	SdT9Rim
E 1	1072	SdT9-4
F 1	1246	TomT9Lo
F#1	1191	HHClT9
G 1	1246	TomT9Lo
G#1	1192	HHOpT9
A 1	1246	TomT9Lo
A#1	1192	HHOpT9
B 1	752	ClapT9
C 2	753	ClapAnSm
C#2	1274	CrashT9
D 2	754	CongaT8
D#2	1277	RideT9
E 2	754	CongaT8
F 2	763	AnaClick
F#2	762	ClaveT8
G 2	761	MarcS8
G#2	760	TambrnAnCR
A 2	758	AnaShaker
A#2	755	CowBelT8
B 2	757	CowBelAnCR
C 3	1076	SdT8-1
C#3	1077	SdT8-2
D 3	1078	SdT8-3
D#3	1084	SdAnCR
E 3	1088	SdJngl1
F 3	1092	SdD&B1
F#3	1095	SdD&B4
G 3	1096	SdR&B1
G#3	1098	SdR&B2
A 3	1099	SdHip1
A#3	1127	SdWood
B 3	1126	SdTimber
C 4	1193	HHClT8-1
C#4	1194	HHOpT8-1
D 4	1195	HHClT8-2
D#4	1196	HHOpT8-2
E 4	1146	HHPdISt
F 4	1149	HHOpSt
F#4	1149	HHOpSt
G 4	1211	HHClLoFi
G#4	1212	HHOpLoFi
A 4	1213	HHClSyn
A#4	1214	HHOpSyn
B 4	758	AnaShaker
C 5	759	TambrnRX5
C#5	714	TambrnSw
D 5	746	Cowbell2
D#5	676	BongoHi1
E 5	684	TimbaleHi1
F 5	736	WoodBlock
F#5	854	BdHardLong
G 5	669	TumbaOp
G#5	665	QuintOp
A 5	557	FxGun2
A#5	555	Bomb
B 5	850	BdZapHrd
C 6	589	ScratchHp2

**PRE 33 Rock Multi**

Note	Wave No.	Wave Name
C 0	764	BdNmSt1-2
C#0	1026	SdRkStk1St
D 0	1001	SdRkOp2St
D#0	1047	SdRkRoiSt
E 0	992	SdRkOp1St
F 0	1224	TomLoSt
F#0	1152	HHClF1St
G 0	1224	TomLoSt
G#0	1146	HHPdISt
A 0	1221	TomMdSt
A#0	1149	HHOpSt
B 0	1218	TomHiSt
C 1	800	BdRk2St
C#1	1035	SdRkStk1St
D 1	1021	SdRkOp2St
D#1	742	HandClapSt
E 1	1004	SdRkMte2St
F 1	1236	TomRkLoSt
F#1	1161	HHClRkStSw
G 1	1236	TomRkLoSt
G#1	1170	HHPdRkStSw
A 1	1233	TomRkMdSt
A#1	1179	HHOpRkStSw
B 1	1233	TomRkMdSt
C 2	1230	TomRkHiSt
C#2	1253	CrashSt
D 2	1230	TomRkHiSt
D#2	1258	RideSt
E 2	1267	ChinaSt
F 2	1261	CupSt
F#2	714	TambrnSw
G 2	1271	SplashSt
G#2	745	Cowbel1
A 2	1253	CrashSt
A#2	704	Shaker1-2
B 2	1258	RideSt
C 3	797	BdRk1St
C#3	1029	SdRkStk2St
D 3	992	SdRkOp1St
D#3	752	ClapT9
E 3	995	SdRkMte1St
F 3	1236	TomRkLoSt
F#3	1161	HHClRkStSw
G 3	1236	TomRkLoSt
G#3	1176	HHPdRkSt
A 3	1233	TomRkMdSt
A#3	1181	HHOpRkSt
B 3	1233	TomRkMdSt
C 4	1230	TomRkHiSt
C#4	1253	CrashSt
D 4	1230	TomRkHiSt
D#4	1259	RideL
E 4	1267	ChinaSt
F 4	1261	CupSt
F#4	715	TambrnHit
G 4	1271	SplashSt
G#4	747	MamboBel
A 4	1253	CrashL
A#4	711	ShekereDw
B 4	1260	RideR
C 5	773	BdFkSt1-2
C#5	1026	SdRkStk1St
D 5	998	SdRkRim1St
D#5	1010	SdRkFlmSt
E 5	1007	SdRkRim2St
F 5	1227	TomFlSt
F#5	1135	HHCl4St
G 5	1224	TomLoSt
G#5	1146	HHPdISt
A 5	1221	TomMdSt
A#5	1158	HHOp2St
B 5	1251	TomDistSt
C 6	1218	TomHiSt

**PRE 34 Hip Multi**

Note	Wave No.	Wave Name
C 0	822	BdT8-3
C#0	1081	SdT8Rim
D 0	1121	SdDodgL
D#0	752	ClapT9
E 0	1101	SdHip3
F 0	822	BdT8-3
F#0	1206	HHClT8-3
G 0	822	BdT8-3
G#0	1207	HHOpTek
A 0	822	BdT8-3
A#0	1207	HHOpTek
B 0	822	BdT8-3
C 1	836	BdHipDp
C#1	1035	SdHipStk4
D 1	1103	SdHipRm1
D#1	744	HandClapR
E 1	1100	SdHip2
F 1	1247	TomT8
F#1	1195	HHClT8-2
G 1	1247	TomT8
G#1	1199	HHOpAnCR
A 1	1247	TomT8
A#1	1194	HHOpT8-1
B 1	1247	TomT8
C 2	1247	TomT8
C#2	1274	CrashT9
D 2	1247	TomT8
D#2	1276	CrashSyn
E 2	1276	CrashSyn
F 2	1275	CrashT8
F#2	759	TambrnRX5
G 2	1273	SplashR
G#2	755	CowBelT8
A 2	1274	CrashT9
A#2	757	CowBelAnCR
B 2	1277	RideT9
C 3	836	BdHipDp
C#3	1036	SdHipStk5
D 3	1104	SdHipRm2
D#3	743	HandClapL
E 3	1099	SdHip1
F 3	1246	TomT9Lo
F#3	1197	HHClRX5
G 3	1246	TomT9Lo
G#3	1198	HHClAnCR
A 3	1246	TomT9Lo
A#3	1196	HHOpT8-2
B 3	1245	TomT9Lo
C 4	1245	TomT9Hi
C#4	1255	CrashR
D 4	1245	TomT9Hi
D#4	1275	CrashT8
E 4	1276	CrashSyn
F 4	1275	CrashT8
F#4	715	TambrnHit
G 4	1269	ChinaR
G#4	756	CowBelRX11
A 4	1254	CrashL
A#4	745	Cowbel1
B 4	1260	RideR
C 5	836	BdHipDp
C#5	1041	SdHipStk8
D 5	1102	SdHipGate
D#5	1100	SdHip2
E 5	1107	SdHipRm5
F 5	1252	TomDistLo
F#5	1208	HHClHip
G 5	1252	TomDistLo
G#5	1209	HHPdIHip
A 5	1251	TomDistHi
A#5	1210	HHOpHip
B 5	1251	TomDistHi
C 6	1250	TomAnSm

**PRE 35 Percussion**

Note	Wave No.	Wave Name
C 0	367	Wataiko
C#0	377	Udo Hi
D 0	370	DjembeOp
D#0	667	QuintTip
E 0	378	Udo Low
F 0	376	UdoFinger
F#0	377	Udo Hi
G 0	372	TabraBya
G#0	721	TmbourimOp
A 0	374	TablaMut
A#0	373	TabraNah
B 0	374	TablaMut
C 1	92	Timpani
C#1	543	Hit Uhh
D 1	594	PickNoise1
D#1	752	ClapT9
E 1	741	TriangleMt
F 1	740	TriangleOp
F#1	734	Castanet
G 1	734	Castanet
G#1	734	Castanet
A 1	727	GuiloLong
A#1	728	GuiloShort
B 1	729	GuiloSwp
C 2	737	Vibraslap
C#2	735	Clave
D 2	762	ClaveT8
D#2	673	CaicaLo
E 2	674	CaicaHi
F 2	687	TmbaleL1-3
F#2	736	WoodBlock
G 2	689	TmbaleLo2
G#2	736	WoodBlock
A 2	683	TmbaleH1-3
A#2	749	ChaCha
B 2	685	TmbaleHi2
C 3	691	TmbPailaL
C#3	691	TmbPailaL
D 3	690	TmbPailaH
D#3	747	MamboBel
E 3	679	BongoLo1-3
F 3	682	BongoLo3
F#3	745	Cowbel1
G 3	675	BongoHi1-2
G#3	746	Cowbell2
A 3	678	BongoHHeel
A#3	725	AgogoLo
B 3	724	AgogoHi
C 4	672	TumbaHeel
C#4	671	TumbaTip
D 4	670	TumbaSlp
D#4	696	MaracasStr
E 4	669	TumbaOp
F 4	664	CongaHeel
F#4	663	CongaTip
G 4	662	CongaSlp
G#4	705	Shaker1
A 4	661	CongaOp
A#4	699	Cabasa1
B 4	698	Cabasa1-2
C 5	668	QuintHeel
C#5	667	QuintTip
D 5	666	QuintSlp
D#5	706	Shaker2
E 5	665	QuintOp
F 5	702	Caxixi1
F#5	716	TambrnShk
G 5	715	TambrnHit
G#5	714	TambrnSw
A 5	715	TambrnHit
A#5	750	SleighBel
B 5	738	Whistle
C 6	738	Whistle



**PRE 36 Latin Perc**

Note	Wave No.	Wave Name
C 0	791	BdL_SonSt
C#0	1029	SdRkStk2St
D 0	883	SdFKSt1/3
D#0	1253	CrashSt
E 0	1271	SplashSt
F 0	1224	TomLoSt
F#0	1131	HHClSt1-4
G 0	1224	TomLoSt
G#0	1146	HHPdSt
A 0	1221	TomMdSt
A#0	1149	HHOpSt
B 0	1218	TomHiSt
C 1	671	TumbaTip
C#1	672	TumbaHeel
D 1	670	TumbaStp
D#1	735	Clave
E 1	669	TumbaOp
F 1	663	CongaTip
F#1	664	CongaHeel
G 1	662	CongaSlp
G#1	749	ChaCha
A 1	661	CongaOp
A#1	748	MamboBdy
B 1	747	MamboBel
C 2	667	QuintTip
C#2	668	QuintHeel
D 2	666	QuintSlp
D#2	749	ChaCha
E 2	665	QuintOp
F 2	680	BongoLo1
F#2	678	BongoHHeel
G 2	676	BongoHi1
G#2	688	TimbaleLo1
A 2	691	TmbLPailaL
A#2	684	TimbaleHi1
B 2	690	TmbLPailaH
C 3	736	WoodBlock
C#3	736	WoodBlock
D 3	711	ShekereDw
D#3	712	ShekereUp
E 3	713	ShekereSap
F 3	696	MaracasSir
F#3	697	MaracasStc
G 3	727	GuiroLong
G#3	728	GuiroShort
A 3	729	GuiroSwp
A#3	731	SurdoMt
B 3	730	SurdoOp
C 4	719	PandierTip
C#4	720	PandiroHeel
D 4	718	PandierThm
D#4	717	PandieroOp
E 4	722	TmbourmFng
F 4	723	TmbourimMt
F#4	721	TmbourimOp
G 4	726	AgogoLoTap
G#4	725	AgogoLo
A 4	724	AgogoHi
A#4	740	TriangleOp
B 4	741	TriangleMt
C 5	692	GanzaAc
C#5	693	GanzaBk
D 5	694	GanzaFw
D#5	699	Cabasa1
E 5	700	Cabasa2
F 5	702	Caxixi1
F#5	703	Caxixi2
G 5	673	CuicaLo
G#5	674	CuicaHi
A 5	738	Whistle
A#5	738	Whistle
B 5	737	Vibraslap
C 6	751	BellTree

**PRE 37 Gtr/Bs Fx**

Note	Wave No.	Wave Name
C 0	618	PlayFxAba8
C#0	618	PlayFxAba8
D 0	601	PlayFxAba4
D#0	188	PwrChdMono
E 0	188	PwrChdMono
F 0	619	PlayFxAba9
F#0	595	PickNoise2
G 0	616	PlayFxAba6
G#0	595	PickNoise2
A 0	616	PlayFxAba6
A#0	604	PlayFxAba7
B 0	622	PlyFxAba1H
C 1	643	PlyFxAba2S
C#1	614	PlayFxAba4
D 1	600	PlayFxAba3
D#1	619	PlayFxAba9
E 1	602	PlayFxAba5
F 1	623	PlyFxAba2S
F#1	595	PickNoise2
G 1	623	PlyFxAba2S
G#1	595	PickNoise2
A 1	623	PlyFxAba2S
A#1	597	FretNoise
B 1	623	PlyFxAba2S
C 2	623	PlyFxAba2S
C#2	657	PlyFxAba1H9S
D 2	623	PlyFxAba2S
D#2	595	PickNoise2
E 2	657	PlyFxAba1H9S
F 2	595	PickNoise2
F#2	624	PlyFxAba2H
G 2	657	PlyFxAba1H9S
G#2	609	PlayFxAba12
A 2	657	PlyFxAba1H9S
A#2	655	PlyFxAba1H8S
B 2	595	PickNoise2
C 3	614	PlayFxAba4
C#3	614	PlayFxAba4
D 3	612	PlayFxAba2
D#3	613	PlayFxAba3
E 3	611	PlayFxAba1
F 3	618	PlayFxAba8
F#3	618	PlayFxAba8
G 3	618	PlayFxAba8
G#3	618	PlayFxAba8
A 3	603	PlayFxAba6
A#3	601	PlayFxAba4
B 3	610	PlayFxAba13
C 4	609	PlayFxAba12
C#4	615	PlayFxAba5
D 4	616	PlayFxAba6
D#4	594	PickNoise1
E 4	594	PickNoise1
F 4	596	PickNoise3
F#4	604	PlayFxAba7
G 4	605	PlayFxAba8
G#4	595	PickNoise2
A 4	595	PickNoise2
A#4	600	PlayFxAba3
B 4	655	PlyFxAba1H8S
C 5	606	PlayFxAba9
C#5	607	PlayFxAba10
D 5	608	PlayFxAba11
D#5	598	PlayFxAba1
E 5	599	PlayFxAba2
F 5	600	PlayFxAba3
F#5	601	PlayFxAba4
G 5	653	PlyFxAba1H7S
G#5	634	PlyFxAba1H7H
A 5	633	PlyFxAba1H7S
A#5	656	PlyFxAba1H8H
B 5	657	PlyFxAba1H9S
C 6	659	PlyFxAba1H20S

**PRE 38 Wacko Kit**

Note	Wave No.	Wave Name
C 0	630	PlyFxAba5H
C#0	594	PickNoise1
D 0	1203	HHPdID&B
D#0	743	HandClapL
E 0	584	ScratchVoF
F 0	619	PlayFxAba9
F#0	1127	SdWood
G 0	548	IndusTom
G#0	1117	SdClpAna
A 0	548	IndusTom
A#0	1123	SdFMRim
B 0	812	BdFXGate
C 1	849	BdFXHmr
C#1	614	PlayFxAba4
D 1	1122	SdFM
D#1	743	HandClapL
E 1	1126	SdTimber
F 1	1249	TomSyn2
F#1	1213	HHClSyn
G 1	1249	TomSyn2
G#1	1214	HHOpSyn
A 1	1249	TomSyn2
A#1	1214	HHOpSyn
B 1	1249	TomSyn2
C 2	1249	TomSyn2
C#2	1189	HHOpMono
D 2	534	Sonar1
D#2	1194	HHOpT8-1
E 2	1189	HHOpMono
F 2	1262	CupL
F#2	750	SleighBel
G 2	1196	HHOpT8-2
G#2	513	ResoXFade
A 2	1254	CrashL
A#2	572	RainLoop
B 2	1263	CupR
C 3	516	AirHoseL
C#3	516	AirHoseL
D 3	377	Udo Hi
D#3	426	MgBass2
E 3	427	MgBass3
F 3	618	PlayFxAba8
F#3	618	PlayFxAba8
G 3	725	AgogoLo
G#3	725	AgogoLo
A 3	1217	HHOpHuman
A#3	554	VoxHitRev
B 3	552	HiQ1
C 4	552	HiQ1
C#4	533	LfoSeq
D 4	533	LfoSeq
D#4	505	BellAir
E 4	511	HH Hit
F 4	511	HH Hit
F#4	525	OohFB
G 4	525	OohFB
G#4	528	Mind Bell
A 4	547	Glass
A#4	519	Swarm
B 4	557	FxGun2
C 5	521	Lektronica
C#5	609	PlayFxAba12
D 5	570	Gunshot
D#5	561	Police
E 5	546	Ripper
F 5	604	PlayFxAba7
F#5	556	TapeRevnd
G 5	558	FxGun1
G#5	555	Bomb
A 5	551	Zap2
A#5	549	NzBurst
B 5	539	StabGiant
C 6	538	StabOrch

**PRE 39 Wood Bits**

Note	Wave No.	Wave Name
C 0	762	ClaveT8
C#0	1028	SdHpStk6L
D 0	727	GuiroLong
D#0	1039	SdHpStk6R
E 0	727	GuiroLong
F 0	619	PlayFxAba9
F#0	734	Castanet
G 0	618	PlayFxAba8
G#0	732	Stick
A 0	617	PlayFxAba7
A#0	614	PlayFxAba4
B 0	1245	TomT9Hi
C 1	596	PickNoise3
C#1	1046	SdClRim3
D 1	733	Stick2
D#1	727	GuiroLong
E 1	733	Stick2
F 1	614	PlayFxAba4
F#1	1083	SdAnSmRim
G 1	614	PlayFxAba4
G#1	753	ClapAnSm
A 1	614	PlayFxAba4
A#1	737	Vibraslap
B 1	614	PlayFxAba4
C 2	614	PlayFxAba4
C#2	565	Seashore
D 2	614	PlayFxAba4
D#2	1029	SdRkStk2St
E 2	571	Applause
F 2	1027	SdRkStk1L
F#2	716	TambrnShk
G 2	565	Seashore
G#2	736	WoodBlock
A 2	571	Applause
A#2	564	Helicopter
B 2	1031	SdRkStk2R
C 3	613	PlayFxAba3
C#3	613	PlayFxAba3
D 3	734	Castanet
D#3	734	Castanet
E 3	736	WoodBlock
F 3	691	TmbLPailaL
F#3	691	TmbLPailaL
G 3	732	Stick
G#3	733	Stick2
A 3	701	Caxixi1-2
A#3	703	Caxixi2
B 3	562	DoorSqk
C 4	562	DoorSqk
C#4	728	GuiroShort
D 4	727	GuiroLong
D#4	735	Clave
E 4	736	WoodBlock
F 4	736	WoodBlock
F#4	562	DoorSqk
G 4	562	DoorSqk
G#4	736	WoodBlock
A 4	735	Clave
A#4	562	DoorSqk
B 4	743	HandClapL
C 5	749	ChaCha
C#5	1001	SdRkOp2St
D 5	831	BdJngl3
D#5	666	QuintSlp
E 5	809	BdRoom2
F 5	788	BdHsonSt
F#5	1024	SdHeavy
G 5	614	PlayFxAba4
G#5	1026	SdRkStk1St
A 5	859	BdSlimy
A#5	1019	SdGate1
B 5	794	BdFkSonSt
C 6	811	BdGate

**PRE 40 Metal Bits**

Note	Wave No.	Wave Name
C 0	755	CowBelT8
C#0	1145	HHCl4R
D 0	1263	CupR
D#0	1214	HHOpSyn
E 0	1262	CupL
F 0	1261	CupSt
F#0	446	FMMetal2
G 0	1258	RideSt
G#0	1258	RideSt
A 0	746	Cowbell2
A#0	1132	HHCl1St
B 0	749	ChaCha
C 1	746	Cowbell2
C#1	1213	HHClSyn
D 1	1207	HHOpTek
D#1	1195	HHClT8-2
E 1	1197	HHClRX5
F 1	746	Cowbell2
F#1	1194	HHOpT8-1
G 1	746	Cowbell2
G#1	1213	HHClSyn
A 1	746	Cowbell2
A#1	1214	HHOpSyn
B 1	746	Cowbell2
C 2	746	Cowbell2
C#2	1216	HHOpF2
D 2	746	Cowbell2
D#2	1261	CupSt
E 2	1199	HHOpAnCR
F 2	1261	CupSt
F#2	714	TambrnSw
G 2	1216	HHOpF2
G#2	747	MamboBel
A 2	1216	HHOpF2
A#2	750	SleighBel
B 2	1264	RideMono
C 3	78	Vibraphone
C#3	78	Vibraphone
D 3	82	Tubular
D#3	83	Bell
E 3	86	BrBell
F 3	690	TmbLPailaH
F#3	691	TmbLPailaL
G 3	83	Bell
G#3	83	Bell
A 3	1132	HHCl1St
A#3	1199	HHOpAnCR
B 3	505	BellAir
C 4	504	WindChime
C#4	1184	HHOpRKL
D 4	521	Lektronica
D#4	725	AgogoLo
E 4	745	Cowbell1
F 4	746	Cowbell2
F#4	513	HiLo
G 4	513	HiLo
G#4	741	TriangleMt
A 4	740	TriangleOp
A#4	504	WindChime
B 4	750	SleighBel
C 5	751	BellTree
C#5	87	SmBell
D 5	87	SmBell
D#5	86	BrBell
E 5	88	Hibasi
F 5	76	Harpicord
F#5	1021	SdLdwHMono
G 5	78	Vibraphone
G#5	1022	SdBrRim
A 5	358	Gamelan2
A#5	376	UdoFinger
B 5	89	FingerCym
C 6	83	Bell

**PRE 41 Hands Kit**

Note	Wave No.	Wave Name
C 0	374	TablaMut
C#0	1057	SdBwM2St
D 0	1063	SdBwM2St
D#0	1060	SdBwM2St
E 0	1066	SdBwM2St
F 0	657	PlyFxSI19S
F#0	614	PlayFxAba4
G 0	718	PandierThm
G#0	374	TablaMut
A 0	648	PlyFxAba4
A#0	614	PlayFxAba4
B 0	375	TabraCmb
C 1	367	Wataiko
C#1	667	QuintTip
D 1	1060	SdBwM2St
D#1	742	HandClapSt
E 1	895	SdFkAySt
F 1	378	Udo Low
F#1	374	TablaMut
G 1	378	Udo Low
G#1	372	TabraBya
A 1	377	Udo Hi
A#1	373	TabraNah
B 1	377	Udo Hi
C 2	376	UdoFinger
C#2	1260	RideR
D 2	376	UdoFinger
D#2	1261	CupSt
E 2	1266	CupMono2
F 2	1261	CupSt
F#2	715	TambmHit
G 2	1261	CupSt
G#2	745	Cowbel1
A 2	1264	RideMono
A#2	737	Vibraslap
B 2	1259	RideL
C 3	675	BongoHi1-2
C#3	679	BongoLo1-3
D 3	663	CongaTip
D#3	662	CongaSlp
E 3	661	CongaOp
F 3	683	TmbaleH1-3
F#3	687	TmbaleL1-3
G 3	724	AgogoHi
G#3	725	AgogoLo
A 3	722	TmbourmFng
A#3	722	TmbourmFng
B 3	743	HandClapL
C 4	743	HandClapL
C#4	727	GuiroLong
D 4	727	GuiroLong
D#4	376	UdoFinger
E 4	372	TabraBya
F 4	663	CongaTip
F#4	377	Udo Hi
G 4	377	Udo Hi
G#4	376	UdoFinger
A 4	89	FingerCym
A#4	374	TablaMut
B 4	750	SleighBel
C 5	751	BellTree
C#5	614	PlayFxAba4
D 5	613	PlayFxAba3
D#5	613	PlayFxAba3
E 5	612	PlayFxAba2
F 5	613	PlayFxAba3
F#5	618	PlayFxAba8
G 5	669	TumbaOp
G#5	611	PlayFxAba1
A 5	617	PlayFxAba7
A#5	378	Udo Low
B 5	371	DjembeCmb
C 6	670	TumbaSlp

**PRE 42 Scratches**

Note	Wave No.	Wave Name
C 0	573	Scratch L
C#0	574	Scratch H
D 0	575	ScratchDwn
D#0	576	ScratchHiF
E 0	577	ScratchHiR
F 0	578	ScratchLoF
F#0	579	ScratchLoR
G 0	580	ScratchBdF
G#0	581	ScratchBdR
A 0	582	ScratchSdF
A#0	583	ScratchSdR
B 0	584	ScratchVoF
C 1	573	Scratch H
C#1	574	Scratch L
D 1	575	ScratchDwn
D#1	576	ScratchHiF
E 1	577	ScratchHiR
F 1	578	ScratchLoF
F#1	579	ScratchLoR
G 1	580	ScratchBdF
G#1	581	ScratchBdR
A 1	582	ScratchSdF
A#1	583	ScratchSdR
B 1	584	ScratchVoF
C 2	585	ScratchVoR
C#2	586	ScratchSpn
D 2	587	ScratchStp
D#2	588	ScratchHip
E 2	589	ScratchHp2
F 2	590	ScratchCmb
F#2	591	ScratchCb2
G 2	592	ScratchCb3
G#2	593	ScratchCb4
A 2	573	Scratch H
A#2	574	Scratch L
B 2	575	ScratchDwn
C 3	576	ScratchHiF
C#3	577	ScratchHiR
D 3	578	ScratchLoF
D#3	579	ScratchLoR
E 3	580	ScratchBdF
F 3	581	ScratchBdR
F#3	582	ScratchSdF
G 3	583	ScratchSdR
G#3	584	ScratchVoF
A 3	585	ScratchVoR
A#3	586	ScratchSpn
B 3	587	ScratchStp
C 4	588	ScratchHip
C#4	589	ScratchHp2
D 4	590	ScratchCmb
D#4	591	ScratchCb2
E 4	592	ScratchCb3
F 4	593	ScratchCb4
F#4	573	Scratch H
G 4	574	Scratch L
G#4	575	ScratchDwn
A 4	576	ScratchHiF
A#4	577	ScratchHiR
B 4	578	ScratchLoF
C 5	579	ScratchLoR
C#5	580	ScratchBdF
D 5	581	ScratchBdR
D#5	582	ScratchSdF
E 5	583	ScratchSdR
F 5	584	ScratchVoF
F#5	585	ScratchVoR
G 5	586	ScratchSpn
G#5	587	ScratchStp
A 5	588	ScratchHip
A#5	589	ScratchHp2
B 5	590	ScratchCmb
C 6	591	ScratchCb2

**PRE 43 AcstSnares**

Note	Wave No.	Wave Name
C 0	866	SdNm1St
C#0	867	SdNm2St
D 0	868	SdNm3St
D#0	869	SdNm4St
E 0	884	SdFk1St
F 0	885	SdFk2St
F#0	886	SdFk3St
G 0	895	SdFkAySt
G#0	902	SdBs1St
A 0	903	SdBs2St
A#0	904	SdBs3St
B 0	919	SdSon1St
C 1	920	SdSon2St
C#1	921	SdSon3St
D 1	922	SdSon4St
D#1	937	SdB1St
E 1	938	SdB2St
F 1	939	SdB3St
F#1	952	SdBh1St
G 1	953	SdBh2St
G#1	954	SdBh3St
A 1	969	SdLdw1St
A#1	970	SdLdw2St
B 1	971	SdLdw3St
C 2	972	SdLdw4St
C#2	984	SdHip1St
D 2	985	SdHip2St
D#2	992	SdRkOp1St
E 2	995	SdRkMte1St
F 2	998	SdRkRim1St
F#2	1001	SdRkOp2St
G 2	1004	SdRkMte2St
G#2	1007	SdRkRim2St
A 2	1010	SdRkFlmSt
A#2	992	SdRkOp1St
B 2	995	SdRkMte1St
C 3	998	SdRkRim1St
C#3	1001	SdRkOp2St
D 3	1004	SdRkMte2St
D#3	1007	SdRkRim2St
E 3	1010	SdRkFlmSt
F 3	868	SdNm3St
F#3	895	SdFkAySt
G 3	904	SdBs3St
G#3	921	SdSon3St
A 3	954	SdBh3St
A#3	971	SdLdw3St
B 3	980	SdLdw3R
C 4	1013	SdPicol
C#4	1014	SdPcRim
D 4	1015	SdPcRim2
D#4	1016	SdMid
E 4	1017	SdMdRim
F 4	1018	SdAmb
F#4	1019	SdGate1
G 4	1021	SdLdwHMMono
G#4	1022	SdBwRim
A 4	1023	SdDry
A#4	1024	SdHeavy
B 4	1025	SdGM
C 5	1026	SdRkStk1St
C#5	1029	SdRkStk2St
D 5	1042	SdCIRim1St
D#5	1045	SdCIRim2St
E 5	1046	SdCIRim3St
F 5	1047	SdRkRolSt
F#5	1001	SdRkOp2St
G 5	1053	SnLvRolSt
G#5	920	SdSon2St
A 5	1056	SdRollMono
A#5	971	SdLdw3St
B 5	1057	SdBwM1St
C 6	1066	SdBwM2St

**PRE 44 StSnares**

Note	Wave No.	Wave Name
C 0	860	SdNmSt1-4
C#0	861	SdNmSt1-3
D 0	862	SdNmSt2-4
D#0	863	SdNmSt1-2
E 0	864	SdNmSt2-3
F 0	865	SdNmSt3-4
F#0	866	SdNm1St
G 0	867	SdNm2St
G#0	868	SdNm3St
A 0	869	SdNm4St
A#0	880	SdFkSt1-3
B 0	881	SdFkSt1-2
C 1	882	SdFkSt2-3
C#1	883	SdFkSt1/3
D 1	884	SdFk1St
D#1	885	SdFk2St
E 1	886	SdFk3St
F 1	895	SdFkAySt
F#1	898	SdBsSt1-3
G 1	899	SdBsSt1-2
G#1	900	SdBsSt2-3
A 1	901	SdBsSt1/3
A#1	902	SdBs1St
B 1	903	SdBs2St
C 2	904	SdBs3St
C#2	913	SdSonSt1-4
D 2	914	SdSonSt1-3
D#2	915	SdSonSt2-4
E 2	916	SdSonSt1-2
F 2	917	SdSonSt2-3
F#2	918	SdSonSt3-4
G 2	919	SdSon1St
G#2	920	SdSon2St
A 2	921	SdSon3St
A#2	922	SdSon4St
B 2	933	SdB1St1-3
C 3	934	SdB1St1-2
C#3	935	SdB1St2-3
D 3	936	SdB1St1/3
D#3	937	SdB1St
E 3	938	SdB2St
F 3	939	SdB3St
F#3	948	SdBhSt1-3
G 3	949	SdBhSt1-2
G#3	950	SdBhSt2-3
A 3	951	SdBhSt1/3
A#3	952	SdBh1St
B 3	953	SdBh2St
C 4	954	SdBh3St
C#4	963	SdLdwSt1-4
D 4	964	SdLdwSt1-3
D#4	965	SdLdwSt2-4
E 4	966	SdLdwSt1-2
F 4	967	SdLdwSt2-3
F#4	968	SdLdwSt3-4
G 4	969	SdLdw1St
G#4	970	SdLdw2St
A 4	971	SdLdw3St
A#4	972	SdLdw4St
B 4	984	SdHip1St
C 5	992	SdRkOp1St
C#5	995	SdRkMte1St
D 5	998	SdRkRim1St
D#5	1001	SdRkOp2St
E 5	1004	SdRkMte2St
F 5	1007	SdRkRim2St
F#5	1010	SdRkFlmSt
G 5	1047	SdRkRolSt
G#5	920	SdSon2St
A 5	1050	SdRkRolDSt
A#5	1001	SdRkOp2St
B 5	1053	SnLvRolSt
C 6	868	SdNm3St

**PRE 45 AllKicks**

Note	Wave No.	Wave Name
C 0	764	BdNmSt1-2
C#0	765	BdNm1St
D 0	766	BdNm2St
D#0	767	BdNmL1-2
E 0	773	BdFkSt1-2
F 0	774	BdFk1St
F#0	775	BdFk2St
G 0	782	BdHiSt
G#0	785	BdLoSt
A 0	788	BdHsonSt
A#0	791	BdLsonSt
B 0	794	BdFkSonSt
C 1	797	BdRk1St
C#1	800	BdRk2St
D 1	803	BdDry1
D#1	804	BdDry2
E 1	805	BdPop
F 1	806	BdVar1
F#1	807	BdVar2
G 1	808	BdRoom1
G#1	809	BdRoom2
A 1	810	BdRoom3
A#1	811	BdGate
B 1	812	BdFXGate
C 2	813	BdT9-1
C#2	814	BdT9-2
D 2	815	BdT9-3
D#2	816	BdT9-4
E 2	817	BdT9Hd1
F 2	818	BdT9Hd2
F#2	819	BdT9Hd3
G 2	820	BdT8-1
G#2	821	BdT8-2
A 2	822	BdT8-3
A#2	823	BdAnSm
B 2	824	BdAnCR
C 3	825	BdHuman1
C#3	826	BdHuman2
D 3	827	BdBlip
D#3	828	BdBpHd
E 3	829	BdJngl1
F 3	830	BdJngl2
F#3	831	BdJngl3
G 3	832	BdD&B1
G#3	833	BdD&B2
A 3	834	BdR&B1
A#3	835	BdR&B2
B 3	836	BdHipDp
C 4	837	BdBkDp
C#4	838	BdBk1St
D 4	839	BdBk2St
D#4	840	BdBk3St
E 4	841	BdBk4St
F 4	842	BdDist1
F#4	843	BdDist2
G 4	844	BdDist3
G#4	845	BdDist4
A 4	846	BdDist5
A#4	847	BdDistRM
B 4	848	Bd+HH
C 5	849	BdFxmHr
C#5	850	BdZapHrd
D 5	851	BdZapMid
D#5	852	BdSus
E 5	853	BdTekPower
F 5	854	BdHardLong
F#5	855	BdATite
G 5	856	BdAnHard
G#5	857	BdLofi
A 5	858	BdThkSkn
A#5	859	BdSlimy
B 5	859	BdSlimy
C 6	859	BdSlimy

**PRE 46 DanceKicks**

Note	Wave No.	Wave Name
C 0	813	BdT9-1
C#0	813	BdT9-1
D 0	814	BdT9-2
D#0	815	BdT9-3
E 0	815	BdT9-3
F 0	816	BdT9-4
F#0	817	BdT9Hd1
G 0	818	BdT9Hd2
G#0	819	BdT9Hd3
A 0	819	BdT9Hd3
A#0	854	BdHardLong
B 0	824	BdAnCR
C 1	813	BdT9-1
C#1	814	BdT9-2
D 1	815	BdT9-3
D#1	816	BdT9-4
E 1	817	BdT9Hd1
F 1	818	BdT9Hd2
F#1	819	BdT9Hd3
G 1	820	BdT8-1
G#1	821	BdT8-2
A 1	822	BdT8-3
A#1	823	BdAnSm
B 1	824	BdAnCR
C 2	825	BdHuman1
C#2	826	BdHuman2
D 2	827	BdBlip
D#2	828	BdBlipHd
E 2	829	BdJngl1
F 2	830	BdJngl2
F#2	831	BdJngl3
G 2	832	BdD&B1
G#2	833	BdD&B2
A 2	834	BdR&B1
A#2	835	BdR&B2
B 2	836	BdHipDp
C 3	837	BdBrkDp
C#3	838	BdBreak1
D 3	839	BdBreak2
D#3	840	BdBreakHvy
E 3	841	BdBreakHrd
F 3	842	BdDist1
F#3	843	BdDist2
G 3	844	BdDist3
G#3	845	BdDist4
A 3	846	BdDist5
A#3	847	BdDistRM
B 3	848	Bd+HH
C 4	849	BdFxFHmr
C#4	850	BdZapHrd
D 4	851	BdZapMid
D#4	852	BdSus
E 4	853	BdTekPower
F 4	854	BdHardLong
F#4	855	BdATite
G 4	856	BdAnHard
G#4	857	BdLofi
A 4	858	BdThkSkn
A#4	859	BdSlimy
B 4	811	BdGate
C 5	812	BdFXGate
C#5	813	BdT9-1
D 5	814	BdT9-2
D#5	815	BdT9-3
E 5	816	BdT9-4
F 5	817	BdT9Hd1
F#5	818	BdT9Hd2
G 5	819	BdT9Hd3
G#5	828	BdBlpHd
A 5	835	BdR&B2
A#5	851	BdZapMid
B 5	854	BdHardLong
C 6	855	BdATite

**PRE 47 Snare & Fx**

Note	Wave No.	Wave Name
C 0	1113	SdFx1
C#0	1114	SdFx2
D 0	1115	SdFx3
D#0	1116	SdFx4
E 0	1118	SdDist
F 0	1119	SdCut
F#0	1120	SdDodgH
G 0	1121	SdDodgL
G#0	1122	SdFM
A 0	1124	SdSyn
A#0	1128	SdHammer
B 0	1129	SdLofi
C 1	1069	SdT9-1
C#1	1070	SdT9-2
D 1	1071	SdT9-3
D#1	1072	SdT9-4
E 1	1073	SdT9-5
F 1	1074	SdT9Gate
F#1	1076	SdT8-1
G 1	1077	SdT8-2
G#1	1078	SdT8-3
A 1	1079	SdT8-4
A#1	1080	SdT8-5
B 1	1082	SdAnSm
C 2	1084	SdAnCR
C#2	1086	SdHuman1
D 2	1088	SdJngl1
D#2	1089	SdJngl2
E 2	1090	SdJngl3
F 2	1091	SdJnglFx
F#2	1092	SdD&B1
G 2	1093	SdD&B2
G#2	1094	SdD&B3
A 2	1095	SdD&B4
A#2	1096	SdR&B1
B 2	1097	SdR&B1Rm
C 3	1098	SdR&B2
C#3	1099	SdHip1
D 3	1100	SdHip2
D#3	1101	SdHip3
E 3	1102	SdHipGate
F 3	1103	SdHipRm1
F#3	1104	SdHipRm2
G 3	1105	SdHipRm3
G#3	1106	SdHipRm4
A 3	1107	SdHipRm5
A#3	1109	SdBreak2
B 3	1111	SdBreakHvy
C 4	598	PlayFxFt1
C#4	602	PlayFxFt5
D 4	609	PlayFxFt12
D#4	611	PlayFxAba1
E 4	618	PlayFxAba8
F 4	596	PickNoise3
F#4	573	Scratch H
G 4	574	Scratch L
G#4	575	ScratchDwn
A 4	576	ScratchHf
A#4	586	ScratchStp
B 4	587	ScratchSpn
C 5	546	Ripper
C#5	549	NzBurst
D 5	550	Zap1
D#5	551	Zap2
E 5	552	HiQ1
F 5	553	HiQ2
F#5	555	Bomb
G 5	558	FxGun1
G#5	510	Electer
A 5	511	HH Hit
A#5	520	Mother
B 5	544	HitOrch2
C 6	539	StabGiant

**PRE 48 EasySnares**

Note	Wave No.	Wave Name
C 0		
C#0		
D 0		
D#0		
E 0		
F 0		
F#0		
G 0		
G#0		
A 0		
A#0		
B 0		
C 1	1053	SnLvRolSt
C#1	1066	SdBswrAtSt
D 1	1063	SdBswrSt
D#1	1060	SdBrm2St
E 1	1057	SdBrmSt
F 1	1042	SdCIRmSt
F#1	1042	SdCIRmSt
G 1	884	SdFk1St
G#1	884	SdFk1St
A 1	884	SdFk1St
A#1	885	SdFk2St
B 1	885	SdFk2St
C 2	886	SdFk3St
C#2	886	SdFk3St
D 2	937	SdB1St
D#2	938	SdB2St
E 2	938	SdB2St
F 2	939	SdB3St
F#2	939	SdB3St
G 2	866	SdNm1St
G#2	867	SdNm2St
A 2	867	SdNm2St
A#2	868	SdNm3St
B 2	868	SdNm3St
C 3	869	SdNm4St
C#3	869	SdNm4St
D 3	984	SdHip1St
D#3	984	SdHip1St
E 3	984	SdHip1St
F 3	985	SdHip2St
F#3	985	SdHip2St
G 3	919	SdSon1St
G#3	920	SdSon2St
A 3	920	SdSon2St
A#3	921	SdSon3St
B 3	921	SdSon3St
C 4	922	SdSon4St
C#4	922	SdSon4St
D 4	902	SdBs1St
D#4	903	SdBs2St
E 4	903	SdBs2St
F 4	904	SdBs3St
F#4	904	SdBs3St
G 4	969	SdLdw1St
G#4	970	SdLdw2St
A 4	970	SdLdw2St
A#4	971	SdLdw3St
B 4	971	SdLdw3St
C 5	972	SdLdw4St
C#5	972	SdLdw4St
D 5	952	SdBh1St
D#5	953	SdBh2St
E 5	953	SdBh2St
F 5	954	SdBh3St
F#5	954	SdBh3St
G 5	742	HandClapSt
G#5	752	ClapT9
A 5	753	ClapAnSm
A#5	732	Stick
B 5	733	Stick2
C 6	895	SdFkAySt

**USER 1 RockMono2**

Note	Wave No.	Wave Name
C 0	763	AnaClick
C#0	1058	SdBrMtl
D 0	1064	SdBrSwrL
D#0	1061	SdBrMtl2L
E 0	1067	SdBrSwrAtL
F 0	1064	SnLvRoL
F#0	734	Castanet
G 0	978	SdLdw2R
G#0	732	Stick
A 0	805	BdPop
A#0	981	SdLdw4L
B 0	772	BdNm2R
C 1	803	BdDry1
C#1	1044	SdCIRmR
D 1	941	SdBIR1-3
D#1	743	HandClapL
E 1	974	SdLdwR1-4
F 1	1237	TomRkLoL
F#1	1175	HHClRk2R
G 1	1237	TomRkLoL
G#1	1178	HHPdIRkR
A 1	1234	TomRkMdL
A#1	1185	HHOpRkR
B 1	1234	TomRkMdL
C 2	1232	TomRkHIR
C#2	1254	CrashL
D 2	1232	TomRkHIR
D#2	1260	RideR
E 2	1269	ChinaR
F 2	1263	CupR
F#2	759	TambrnRX5
G 2	1273	SplashR
G#2	745	Cowbel1
A 2	1254	CrashL
A#2	737	Vibraslap
B 2	1264	RideMono
C 3	675	BongoHI1-2
C#3	679	BongoLo1-3
D 3	663	CongaTip
D#3	662	CongaSlp
E 3	661	CongaOp
F 3	683	TmbaleH1-3
F#3	687	TmbaleL1-3
G 3	724	AgogoHi
G#3	725	AgogoLo
A 3	698	Cabasa1-2
A#3	696	MaracasSlr
B 3	738	Whistle
C 4	738	Whistle
C#4	728	GuroShort
D 4	727	GuroLong
D#4	735	Clave
E 4	736	WoodBlock
F 4	736	WoodBlock
F#4	674	CuicaHi
G 4	673	CuicaLo
G#4	741	TriangleMt
A 4	740	TriangleOp
A#4	704	Shaker1-2
B 4	750	SleighBel
C 5	751	BellTree
C#5	1030	SdRkStk2L
D 5	1017	SdMdRim
D#5	991	SdHip2R
E 5	1016	SdMid
F 5	808	BdRoom1
F#5	979	SdLdw3L
G 5	836	BdHipDp
G#5	982	SdLdw4R
A 5	790	BdHsonR
A#5	993	SdRkOp1L
B 5	805	BdPop
C 6	809	BdRoom2

**USER 2 RockMono3**

Note	Wave No.	Wave Name
C 0	763	AnaClick
C#0	1058	SdBrMtl
D 0	1064	SdBrSwrL
D#0	1061	SdBrMtl2L
E 0	1067	SdBrSwrAtL
F 0	1064	SnLvRoL
F#0	734	Castanet
G 0	973	SdLdwL1-4
G#0	732	Stick
A 0	803	BdDry1
A#0	1017	SdMdRim
B 0	807	BdVar2
C 1	810	BdRoom3
C#1	1044	SdCIRmR
D 1	1016	SdMid
D#1	743	HandClapL
E 1	1024	SdHeavy
F 1	1242	TmDryLo
F#1	1188	HHClMono
G 1	1242	TmDryLo
G#1	1190	HHPdIMono
A 1	1241	TomDryHi
A#1	1189	HHOpMono
B 1	1241	TomDryHi
C 2	1241	TomDryHi
C#2	1254	CrashL
D 2	1241	TomDryHi
D#2	1260	RideR
E 2	1267	ChinaSt
F 2	1263	CupR
F#2	759	TambrnRX5
G 2	1273	SplashR
G#2	745	Cowbel1
A 2	1254	CrashL
A#2	737	Vibraslap
B 2	1264	RideMono
C 3	675	BongoHI1-2
C#3	679	BongoLo1-3
D 3	663	CongaTip
D#3	662	CongaSlp
E 3	661	CongaOp
F 3	683	TmbaleH1-3
F#3	687	TmbaleL1-3
G 3	724	AgogoHi
G#3	725	AgogoLo
A 3	698	Cabasa1-2
A#3	696	MaracasSlr
B 3	738	Whistle
C 4	738	Whistle
C#4	728	GuroShort
D 4	727	GuroLong
D#4	735	Clave
E 4	736	WoodBlock
F 4	736	WoodBlock
F#4	674	CuicaHi
G 4	673	CuicaLo
G#4	741	TriangleMt
A 4	740	TriangleOp
A#4	704	Shaker1-2
B 4	750	SleighBel
C 5	751	BellTree
C#5	1032	SdHpStk1
D 5	1024	SdHeavy
D#5	1013	SdPicol
E 5	1021	SdLdwHMono
F 5	802	BdRk2R
F#5	1017	SdMdRim
G 5	835	BdR&B2
G#5	1019	SdGate1
A 5	773	BdFkSt1-2
A#5	1014	SdPcRim
B 5	778	BdFkML
C 6	809	BdRoom2

**USER 3 Hip Hop5**

Note	Wave No.	Wave Name
C 0	1032	SdHpStk1
C#0	552	HiQ1
D 0	560	TurnTable
D#0	543	Hit Uhh
E 0	586	ScratchStp
F 0	1054	SnLvRolL
F#0	762	ClaveT8
G 0	1119	SdCut
G#0	1028	SnRkStk1R
A 0	814	BdT9-2
A#0	1103	SdHipRm1
B 0	820	BdT8-1
C 1	837	BdBrkDp
C#1	1046	SdClRim3
D 1	1104	SdHipRm2
D#1	744	HandClapR
E 1	1096	SdR&B1
F 1	754	CongaT8
F#1	1202	HHClT8-1
G 1	754	CongaT8
G#1	1203	HHOpT8-1
A 1	754	CongaT8
A#1	1204	HHOpT8-1
B 1	754	CongaT8
C 2	754	CongaT8
C#2	1257	Crash2
D 2	754	CongaT8
D#2	1260	RideR
E 2	1275	CrashT8
F 2	1277	RideT9
F#2	759	TambrnRX5
G 2	1273	SplashR
G#2	748	MamboBdy
A 2	1274	CrashT9
A#2	737	Vibraslap
B 2	1277	RideT9
C 3	675	BongoHi1-2
C#3	679	BongoLo1-3
D 3	663	CongaTip
D#3	662	CongaSlp
E 3	661	CongaOp
F 3	683	TmbaleH1-3
F#3	687	TmbaleL1-3
G 3	724	AgogoHi
G#3	725	AgogoLo
A 3	707	ShakerHip1
A#3	696	MaracasSlr
B 3	738	Whistle
C 4	738	Whistle
C#4	728	GuiroShort
D 4	727	GuiroLong
D#4	735	Clave
E 4	736	WoodBlock
F 4	736	WoodBlock
F#4	674	CuicaHi
G 4	673	CuicaLo
G#4	741	TriangleMt
A 4	740	TriangleOp
A#4	704	Shaker1-2
B 4	750	SleighBel
C 5	751	BellTree
C#5	1044	SdClRmR
D 5	1083	SdAnSmRim
D#5	742	HandClapSt
E 5	1101	SdHip3
F 5	583	ScratchSdR
F#5	588	ScratchHip
G 5	581	ScratchBdR
G#5	585	ScratchVoR
A 5	589	ScratchHp2
A#5	591	ScratchCb2
B 5	593	ScratchCb4
C 6	836	BdHipDp

**USER 4 Hip Hop6**

Note	Wave No.	Wave Name
C 0	1032	SdHpStk1
C#0	551	Zap2
D 0	560	TurnTable
D#0	546	Ripper
E 0	589	ScratchHp2
F 0	1054	SnLvRolL
F#0	762	ClaveT8
G 0	1109	SdBREAK2
G#0	1030	SdRkStk2L
A 0	808	BdRoom1
A#0	1101	SdHip3
B 0	815	BdT9-3
C 1	834	BdR&B1
C#1	1030	SdRkStk2L
D 1	1099	SdHip1
D#1	744	HandClapR
E 1	1100	SdHip2
F 1	754	CongaT8
F#1	1208	HHClHip
G 1	754	CongaT8
G#1	1209	HHPdHip
A 1	754	CongaT8
A#1	1210	HHOpHip
B 1	754	CongaT8
C 2	754	CongaT8
C#2	1257	Crash2
D 2	754	CongaT8
D#2	1260	RideR
E 2	1275	CrashT8
F 2	1277	RideT9
F#2	759	TambrnRX5
G 2	1273	SplashR
G#2	748	MamboBdy
A 2	1274	CrashT9
A#2	737	Vibraslap
B 2	1277	RideT9
C 3	675	BongoHi1-2
C#3	679	BongoLo1-3
D 3	663	CongaTip
D#3	662	CongaSlp
E 3	661	CongaOp
F 3	683	TmbaleH1-3
F#3	687	TmbaleL1-3
G 3	724	AgogoHi
G#3	725	AgogoLo
A 3	707	ShakerHip1
A#3	696	MaracasSlr
B 3	738	Whistle
C 4	738	Whistle
C#4	728	GuiroShort
D 4	727	GuiroLong
D#4	735	Clave
E 4	736	WoodBlock
F 4	736	WoodBlock
F#4	674	CuicaHi
G 4	673	CuicaLo
G#4	741	TriangleMt
A 4	740	TriangleOp
A#4	704	Shaker1-2
B 4	750	SleighBel
C 5	751	BellTree
C#5	1046	SdClRim3
D 5	1082	SdAnSm
D#5	742	HandClapSt
E 5	1098	SdR&B2
F 5	573	Scratch H
F#5	574	Scratch L
G 5	575	ScratchDwn
G#5	576	ScratchHif
A 5	577	ScratchHiR
A#5	578	ScratchLoF
B 5	579	ScratchLoR
C 6	830	BdJngl2

**USER 5 T9HipKit2**

Note	Wave No.	Wave Name
C 0	762	ClaveT8
C#0	1073	SdT9-5
D 0	560	TurnTable
D#0	532	Quiek
E 0	592	ScratchCb3
F 0	1054	SnLvRolL
F#0	763	AnaClick
G 0	1074	SdT9Gate
G#0	1085	SdAnCRRim
A 0	819	BdT9Hd3
A#0	1070	SdT9-2
B 0	818	BdT9Hd2
C 1	817	BdT9Hd1
C#1	1075	SdT9Rim
D 1	1069	SdT9-1
D#1	752	ClapT9
E 1	1073	SdT9-5
F 1	1246	TomT9Lo
F#1	1191	HHClT9
G 1	1246	TomT9Lo
G#1	1192	HHOpT9
A 1	1246	TomT9Lo
A#1	1192	HHOpT9
B 1	1246	TomT9Lo
C 2	1245	TomT9Hi
C#2	1274	CrashT9
D 2	1245	TomT9Hi
D#2	1277	RideT9
E 2	1274	CrashT9
F 2	1277	RideT9
F#2	759	TambrnRX5
G 2	1274	CrashT9
G#2	757	CowBelAnCR
A 2	1274	CrashT9
A#2	737	Vibraslap
B 2	1277	RideT9
C 3	675	BongoHi1-2
C#3	679	BongoLo1-3
D 3	663	CongaTip
D#3	662	CongaSlp
E 3	661	CongaOp
F 3	683	TmbaleH1-3
F#3	687	TmbaleL1-3
G 3	724	AgogoHi
G#3	725	AgogoLo
A 3	698	Cabasa1-2
A#3	696	MaracasSlr
B 3	738	Whistle
C 4	738	Whistle
C#4	728	GuiroShort
D 4	727	GuiroLong
D#4	735	Clave
E 4	736	WoodBlock
F 4	736	WoodBlock
F#4	674	CuicaHi
G 4	673	CuicaLo
G#4	741	TriangleMt
A 4	740	TriangleOp
A#4	704	Shaker1-2
B 4	750	SleighBel
C 5	751	BellTree
C#5	1075	SdT9Rim
D 5	1073	SdT9-5
D#5	752	ClapT9
E 5	1072	SdT9-4
F 5	573	Scratch H
F#5	574	Scratch L
G 5	575	ScratchDwn
G#5	576	ScratchHif
A 5	577	ScratchHiR
A#5	578	ScratchLoF
B 5	579	ScratchLoR
C 6	813	BdT9-1

**USER 6 HipStick3**

Note	Wave No.	Wave Name
C 0	1123	SdFMRim
C#0	555	Bomb
D 0	560	TurnTable
D#0	545	VoxDrum
E 0	580	ScratchBdF
F 0	1055	SnLvRolR
F#0	736	WoodBlock
G 0	1085	SdAnCRRim
G#0	1101	SdHip3
A 0	822	BdT8-3
A#0	1075	SdT9Rim
B 0	820	BdT8-1
C 1	814	BdT9-2
C#1	1106	SdHipRm4
D 1	1036	SdHpStk5
D#1	744	HandClapR
E 1	1037	SdHpStk6St
F 1	822	BdT8-3
F#1	1208	HHClHip
G 1	822	BdT8-3
G#1	1209	HHPdHip
A 1	822	BdT8-3
A#1	1210	HHOpHip
B 1	822	BdT8-3
C 2	822	BdT8-3
C#2	1257	Crash2
D 2	822	BdT8-3
D#2	1260	RideR
E 2	1275	CrashT8
F 2	1277	RideT9
F#2	759	TambrnRX5
G 2	1273	SplashR
G#2	748	MamboBdy
A 2	1274	CrashT9
A#2	737	Vibraslap
B 2	1277	RideT9
C 3	675	BongoHi1-2
C#3	679	BongoLo1-3
D 3	663	CongaTip
D#3	662	CongaSlp
E 3	661	CongaOp
F 3	683	TmbaleH1-3
F#3	687	TmbaleL1-3
G 3	724	AgogoHi
G#3	725	AgogoLo
A 3	707	ShakerHip1
A#3	696	MaracasSlr
B 3	738	Whistle
C 4	738	Whistle
C#4	728	GuiroShort
D 4	727	GuiroLong
D#4	735	Clave
E 4	736	WoodBlock
F 4	736	WoodBlock
F#4	674	CuicaHi
G 4	673	CuicaLo
G#4	741	TriangleMt
A 4	740	TriangleOp
A#4	704	Shaker1-2
B 4	750	SleighBel
C 5	751	BellTree
C#5	1083	SdAnSmRim
D 5	1044	SdClRmR
D#5	1106	SdHipRm4
E 5	1045	SdClRim2
F 5	574	Scratch L
F#5	575	ScratchDwn
G 5	576	ScratchHif
G#5	578	ScratchLoF
A 5	581	ScratchBdR
A#5	591	ScratchCb2
B 5	586	ScratchStp
C 6	827	BdBlip

**USER 7 HipStick4**

Note	Wave No.	Wave Name
C 0	1130	SdRimSE
C#0	752	ClapT9
D 0	560	TurnTable
D#0	555	Bomb
E 0	590	ScratchCmb
F 0	1056	SdRollMono
F#0	1075	SdT9Rim
G 0	1105	SdHipRm3
G#0	1088	SdJngl1
A 0	810	BdRoom3
A#0	1038	SdHpStk6L
B 0	815	BdT9-3
C 1	816	BdT9-4
C#1	1106	SdHipRm4
D 1	1040	SdHpStk7
D#1	744	HandClapR
E 1	1041	SdHpStk8
F 1	754	CongaT8
F#1	1206	HHClTek
G 1	754	CongaT8
G#1	1198	HHClAnCR
A 1	754	CongaT8
A#1	1207	HHOpTek
B 1	754	CongaT8
C 2	754	CongaT8
C#2	1257	Crash2
D 2	754	CongaT8
D#2	1260	RideR
E 2	1275	CrashT8
F 2	1277	RideT9
F#2	759	TambrnRX5
G 2	1273	SplashR
G#2	748	MamboBdy
A 2	1274	CrashT9
A#2	737	Vibraslap
B 2	1277	RideT9
C 3	675	BongoHi1-2
C#3	679	BongoLo1-3
D 3	663	CongaTip
D#3	662	CongaSlp
E 3	661	CongaOp
F 3	683	TmbaleH1-3
F#3	687	TmbaleL1-3
G 3	724	AgogoHi
G#3	725	AgogoLo
A 3	707	ShakerHip1
A#3	696	MaracasSlr
B 3	738	Whistle
C 4	738	Whistle
C#4	728	GuiroShort
D 4	727	GuiroLong
D#4	735	Clave
E 4	736	WoodBlock
F 4	736	WoodBlock
F#4	674	CuicaHi
G 4	673	CuicaLo
G#4	741	TriangleMt
A 4	740	TriangleOp
A#4	704	Shaker1-2
B 4	750	SleighBel
C 5	751	BellTree
C#5	1083	SdAnSmRim
D 5	1073	SdT9-5
D#5	1105	SdHipRm3
E 5	1043	SdClRmL
F 5	578	ScratchLoF
F#5	579	ScratchLoR
G 5	580	ScratchBdF
G#5	581	ScratchBdR
A 5	582	ScratchSdF
A#5	583	ScratchSdR
B 5	584	ScratchVoF
C 6	821	BdT8-2

# Performance List

## USER 8 R&B Kit3

Note	Wave No.	Wave Name
C 0	610	PlayFxGI13
C#0	613	PlayFxABa3
D 0	614	PlayFxABa4
D#0	615	PlayFxABa5
E 0	651	PlyFxsH16S
F 0	621	PlyFxsSlp1S
F#0	1279	HHClRL1-4
G 0	764	BdNmSt1-2
G#0	1146	HHPdSt
A 0	860	SdNmSt1-4
A#0	1149	HHOpSt
B 0	822	BdT8-3
C 1	834	BdR&B1
C#1	1046	SdClRim3
D 1	1014	SdPcRim
D#1	742	HandClapSt
E 1	1097	SdB&B1Rm
F 1	822	BdT8-3
F#1	1195	HHClT8-2
G 1	822	BdT8-3
G#1	1193	HHClT8-1
A 1	822	BdT8-3
A#1	1196	HHOpT8-2
B 1	822	BdT8-3
C 2	1247	TomT8
C#2	1253	CrashSt
D 2	1247	TomT8
D#2	1258	RideSt
E 2	1267	ChinaSt
F 2	1261	CupSt
F#2	714	TambrnSw
G 2	1256	Crash
G#2	758	AnaShaker
A 2	758	AnaShaker
A#2	761	Marcst8
B 2	761	Marcst8
C 3	692	GanzaAc
C#3	693	GanzaBk
D 3	694	GanzaFw
D#3	695	Maracas1-2
E 3	696	MaracasSlr
F 3	698	Cabasa1-2
F#3	699	Cabasa1
G 3	700	Cabasa2
G#3	701	Caxixi1-2
A 3	758	AnaShaker
A#3	703	Caxixi2
B 3	704	Shaker1-2
C 4	705	Shaker1
C#4	707	ShakerHip1
D 4	710	ShakerHip4
D#4	762	ClaveT8
E 4	666	QuintSlp
F 4	587	ScratchSpn
F#4	577	ScratchHIR
G 4	576	ScratchHIF
G#4	741	TriangleMt
A 4	740	TriangleOp
A#4	719	PandierTip
B 4	715	TambrnHit
C 5	854	BdHardLong
C#5	1129	SdLofi
D 5	1029	SdRkStk2St
D#5	1013	SdPicol
E 5	560	TurnTable
F 5	1098	SdR&B2
F#5	1152	HHClF1St
G 5	836	BdHipDp
G#5	1155	HHHlf2St
A 5	859	BdSlimy
A#5	1158	HHOp2St
B 5	507	TranCho
C 6	822	BdT8-3

## GM Drum 1 Stereo GM

Note	Wave No.	Wave Name
C 0	735	Clave
C#0	1057	SdBrlMtSt
D 0	1063	SdBrlSwrSt
D#0	1060	SdBrlMt2St
E 0	1066	SdBswrAtSt
F 0	1053	SnLvRolSt
F#0	734	Castanet
G 0	866	SdNm1St
G#0	732	Stick
A 0	773	BdFkSt1-2
A#0	900	SdBsSt2-3
B 0	782	BdHiSt
C 1	764	BdNmSt1-2
C#1	1042	SdClRmSt
D 1	860	SdNmSt1-4
D#1	752	ClapT9
E 1	899	SdBsSt1-2
F 1	1227	TomFISt
F#1	1131	HHClS1-4
G 1	1224	TomLoSt
G#1	1146	HHPdSt
A 1	1224	TomLoSt
A#1	1149	HHOpSt
B 1	1221	TomMdSt
C 2	1221	TomMdSt
C#2	1253	CrashSt
D 2	1218	TomHiSt
D#2	1258	RideSt
E 2	1267	ChinaSt
F 2	1261	CupSt
F#2	714	TambrnSw
G 2	1271	SplashSt
G#2	746	Cowbell2
A 2	1305	CrashRL
A#2	737	Vibraslap
B 2	1306	RideRL
C 3	675	BongoHi1-2
C#3	679	BongoLo1-3
D 3	663	CongaTip
D#3	661	CongaOp
E 3	669	TumbaOp
F 3	683	TmbaleH1-3
F#3	687	TmbaleL1-3
G 3	724	AgogoHi
G#3	725	AgogoLo
A 3	698	Cabasa1-2
A#3	696	MaracasSlr
B 3	738	Whistle
C 4	738	Whistle
C#4	728	GuiroShort
D 4	727	GuiroLong
D#4	735	Clave
E 4	736	WoodBlock
F 4	736	WoodBlock
F#4	674	CuicaHi
G 4	673	CuicaLo
G#4	741	TriangleMt
A 4	740	TriangleOp
A#4	704	Shaker1-2
B 4	750	SleighBel
C 5	751	BellTree
C#5	940	SdBIL1-3
D 5	663	SdLdwSt1-4
D#5	956	SdBhR1-3
E 5	983	SdHipSt1-2
F 5	785	BdLoSt
F#5	1021	SdLdwHMMono
G 5	834	BdR&B1
G#5	1024	SdHeavy
A 5	808	BdRoom1
A#5	1018	SdAmb
B 5	794	BdFkSonSt
C 6	809	BdRoom2

## MSB 63, LSB 64

Number	Performance Name	Category	Sub Category
1	A01 Futurism	Co	SEQ
2	A02 Genesis	Me	MOTION
3	A03 ChurchEns	Or	PIPE
4	A04 JazzGTrio	Co	SPLIT
5	A05 Honky S700	Ap	A.PIANO
6	A06 2001BrsOrc	Br	SECTION
7	A07 RStreet	Co	SEQ
8	A08 GuitarRox	Co	SPLIT
9	A09 AN Split	Co	SEQ
10	A10 SoulSpirit	Co	SPLIT
11	A11 Film Noir	Co	SPLIT
12	A12 Sprinkler	Pd	SOFT
13	A13 LittleBear	Co	SEQ
14	A14 SplitOrgan	Or	ELEC.
15	A15 Dyno+Str	Kb	E.PIANO
16	A16 MovieHero	Co	SPLIT
17	B01 JazzBallad	Co	SPLIT
18	B02 Procession	Co	SEQ
19	B03 Pleiades	Me	MOTION
20	B04 Quartet	St	ENSEMBL
21	B05 SynHeaven	Me	MOTION
22	B06 BluesCruis	Co	SPLIT
23	B07 SmoothMood	Co	SPLIT
24	B08 PopR&B	Co	SPLIT
25	B09 Iron Dance	Co	SEQ
26	B10 GuitarPad	Gt	E.GTR
27	B11 Wnds&Strgs	St	ENSEMBL
28	B12 Classical	Co	SPLIT
29	B13 Hip Balad	Co	SPLIT
30	B14 DeepSea	Me	MOTION
31	B15 Emotion	Co	SEQ
32	B16 Rockn'Hill	Gt	E.GTR
33	C01 GreatWall	Co	SEQ
34	C02 Waterfowl	Me	MOTION
35	C03 JourneyMan	Co	SEQ
36	C04 Ba-PnoCmp	Co	SPLIT
37	C05 Bass'ndrum	Co	SEQ
38	C06 Minoru	St	ENSEMBL
39	C07 Funk Jam	Co	SPLIT
40	C08 Fat Stack	Pd	BRIGHT
41	C09 Spell	Co	SEQ
42	C10 ChinaEns	Co	SPLIT
43	C11 A Visit	Co	SEQ
44	C12 Race	Co	SEQ
45	C13 Mukaiya	Kb	E.PIANO
46	C14 LittleFox	Gt	A.GTR
47	C15 SongWriter	Co	SPLIT
48	C16 Multiplex	Co	SEQ
49	D01 Generation	Co	SEQ
50	D02 SwellIArp	Co	SEQ
51	D03 Orch Theme	St	ENSEMBL
52	D04 Birth	Me	MOTION
53	D05 Heavy Jam	Co	SEQ
54	D06 Utopia	Me	MOTION
55	D07 Islands	Co	SPLIT
56	D08 Romantic	Kb	E.PIANO
57	D09 Afro+House	Co	SEQ
58	D10 Wavepad	Pd	SOFT
59	D11 80AnaSplit	Co	SPLIT
60	D12 Ana Love	Pd	SOFT
61	D13 The Quest	Me	MOTION
62	D14 TradeWinds	Me	MOTION
63	D15 Superstrgs	St	ENSEMBL
64	D16 Flip Hop	Co	SPLIT

Number	Performance Name	Category	Sub Category
65	E01 A dream	Co	SEQ
66	E02 VintString	Gt	E.GTR
67	E03 Motivation	Me	MOTION
68	E04 AsianPad	Me	MOTION
69	E05 Grand+Dyno	Ap	A.PIANO
70	E06 Nast&Clean	Co	SPLIT
71	E07 RareGroove	Co	SPLIT
72	E08 Another	Pd	SOFT
73	E09 Pickin8ths	Gt	E.GTR
74	E10 HiPa Gruv	Me	MOTION
75	E11 ActionFlik	St	ENSEMBL
76	E12 4x4	Co	SPLIT
77	E13 Swirling	Me	MOTION
78	E14 Hot Chili	Co	SEQ
79	E15 Awake	Me	MOTION
80	E16 Latin Jam	Co	SEQ
81	F01 Grand+FM	Ap	A.PIANO
82	F02 My House	Co	SEQ
83	F03 80CompSplt	Co	SPLIT
84	F04 Warm Bell	Pd	SOFT
85	F05 Nobody	Co	SPLIT
86	F06 Mantra	Co	SEQ
87	F07 LoneGitar	Gt	A.GTR
88	F18 Tranzol	Me	MOTION
89	F09 Transfer	Co	SEQ
90	F10 StringSect	St	ENSEMBL
91	F11 Hip	Co	SEQ
92	F12 Jambala	Co	SEQ
93	F13 Rockn'Rave	Co	SEQ
94	F14 OnTheEarth	Co	SPLIT
95	F15 UTAGE	Co	SPLIT
96	F16 Romantic	Ap	A.PIANO
97	G01 Darkside	Co	SPLIT
98	G02 Talitha	Me	MOTION
99	G03 Bebop Trio	Co	SPLIT
100	G04 Hwang Ho	Co	SPLIT
101	G05 Smooove	Co	SEQ
102	G06 Freedom	Co	SEQ
103	G07 Overture	St	ENSEMBL
104	G08 Transform	Co	SEQ
105	G09 MM Brass	Br	SECTION
106	G10 Philharmnc	St	ENSEMBL
107	G11 GuitarMood	Co	SPLIT
108	G12 Insanity	Se	SYNTH
109	G13 LatinFlavr	Dr	PERCUSS
110	G14 Peace	Co	SPLIT
111	G15 Lugosi	Me	MOTION
112	G16 Groovin'EP	Co	SPLIT
113	H01 Arabian	Pd	SOFT
114	H02 70th Heroe	Or	ELEC.
115	H03 Lover	Co	SEQ
116	H04 Solo Gig	Co	SPLIT
117	H05 Sweet Ens	Rp	PIPE
118	H06 AltnaRock	Co	SPLIT
119	H07 LatinBrass	Br	SECTION
120	H08 Ethno Jam	Co	SEQ
121	H09 Stormy	Kb	E.PIANO
122	H10 Book Him	Co	SEQ
123	H11 MonstrLead	Ld	HARD
124	H12 Raga #5	Co	SEQ
125	H13 Ethnoluv	Co	SPLIT
126	H14 BellPPad	Ap	OTHER
127	H15 Coal	Co	SPLIT
128	H16 Velomuv	Me	MOTION



# Wave List

No.	Category	Wave Name	No.	Category	Wave Name	No.	Category	Wave Name	No.	Category	Wave Name	No.	Category	Wave Name	No.	Category	Wave Name			
1	Ap	Piano1 St	101	Or	Jazz	201	Ba	PrecRW	301	Br	F.Horn	401	Wv	VPSrngSt	501	Me	OrchHit	601	Se	PlayFXG4
2	Ap	Piano1 L	102	Or	Jazz+	202	Ba	PrecRW+	302	Br	F.Horn+	402	Wv	VPStrngL	502	Me	VoxBell	602	Se	PlayFXG5
3	Ap	Piano1 R	103	Or	Jazz-	203	Ba	PrecRW-	303	Br	F.Horn-	403	Wv	VPStrngR	503	Me	Melow	603	Se	PlayFXG6
4	Ap	Piano1 Mono	104	Or	Full	204	Ba	PrecFW	304	Br	Tuba	404	Wv	OBStrings	504	Me	WindChime	604	Se	PlayFXG7
5	Ap	Piano1 St+	105	Or	Full+	205	Ba	PrecFW+	305	Br	Combi1	405	Wv	SzyleStrng	505	Me	BellAir	605	Se	PlayFXG8
6	Ap	Piano1 L+	106	Or	Full-	206	Ba	PrecFW-	306	Br	Combi2	406	Wv	Pydze	506	Me	BigSyn	606	Se	PlayFXG9
7	Ap	Piano1 R+	107	Or	Swish	207	Ba	FingerVW	307	Br	Combi3	407	Wv	Darklight	507	Me	TranCho	607	Se	PlayFXG10
8	Ap	Piano1 St-	108	Or	Swish-	208	Ba	FingerVW+	308	Br	Combi4	408	Wv	OBBrass	508	Me	StabOrgLP	608	Se	PlayFXG11
9	Ap	Piano1 L-	109	Or	Compact	209	Ba	FingerVW-	309	Rd	SopranoSax	409	Wv	Sync	509	Me	Eery	609	Se	PlayFXG12
10	Ap	Piano1 R-	110	Or	Compact-	210	Ba	SlapThmbmf	310	Rd	SopranSax+	410	Wv	SyncLd	510	Me	Electer	610	Se	PlayFXG13
11	Ap	Piano2 St	111	Or	Portable	211	Ba	SlapThmbff	311	Rd	SopranSax-	411	Wv	PWMiast	511	Me	HH Hit	611	Se	PlayFXABa1
12	Ap	Piano2 L	112	Or	Portable-	212	Ba	SlapPull	312	Rd	AltoSaxVb	412	Wv	PWMslow	512	Me	VoxAlk	612	Se	PlayFXABa2
13	Ap	Piano2 R	113	Or	BowNv	213	Ba	SlapHarm	313	Rd	AltoSaxNv	413	Wv	CS80Brass	513	Me	HiLo	613	Se	PlayFXABa3
14	Ap	Piano2 Mono	114	Or	BowVb	214	Ba	SlapFxFSoft	314	Rd	AltoSaxNv+	414	Wv	P5Saw	514	Me	MultiPiano	614	Se	PlayFXABa4
15	Ap	Piano2 St+	115	Or	Gospel	215	Ba	SlapFxFHard	315	Rd	AltoSaxNv-	415	Wv	OBSaw	515	Me	AirHoseSt	615	Se	PlayFXABa5
16	Ap	Piano2 L+	116	Or	Soul	216	Ba	Thmb&Fxfmf	316	Rd	TenorSax	416	Wv	Saw2	516	Me	AirHoseL	616	Se	PlayFXABa6
17	Ap	Piano2 R+	117	Or	1stFour	217	Ba	Thmb&Fxf	317	Rd	TenorSax+	417	Wv	3c3Saw	517	Me	AirHoseR	617	Se	PlayFXABa7
18	Ap	Piano2 St-	118	Or	Draw 16'	218	Ba	Pull&Fx	318	Rd	TenorSax-	418	Wv	3c3Saw2	518	Me	Bubble	618	Se	PlayFXABa8
19	Ap	Piano2 L-	119	Or	Draw 5 1/3	219	Ba	Fretless	319	Rd	BaritonSax	419	Wv	3c3Squ	519	Me	Swarm	619	Se	PlayFXABa9
20	Ap	Piano2 R-	120	Or	Draw 8'	220	Ba	Fretless+	320	Rd	Clarinete	420	Wv	1o1Saw	520	Me	Mother	620	Se	PlayFXABa10
21	Ap	Brite Pno	121	Or	Draw 4'	221	Ba	Fretless-	321	Rd	Oboe	421	Wv	1o1Sub	521	Me	Lektronika	621	Se	PlayFXSlp1S
22	Ap	Brite Pno-	122	Or	Draw 2 2/3	222	St	ViolinVb	322	Rd	EnglishHrn	422	Wv	Saw5Qu	522	Me	SpaceScrem	622	Se	PlayFXSlp1H
23	Ap	CP80	123	Or	Draw 2'	223	St	ViolinVb+	323	Rd	Bassoon	423	Wv	SawSaw	523	Me	Resonator	623	Se	PlayFXSlp2S
24	Ap	CP80+	124	Or	Draw 1 3/5	224	St	ViolinVb-	324	Rd	Bagpipe1	424	Wv	MgRamp	524	Me	RadioNz	624	Se	PlayFXSlp2H
25	Ap	CP80-	125	Or	Draw 1 1/3	225	St	ViolinSpc	325	Rd	Bagpipe2	425	Wv	MgBass1	525	Me	QohFwb	625	Se	PlayFXSlp3S
26	Ep	EP1 Soft	126	Or	Draw 1'	226	St	ViolinSpc+	326	Rd	SaxBreath	426	Wv	MgBass2	526	Me	AirWave	626	Se	PlayFXSlp3H
27	Ep	EP1 Soft+	127	Or	Draw 1+3	227	St	ViolinSpc-	327	Rd	Harmonica	427	Wv	MgBass3	527	Me	Hoo	627	Se	PlayFXSlp4S
28	Ep	EP1 Soft-	128	Or	Draw 1+3+	228	St	ViolaVb	328	Pi	FluteVb	428	Wv	ModBass	528	Me	Mind Bell	628	Se	PlayFXSlp4H
29	Ep	EP1 Med	129	Or	Draw 1+3-	229	St	ViolaVb+	329	Pi	FluteVbAtk	429	Wv	AnaBass1	529	Me	Loop145	629	Se	PlayFXSlp5S
30	Ep	EP1 Med+	130	Or	Draw 2+4	230	St	ViolaVb-	330	Pi	Flute	430	Wv	AnaBass2	530	Me	X-Fade	630	Se	PlayFXSlp5H
31	Ep	EP1 Med-	131	Or	Draw 2+4+	231	St	ViolaSpc	331	Pi	Flute+	431	Wv	UniBass	531	Me	ResoXFade	631	Se	PlayFXSlp6S
32	Ep	EP1 Hard	132	Or	Draw 2+4-	232	St	ViolaSpc+	332	Pi	Flute-	432	Wv	AnaBass3	532	Me	Quiet	632	Se	PlayFXSlp6H
33	Ep	EP1 Hard+	133	Or	Draw Even	233	St	ViolaSpc-	333	Pi	PanFlute	433	Wv	AnaBass4	533	Me	LoSeq	633	Se	PlayFXSlp7S
34	Ep	EP1 Hard-	134	Or	Draw Even+	234	St	CelloVb	334	Pi	PanFlute-	434	Wv	AnaBass5	534	Me	Sonar1	634	Se	PlayFXSlp7H
35	Ep	EP2 Soft1	135	Or	Draw Even-	235	St	CelloVb+	335	Pi	Shakuhachi	435	Wv	AnaBass6	535	Me	Sonar2	635	Se	PlayFXSlp8S
36	Ep	EP2 Soft1+	136	Or	Draw Odd	236	St	CelloVb-	336	Pi	Recorder	436	Wv	T&KickBass	536	Me	HitOrch1	636	Se	PlayFXSlp8H
37	Ep	EP2 Soft1-	137	Or	Draw Odd+	237	St	CelloSpc	337	Pi	Bottle	437	Wv	FBass1	537	Me	HitBrass	637	Se	PlayFXSlp9S
38	Ep	EP2 Soft2	138	Or	Draw Odd-	238	St	CelloSpc+	338	Pi	Ocarina	438	Wv	FBass2	538	Me	StabOrch	638	Se	PlayFXSlp9H
39	Ep	EP2 Soft2+	139	Or	Perc	239	St	CelloSpc-	339	Pi	Whistle	439	Wv	FBass3	539	Me	StabGiant	639	Se	PlayFXSlp10S
40	Ep	EP2 Soft2-	140	Or	Perc+	240	St	SoloVbCmb	340	Pi	BreathO.S.	440	Wv	FBass4	540	Me	StabHard	640	Se	PlayFXSlp10H
41	Ep	EP2 Hard1	141	Or	Perc-	241	St	SoloVbCmb+	341	Cp	SteelDrum	441	Wv	FBass5	541	Me	StabOrgan2	641	Se	PlayFXSl11S
42	Ep	EP2 Hard1+	142	Or	Rotar	242	St	SoloVbCmb-	342	Gt	Sitar	442	Wv	FBass6	542	Me	StabAah	642	Se	PlayFXSl11H
43	Ep	EP2 Hard1-	143	Or	Clack	243	St	SoloSpcCmb	343	Gt	SitarWv1	443	Wv	FMSquare	543	Me	Hit Uhh	643	Se	PlayFXSl12S
44	Ep	EP2 Hard2	144	Or	RotarWhstl	244	St	SoloSpcCmb+	344	Gt	SitarWv2	444	Wv	FMShaper	544	Me	HitOrch2	644	Se	PlayFXSl12H
45	Ep	EP2 Hard2+	145	Or	RotarGrit	245	St	SoloSpcCmb-	345	Gt	SitarWv3	445	Wv	FMMetal1	545	Me	VoxDrum	645	Se	PlayFXSl13S
46	Ep	EP2 Hard2-	146	Or	RotarGrit2	246	St	ContraBass	346	Gt	SitarWv4	446	Wv	FMMetal2	546	Se	Ripper	646	Se	PlayFXSl13H
47	Ep	EP3 Soft1	147	Or	SitTimp	247	St	Ensmix	347	Gt	SitarWv5	447	Wv	FMOrgan1	547	Se	Glass	647	Se	PlayFXSl14S
48	Ep	EP3 Soft1+	148	Or	Pipe1St	248	St	EnsmixSt	348	Gt	SitarWv6	448	Wv	FMOrgan2	548	Se	IndusTom	648	Se	PlayFXSl14H
49	Ep	EP3 Soft1-	149	Or	Pipe1L	249	St	EnsmixL	349	Gt	Tamboura	449	Wv	FMOrgan3	549	Se	NzBurst	649	Se	PlayFXSl15S
50	Ep	EP3 Soft2	150	Or	Pipe1R	250	St	EnsmixR	350	Gt	TamburaVv1	450	Wv	FMOrgan4	550	Se	Zap1	650	Se	PlayFXSl15H
51	Ep	EP3 Soft2+	151	Or	Pipe2	251	St	Ensmute	351	Gt	TamburaVv2	451	Wv	FMFunk	551	Se	Zap2	651	Se	PlayFXSl16S
52	Ep	EP3 Soft2-	152	Or	Pipe3St	252	St	Ensmute-	352	Gt	TamburaVv3	452	Wv	FMGuitar	552	Se	HIQ1	652	Se	PlayFXSl16H
53	Ep	EP3 Hard1	153	Or	Pipe3L	253	St	EnsmuteSt	353	Cp	HmDulcimer	453	Wv	FSBuzz	553	Se	HIQ2	653	Se	PlayFXSl17S
54	Ep	EP3 Hard1+	154	Or	Pipe3R	254	St	HardEnsSt	354	Gt	Shamisen	454	Wv	WetPluck	554	Se	PlayFXSl17H			
55	Ep	EP3 Hard1-	155	Or	Pipe4	255	St	HardEnsSt+	355	Gt	Koto	455	Wv	Lately-S	555	Se	Bomb	655	Se	PlayFXSl18S
56	Ep	EP3 Hard2	156	Or	Pipe5	256	St	HardEnsSt-	356	Cp	Kalimba	456	Wv	Lately-L	556	Se	TapeRewnd	656	Se	PlayFXSl18H
57	Ep	EP3 Hard2+	157	Or	Pipe6	257	St	HardEnsL	357	Cp	Gamelan1	457	Wv	P10-1	557	Se	FxGun2	657	Se	PlayFXSl19S
58	Ep	EP3 Hard2-	158	Or	Pipe7	258	St	HardEnsL+	358	Cp	Gamelan2	458	Wv	P10-2	558	Se	FxGun1	658	Se	PlayFXSl19H
59	Ep	Wurli	159	Or	Accordion	259	St	HardEnsL-	359	Pi	Didgerid01	459	Wv	P10-3	559	Se	Thunder	659	Se	PlayFXSl20S
60	Ep	Wurli+	160	Or	TangoAcD	260	St	HardEnsR	360	Pi	Didgerid02	460	Wv	P25-1	560	Se	TurnTable	660	Se	PlayFXSl20H
61	Ep	Wurli-	161	Or	Nylon	261	St	HardEnsR+	361	Pi	Didgerid03	461	Wv	P25-2	561	Se	Police	661	Pc	CongaOp
62	Ep	DX1	162	Gt	Nylon Hi	262	St	HardEnsR-	362	Pi	DidgCmb1	462	Wv	P50-1	562	Se	DoorSgk	662	Pc	CongaSlp
63	Ep	DX2	163	Gt	NylonHarm	263	St	EnsmixLPSt	363	Pi	DidgCmb2	463	Wv	P50-2	563	Se	Heartbeat	663	Pc	CongaTip
64	Ep	DX3	164	Gt	Steel Gtr1	264	St	EnsmixLP L	364	Pi	Sho	464	Wv	TriVw	564	Se	Helicopter	664	Pc	CongaHeel
65	Ep	DX4	165	Gt	SteelGtrHi	265	St	EnsmixLP R	365	Pc	Log1	465	Wv	Digi01	565	Se	Seashore	665	Pc	QuintOp
66	Ep	DX5	166	Gt	SteelGtrLo	266	St	EnsmuteLP	366	Pc	Log2	466	Wv	Digi02	566	Se	Telephone	666	Pc	QuintSlp
67	Kb	Clav1	167	Gt	SteelHarm	267	St	EnsmuteLP-	367	Pc	Wataiko	467	Wv	Digi03	567	Se	TelRing	667	Pc	QuintTip
68	Kb	Clav1+	168	Gt	Steel Gtr2	268	St	EnsmuteLPSt	368	Pc	DjembeEd	468	Wv	Digi04	568	Se	Bird	668	Pc	QuintHeel
69	Kb	Clav1-	169	Gt	SteelGtr2St	269	St	HrdEnsLPSt	369	Pc	DjembeMt	469	Wv	Digi05	569	Se	Stream	669	Pc	TumbaOp
70	Kb	Clav2	170	Gt	SteelGtr2Hi	270	St	HrdEnsLP L	370	Pc	DjembeOp	470	Wv	Digi06	570	Se	Gunshot	670	Pc	TumbaSlp
71	Kb	Clav2+	171	Gt	SteelGtr2-	271	St	HrdEnsLP R	371	Pc	DjembeCmb	471	Wv	Digi07	571	Se	Applause	671	Pc	TumbaTip
72	Kb	Clav2-	172	Gt	Jazz Gtr	272	St	Pizzicato	372	Pc	TablaBya	472	Wv	Digi08	572	Se	RainLoop	672	Pc	TumbaHeel
73	Kb	Clav3	173	Gt	VintAmpA	273	St	PopPizz	373	Pc	TablaNah	473	Wv	Digi09	573	Se	Scratch H	673	Pc	CuicaLo
74	Kb	Clav3+	174	Gt	VintAmpB	274	St	Harp	374	Pc	TablaMnt	474	Wv	Digi10	574	Se	Scratch L	674	Pc	CuicaHi
75	Kb	Clav3-	175	Gt	Strat	275	Br	BrsSctSt	375	Pc	TablaCmb	475	Wv	Digi11	575	Se	ScratchDwn	675	Pc	Bongohi1-2
76	Kb	Harpiscord	176	Gt	Strat															





# Effect Type List

Effect Category	Effect Name	LCD	MIDI (HEX)		No.				
			MSB	LSB	REV	CHO	InsEf1	InsEf2	Var(*)
---	NO EFFECT	off	00	00	0	0			0
---	THRU	Thru	00	00			0	0	
REV									
	HALL 1	Rev Hall 1	01	00	1			1	
	HALL 2	Rev Hall 2	01	01	2			2	
	ROOM 1	Rev Room 1	01	10	3			3	
	ROOM 2	Rev Room 2	01	11	4			4	
	ROOM 3	Rev Room 3	01	12	5			5	
	STAGE 1	Rev Stage 1	01	20	6			6	
	STAGE 2	Rev Stage 2	01	21	7			7	
	PLATE	Rev Plate	01	30	8			8	
	WHITE ROOM	RevWhiteRoom	01	40	9				
	TUNNEL	Rev Tunnel	01	41	10				
	BASEMENT	Rev Basement	01	42	11				
	CANYON	Rev Canyon	01	43	12				
DLY									
	DELAY L,C,R	Delay L,C,R	02	00				9	
	DELAY L,R	Delay L,R	02	10		18		10	
	ECHO	Echo	02	20		19		11	
	CROSS DELAY	Cross Delay	02	30		20		12	
	CONTROL DELAY (MONO)	Ctrl Delay 1	02	40		21		13	
	CONTROL DELAY (STEREO)	Ctrl Delay 2	02	48		22		14	
	TEMPO DELAY (MONO)	TempoDelay 1	02	50		23		15	
	TEMPO DELAY (STEREO)	TempoDelay 2	02	58		24		16	
	TEMPO CROSS DELAY	TempoCrosDly	02	60		25		17	
ER									
	EARLY REFLECTION 1	Early Ref 1	03	00				18	
	EARLY REFLECTION 2	Early Ref 2	03	01				19	
	GATE REVERB	Gate Reverb	03	10				20	
	REVERSE GATE	Reverse Gate	03	20				21	
KAR									
	KARAOKE 1	Karaoke 1	04	00				22	
	KARAOKE 2	Karaoke 2	04	01				23	
	KARAOKE 3	Karaoke 3	04	02				24	
CHO									
	CHORUS 1	Chorus 1	05	00		1	1	25	1
	CHORUS 2	Chorus 2	05	01		2	2	26	2
	CHORUS 3	Chorus 3	05	02		3	3	27	3
	CHORUS 4	Chorus 4	05	08		4	4	28	4
	CHORUS 5	Chorus 5	05	09		5		29	
	CELESTE 1	Celeste 1	05	10		6	5	30	5
	CELESTE 2	Celeste 2	05	11		7	6	31	6
	CELESTE 3	Celeste 3	05	12		8	7	32	7
	CELESTE 4	Celeste 4	05	18		9	8	33	8
	SYMPHONIC	Symphonic	05	20		10		34	
	ENSEMBLE DETUNE	Ensemble	05	30		11		35	
FLG									
	FLANGER 1	Flanger 1	06	00		12	9	36	9
	FLANGER 2	Flanger 2	06	01		13	10	37	10
	FLANGER 3	Flanger 3	06	08		14	11	38	11
	V-FLANGER	V-Flanger	06	10				39	
	TEMPO FLANGER	TempoFlanger	06	50		15		40	
	DYNAMIC FLANGER	DynamFlanger	06	60				41	
PHA									
	PHASER 1	Phaser 1	07	00		16	12	42	12
	PHASER 2	Phaser 2	07	08				43	
	TEMPO PHASER	TempoPhaser	07	50		17		44	
	DYNAMIC PHASER	DynamPhaser	07	60				45	
MOD									
	TREMOLO	Tremolo	08	00			13	46	13
	AUTO PAN	Auto Pan	08	10			14	47	14
	AUTO PAN 2	Auto Pan 2	08	11				48	
	ROTARY SPEAKER	Rotary SP 1	08	50				49	
	DISTORTION+ROTARY SPEAKER	Dist+RotSp1	08	51				50	
	OVERDRIVE+ROTARY SPEAKER	Odrv+RotSp1	08	52				51	
	AMP SIM.+ROTARY SPEAKER	Amp +RotSp1	08	53				52	
	2WAY ROTARY SPEAKER	Rotary Sp2	08	60				53	
	DISTORTION+2WAY ROTARY SPEAKER	Dist+RotSp2	08	61				54	
	OVERDRIVE+2WAY ROTARY SPEAKER	Odrv+RotSp2	08	62				55	
	AMP SIM.+2WAY ROTARY SPEAKER	Amp +RotSp2	08	63				56	
	DUAL ROTOR SPEAKER1	Dual RotSp 1	08	70				57	
	DUAL ROTOR SPEAKER2	Dual RotSp 2	08	71				58	
	DUAL ROTOR SPEAKER3	Dual RotSp 3	08	72				59	

(\*) Performance Mode Only.

Effect Category	Effect Name	LCD	MIDI (HEX)		No.				
			MSB	LSB	REV	CHO	InsEf1	InsEf2	Var(*)
DST									
	DISTORTION	Distortion	09	00			15	60	15
	COMP DISTORTION	Comp + Dist	09	01				61	
	V-DISTORTION	V-Distortion	09	10				62	
	OVER DRIVE	Overdrive	09	20			16	63	16
	AMP SIMULATOR	AmpSimulator	09	30			17	64	17
	AMP SIMULATOR 2	AmpSim 2	09	31			18	65	18
	DIST+DELAY	Dist + Delay	09	40				66	
	OVERDRIVE+DELAY	Odrv + Delay	09	41				67	
DYN									
	COMPRESSOR	Compressor	0A	00			19	68	19
	NOISE GATE	Noise Gate	0A	20			20	69	20
	COMP+DIST+DELAY	Cmp+Dist+Dly	0A	40				70	
	COMP+OVERDRIVE+DELAY	Cmp+Odrv+Dly	0A	41				71	
	MULTI BAND COMPRESSOR 1	MltBndComp 1	0A	50				72	
	MULTI BAND COMPRESSOR 2	MltBndComp 2	0A	51				73	
PCH									
	PITCH CHANGE 1	PitchChange1	0B	00				74	
	PITCH CHANGE 2	PitchChange2	0B	01				75	
WAH									
	AUTO WAH	Auto Wah	0C	00			21	76	21
	AUTO WAH + DIST	A.Wah+Dist	0C	01				77	
	AUTO WAH + OVERDRIVE	A.Wah+Odrv	0C	02				78	
	TOUCH WAH	Touch Wah	0C	10			22	79	22
	TOUCH WAH + DIST	T.Wah+Dist	0C	11				80	
	TOUCH WAH + OVERDRIVE	T.Wah+Odrv	0C	12				81	
	WAH+DIST+DELAY	Wah+Dist+Dly	0C	40				82	
	WAH+OVERDRIVE+DELAY	Wah+Odrv+Dly	0C	41				83	
L-F									
	LO-FI	Lo-Fi	0D	00				84	
	LOW RESOLUTION	LoResolution	0D	10				85	
	NOISY	Noisy	0D	20				86	
	ATTACK LO-FI	Attack LoFi	0D	30				87	
	DIGITAL TURNTABLE	D.Turntable	0D	50				88	
TEC									
	DIGITAL SCRATCH	D.Scratch	0E	00				89	
	AUTO SYNTH	Auto Synth	0E	10				90	
	TECH MODULATION	Tech Mod	0E	20				91	
	JUMP	Jump	0E	30				92	
	ISOLATION	Isolator	0E	40				93	
	SLICE	Slice	0E	50				94	
MSC									
	3-BAND EQ	3 Band EQ	0F	00			23	95	23
	2-BAND EQ	2 Band EQ	0F	01			24	96	24
	HARMONIC ENHANCER	Enhancer	0F	10			25	97	25
	VOICE CANCEL	Voice Cancel	0F	20				98	
	AMBIENCE	Ambience	0F	30				99	
	TALKING MODULATOR	Talking Mod	0F	40				100	
	BEAT CHANGE	Beat Change	0F	50				101	
	RING MODULATOR	Ring Mod	0F	70				102	
	DYNAMIC RING MODULATOR	DynamRingMod	0F	71				103	
	DYNAMIC FILTER	DynamFilter	0F	78				104	

(\*) Performance Mode Only.

# Effect Parameter List

## 1. Reverb

### 01 HALL 1-08 PLATE

No.	Parameter	Range	Value	MIDI Parameter Number	Table
1	Reverb Time	0.3s-30.0s	(0-69)	1	4
2	Initial Delay	0.1ms-200.0ms	(0-127)	3	5
3	Reverb Delay	0.1ms-200.0ms	(0-127)	6	5
4	HPF Cutoff Frequency	20Hz-8.0kHz	(0-52)	4	3
5	LPF Cutoff Frequency	1.0kHz-20.0kHz	(34-60)	5	3
6	Diffusion	0-10	(0-10)	2	
7	Density	0-4	(0-4)	7	
8	ER/Rev Balance	E63>R-E=R-E<R63	(1-127)	8	
9	Feedback Level	-63-+63	(1-127)	10	
10	Feedback High Damp	0.1-1.0	(1-10)	9	

### 09 WHITE ROOM-12 CANYON

No.	Parameter	Range	Value	MIDI Parameter Number	Table
1	Reverb Time	0.3s-30.0s	(0-69)	1	4
2	Initial Delay	0.1ms-200.0ms	(0-127)	3	5
3	Reverb Delay	0.1ms-200.0ms	(0-127)	10	5
4	HPF Cutoff Frequency	20Hz-8.0kHz	(0-52)	4	3
5	LPF Cutoff Frequency	1.0kHz-20.0kHz	(34-60)	5	3
6	Diffusion	0-10	(0-10)	2	
7	Width	0.5m-30.2m	(0-104)	6	11
8	Height	0.5m-30.2m	(0-104)	7	11
9	Depth	0.5m-30.2m	(0-104)	8	11
10	Wall Vary	0-30	(0-30)	9	

## 2. Chorus

### 01 CHORUS 1-09 CELESTE 4

No.	Parameter	Range	Value	MIDI Parameter Number	Table
1	LFO Speed	0.0Hz-39.70Hz	(0-127)	1	1
2	LFO Depth	0-127	(0-127)	2	
3	EQ Low Frequency	32Hz-2.0kHz	(4-40)	5	3
4	EQ Low Gain	-12dB-+12dB	(52-76)	6	
5	EQ High Frequency	500Hz-16.0kHz	(28-58)	7	3
6	EQ High Gain	-12dB-+12dB	(52-76)	8	
7	Delay Offset	0.0ms-50.0ms	(0-127)	4	2
8	Feedback Level	-63-+63	(1-127)	3	

### 10 SYMPHONIC

No.	Parameter	Range	Value	MIDI Parameter Number	Table
1	LFO Speed	0.0Hz-39.70Hz	(0-127)	1	1
2	LFO Depth	0-127	(0-127)	2	
3	Delay Offset	0.0ms-50.0ms	(0-127)	3	2
4	EQ Low Frequency	32Hz-2.0kHz	(4-40)	4	3
5	EQ Low Gain	-12dB-+12dB	(52-76)	5	
6	EQ High Frequency	500Hz-16.0kHz	(28-58)	6	3
7	EQ High Gain	-12dB-+12dB	(52-76)	7	

### 11 ENSEMBLE DETUNE

No.	Parameter	Range	Value	MIDI Parameter Number	Table
1	Detune	-50cent-+50cent	(14-114)	1	
2	Initial Delay Lch	0.0ms-50.0ms	(0-127)	2	2
3	Initial Delay Rch	0.0ms-50.0ms	(0-127)	3	2

### 12 FLANGER 1-14 FLANGER 3

No.	Parameter	Range	Value	MIDI Parameter Number	Table
1	LFO Speed	0.0Hz-39.70Hz	(0-127)	1	1
2	LFO Depth	0-127	(0-127)	2	
3	LFO Phase Difference	-180deg-+180deg	(4-124)	5	
4	EQ Low Frequency	32Hz-2.0kHz	(4-40)	6	3
5	EQ Low Gain	-12dB-+12dB	(52-76)	7	
6	EQ High Frequency	500Hz-16.0kHz	(28-58)	8	3
7	EQ High Gain	-12dB-+12dB	(52-76)	9	
8	Delay Offset	0.0ms-50.0ms	(0-127)	4	2
9	Feedback Level	-63-+63	(1-127)	3	

### 15 TEMPO FLANGER

No.	Parameter	Range	Value	MIDI Parameter Number	Table
1	LFO Speed	16th, 8th/3, 16th., 8th, 4th/3, 8th., 4th, 2nd/3, 4th., 2nd, Whole/3, 2nd., 4thx4, 4thx5, 4thx6, 4thx7, 4thx8	(5-21)	1	
2	LFO Depth	0-127	(0-127)	2	
3	LFO Phase Difference	-180deg-+180deg	(0-2)	5	
4	LFO Phase Reset	off(free run), Key On Reset, SEQ Start Reset	(4-124)	6	
5	EQ Low Frequency	32Hz-2.0kHz	(4-40)	7	3
6	EQ Low Gain	-12dB-+12dB	(52-76)	8	
7	EQ High Frequency	500Hz-16.0kHz	(28-58)	9	3
8	EQ High Gain	-12dB-+12dB	(52-76)	10	
9	Delay Offset	0.0ms-50.0ms	(0-127)	4	2
10	Feedback Level	-63-+63	(1-127)	3	

### 16 PHASER 1

No.	Parameter	Range	Value	MIDI Parameter Number	Table
1	LFO Speed	0.0Hz-39.70Hz	(0-127)	1	1
2	LFO Depth	0-127	(0-127)	2	
3	Diffusion	mono/stereo	(0-1)	6	
4	EQ Low Frequency	32Hz-2.0kHz	(4-40)	7	3
5	EQ Low Gain	-12dB-+12dB	(52-76)	8	
6	EQ High Frequency	500Hz-16.0kHz	(28-58)	9	3
7	EQ High Gain	-12dB-+12dB	(52-76)	10	
8	Stage	4, 5, 6	(4-6)	5	
9	Phase Shift Offset	0-127	(0-127)	3	
10	Feedback Level	-63-+63	(1-127)	4	

### 17 TEMPO PHASER

No.	Parameter	Range	Value	MIDI Parameter Number	Table
1	LFO Speed	16th, 8th/3, 16th., 8th, 4th/3, 8th., 4th, 2nd/3, 4th., 2nd, Whole/3, 2nd., 4thx4, 4thx5, 4thx6, 4thx7, 4thx8	(5-21)	1	
2	LFO Depth	0-127	(0-127)	2	
3	LFO Phase Reset	off(free run), Key On Reset, SEQ Start Reset	(0-2)	6	
4	EQ Low Frequency	32Hz-2.0kHz	(4-40)	7	3
5	EQ Low Gain	-12dB-+12dB	(52-76)	8	
6	EQ High Frequency	500Hz-16.0kHz	(28-58)	9	3
7	EQ High Gain	-12dB-+12dB	(52-76)	10	
8	Stage	4, 5, 6	(4-6)	5	
9	Phase Shift Offset	0-127	(0-127)	3	
10	Feedback Level	-63-+63	(1-127)	4	

### 18 DELAY L, R

No.	Parameter	Range	Value	MIDI Parameter Number	Table
1	Lch Delay Time	0.1ms-740.0ms	(0-127)	1	19
2	Rch Delay Time	0.1ms-740.0ms	(0-127)	2	19
3	Lch Feedback Time	0.1ms-740.0ms	(0-127)	3	19
4	Rch Feedback Time	0.1ms-740.0ms	(0-127)	4	19
5	Feedback Level	-63-+63	(1-127)	5	
6	Feedback High Damp	0.1-1.0	(1-10)	6	
7	EQ Low Frequency	32Hz-2.0kHz	(4-40)	7	3
8	EQ Low Gain	-12dB-+12dB	(52-76)	8	
9	EQ High Frequency	500Hz-16.0kHz	(28-58)	9	3
10	EQ High Gain	-12dB-+12dB	(52-76)	10	

### 19 ECHO

No.	Parameter	Range	Value	MIDI Parameter Number	Table
1	Lch Delay1 Time	0.1ms-740.0ms	(0-127)	1	19
2	Rch Delay1 Time	0.1ms-740.0ms	(0-127)	3	19
3	Lch Feedback Level	-63-+63	(1-127)	2	
4	Rch Feedback Level	-63-+63	(1-127)	4	
5	Feedback High Damp	0.1-1.0	(1-10)	5	
6	EQ Low Frequency	32Hz-2.0kHz	(4-40)	6	3
7	EQ Low Gain	-12dB-+12dB	(52-76)	7	
8	EQ High Frequency	500Hz-16.0kHz	(28-58)	8	3
9	EQ High Gain	-12dB-+12dB	(52-76)	9	

## 20 CROSS DELAY

No.	Parameter	Range	Value	MIDI Parameter Number	Table
1	L →R Delay Time	0.1ms~740.0ms	(0~127)	1	19
2	R →L Delay Time	0.1ms~740.0ms	(0~127)	2	19
3	Input Select	L, R, L&R	(0~2)	4	
4	Feedback Level	-63~+63	(1~127)	3	
5	Feedback High Damp	0.1~1.0	(1~10)	5	
6	EQ Low Frequency	32Hz~2.0kHz	(4~40)	6	3
7	EQ Low Gain	-12dB~+12dB	(52~76)	7	
8	EQ High Frequency	500Hz~16.0kHz	(28~58)	8	3
9	EQ High Gain	-12dB~+12dB	(52~76)	9	

## 21 CONTROL DELAY(MONO)

No.	Parameter	Range	Value	MIDI Parameter Number	Table
1	Delay Time	0.1ms~1480.0ms	(0~127)	1	20
2	Delay Transition Rate	1~48	(1~48)	2	
3	Feedback Level	-63~+63	(1~127)	3	
4	Feedback High Damp	0.1~1.0	(1~10)	4	
5	Delay Time Offset	0~127	(0~127)	5	
6	Control Type	normal, scratch	(0~1)	6	
7	EQ Low Frequency	32Hz~2.0kHz	(4~40)	7	3
8	EQ Low Gain	-12dB~+12dB	(52~76)	8	
9	EQ High Frequency	500Hz~16.0kHz	(28~58)	9	3
10	EQ High Gain	-12dB~+12dB	(52~76)	10	

## 22 CONTROL DELAY(STEREO)

No.	Parameter	Range	Value	MIDI Parameter Number	Table
1	Delay Time	0.1ms~740.0ms	(0~127)	1	19
2	Delay Transition Rate	1~48	(1~48)	2	
3	Feedback Level	-63~+63	(1~127)	3	
4	Feedback High Damp	0.1~1.0	(1~10)	4	
5	Delay Time Offset	0~127	(0~127)	5	
6	Control Type	normal, scratch	(0~1)	6	
7	EQ Low Frequency	32Hz~2.0kHz	(4~40)	7	3
8	EQ Low Gain	-12dB~+12dB	(52~76)	8	
9	EQ High Frequency	500Hz~16.0kHz	(28~58)	9	3
10	EQ High Gain	-12dB~+12dB	(52~76)	10	

## 23 TEMPO DELAY (MONO)--24 TEMPO DELAY (STEREO)

No.	Parameter	Range	Value	MIDI Parameter Number	Table
1	Delay Time	32nd, 16th/3, 32nd., 16th, 8th/3, 16th., 8th, 4th/3, 8th., 4th, 2nd/3, 4th., 2nd	(2~14)	1	
2	Lag	-63ms~+63ms	(1~127)	5	
3	L/R Diffusion	-63ms~+63ms	(1~127)	4	
4	Feedback Level	-63~+63	(1~127)	2	
5	Feedback High Dump	0.1~1.0	(1~10)	3	
6	EQ Low Frequency	32Hz~2.0kHz	(4~40)	6	3
7	EQ Low Gain	-12dB~+12dB	(52~76)	7	
8	EQ High Frequency	500Hz~16.0kHz	(28~58)	8	3
9	EQ High Gain	-12dB~+12dB	(52~76)	9	

## 25 TEMPO CROSS DELAY

No.	Parameter	Range	Value	MIDI Parameter Number	Table
1	L →R Delay Time	32nd, 16th/3, 32nd., 16th, 8th/3, 16th., 8th, 4th/3, 8th., 4th, 2nd/3, 4th., 2nd	(2~14)	1	
2	R →L Delay Time	32nd, 16th/3, 32nd., 16th, 8th/3, 16th., 8th, 4th/3, 8th., 4th, 2nd/3, 4th., 2nd	(2~14)	2	
3	Input Select	L, R, L&R	(0~2)	5	
4	Lag	-63ms~+63ms	(1~127)	6	
5	Feedback Level	-63~+63	(1~127)	3	
6	Feedback High Dump	0.1~1.0	(1~10)	4	
7	EQ Low Frequency	32Hz~2.0kHz	(4~40)	7	3
8	EQ Low Gain	-12dB~+12dB	(52~76)	8	
9	EQ High Frequency	500Hz~16.0kHz	(28~58)	9	3
10	EQ High Gain	-12dB~+12dB	(52~76)	10	

## 3. Insertion Effect 2

### 001 HALL1-008 PLATE

No.	Parameter	Range	Value	MIDI Parameter Number	Table
1	Reverb Time	0.3s~30.0s	(0~69)	1	4
2	Initial Delay	0.1ms~99.3ms	(0~63)	3	5
3	Reverb Delay	0.1ms~99.3ms	(0~63)	11	5
4	Dry/Wet Balance	D63>W=D=W-D<W63	(1~127)	10	
5	HPF Cutoff Frequency	20Hz~8.0kHz	(0~52)	4	3
6	LPF Cutoff Frequency	1.0kHz~20.0kHz	(34~60)	5	3
7	Diffusion	0~10	(0~10)	2	
8	Density	0~4	(0~4)	12	
9	ER/Rev Balance	E63>R=E=R-E<R63	(1~127)	13	
10	Feedback Level	-63~+63	(1~127)	15	
11	Feedback High Damp	0.1~1.0	(1~10)	14	

### 009 DELAY L, C, R

No.	Parameter	Range	Value	MIDI Parameter Number	Table
1	Lch Delay Time	0.1ms~1486.0ms	(1~14860)	1	
2	Rch Delay Time	0.1ms~1486.0ms	(1~14860)	2	
3	Cch Delay Time	0.1ms~1486.0ms	(1~14860)	3	
4	Dry/Wet Balance	D63>W=D=W-D<W63	(1~127)	10	
5	Cch Level	0~127	(0~127)	6	
6	Feedback Time	0.1ms~1486.0ms	(1~14860)	4	
7	Feedback Level	-63~+63	(1~127)	5	
8	Feedback High Damp	0.1~1.0	(1~10)	7	
9	EQ Low Frequency	32Hz~2.0kHz	(4~40)	13	3
10	EQ Low Gain	-12dB~+12dB	(52~76)	14	
11	EQ High Frequency	500Hz~16.0kHz	(28~58)	15	3
12	EQ High Gain	-12dB~+12dB	(52~76)	16	

### 010 DELAY L, R

No.	Parameter	Range	Value	MIDI Parameter Number	Table
1	Lch Delay Time	0.1ms~1486.0ms	(1~14860)	1	
2	Rch Delay Time	0.1ms~1486.0ms	(1~14860)	2	
3	Dry/Wet Balance	D63>W=D=W-D<W63	(1~127)	10	
4	Lch Feedback Time	0.1ms~1486.0ms	(1~14860)	3	
5	Rch Feedback Time	0.1ms~1486.0ms	(1~14860)	4	
6	Feedback Level	-63~+63	(1~127)	5	
7	Feedback High Damp	0.1~1.0	(1~10)	6	
8	EQ Low Frequency	32Hz~2.0kHz	(4~40)	13	3
9	EQ Low Gain	-12dB~+12dB	(52~76)	14	
10	EQ High Frequency	500Hz~16.0kHz	(28~58)	15	3
11	EQ High Gain	-12dB~+12dB	(52~76)	16	

### 011 ECHO

No.	Parameter	Range	Value	MIDI Parameter Number	Table
1	Lch Delay1 Time	0.1ms~743.0ms	(1~7430)	1	
2	Rch Delay1 Time	0.1ms~743.0ms	(1~7430)	3	
3	Dry/Wet Balance	D63>W=D=W-D<W63	(1~127)	10	
4	Lch Feedback Level	-63~+63	(1~127)	2	
5	Rch Feedback Level	-63~+63	(1~127)	4	
6	Feedback High Damp	0.1~1.0	(1~10)	5	
7	Lch Delay2 Time	0.1ms~743.0ms	(1~7430)	6	
8	Rch Delay2 Time	0.1ms~743.0ms	(1~7430)	7	
9	Delay2 Level	0~127	(0~127)	8	
10	EQ Low Frequency	32Hz~2.0kHz	(4~40)	13	3
11	EQ Low Gain	-12dB~+12dB	(52~76)	14	
12	EQ High Frequency	500Hz~16.0kHz	(28~58)	15	3
13	EQ High Gain	-12dB~+12dB	(52~76)	16	

### 012 CROSS DELAY

No.	Parameter	Range	Value	MIDI Parameter Number	Table
1	L →R Delay Time	0.1ms~743.0ms	(1~7430)	1	
2	R →L Delay Time	0.1ms~743.0ms	(1~7430)	2	
3	Input Select	L, R, L&R	(0~2)	4	
4	Dry/Wet Balance	D63>W=D=W-D<W63	(1~127)	10	
5	Feedback Level	-63~+63	(1~127)	3	
6	Feedback High Damp	0.1~1.0	(1~10)	5	
7	EQ Low Frequency	32Hz~2.0kHz	(4~40)	13	3
8	EQ Low Gain	-12dB~+12dB	(52~76)	14	
9	EQ High Frequency	500Hz~16.0kHz	(28~58)	15	3
10	EQ High Gain	-12dB~+12dB	(52~76)	16	

**013 CONTROL DELAY(MONO)**

No.	Parameter	Range	Value	MIDI Parameter Number	Table
1	Delay Time	0.1ms-1486.0ms	(1-14860 )	1	
2	Delay Transition Rate	1-48	(1-48)	2	
3	Dry/Wet Balance	D63>W-D=W-D<W63	(1-127)	10	
4	Control Type	normal, scratch	(0-1)	11	
5	Feedback Level	-63~+63	(1-127)	3	
6	Feedback High Damp	0.1-1.0	(1-10)	4	
7	EQ Low Frequency	32Hz-2.0kHz	(4-40)	6	3
8	EQ Low Gain	-12dB~+12dB	(52-76)	7	
9	EQ High Frequency	500Hz-16.0kHz	(28-58)	8	3
10	EQ High Gain	-12dB~+12dB	(52-76)	9	

**014 CONTROL DELAY (STEREO)**

No.	Parameter	Range	Value	MIDI Parameter Number	Table
1	Delay Time	0.1ms-743.0ms	(1-7430 )	1	
2	Delay Transition Rate	1-48	(1-48)	2	
3	Dry/Wet Balance	D63>W-D=W-D<W63	(1-127)	10	
4	Control Type	normal, scratch	(0-1)	11	
5	Feedback Level	-63~+63	(1-127)	3	
6	Feedback High Damp	0.1-1.0	(1-10)	4	
7	EQ Low Frequency	32Hz-2.0kHz	(4-40)	6	3
8	EQ Low Gain	-12dB~+12dB	(52-76)	7	
9	EQ High Frequency	500Hz-16.0kHz	(28-58)	8	3
10	EQ High Gain	-12dB~+12dB	(52-76)	9	

**015 TEMPO DELAY (MONO)-016 TEMPO DELAY (STEREO)**

No.	Parameter	Range	Value	MIDI Parameter Number	Table
1	Delay Time	32nd, 16th/3, 32nd., 16th, 8th/3, 16th., 8th, 4th/3, 8th., 4th, 2nd/3, 4th., 2nd	(2-14)	1	
2	Dry/Wet Balance	D63>W-D=W-D<W63	(1-127)	10	
3	Lag	-63ms~+63ms	(1-127)	6	
4	L/R Diffusion	-63ms~+63ms	(1-127)	5	
5	Feedback Level	-63~+63	(1-127)	3	
6	Feedback High Dump	0.1-1.0	(1-10)	4	
7	EQ Low Frequency	32Hz-2.0kHz	(4-40)	13	3
8	EQ Low Gain	-12dB~+12dB	(52-76)	14	
9	EQ High Frequency	500Hz-16.0kHz	(28-58)	15	3
10	EQ High Gain	-12dB~+12dB	(52-76)	16	

**017 TEMPO CROSS DELAY**

No.	Parameter	Range	Value	MIDI Parameter Number	Table
1	L->R Delay Time	32nd, 16th/3, 32nd., 16th, 8th/3, 16th., 8th, 4th/3, 8th., 4th, 2nd/3, 4th., 2nd	(2-14)	1	
2	R->L Delay Time	32nd, 16th/3, 32nd., 16th, 8th/3, 16th., 8th, 4th/3, 8th., 4th, 2nd/3, 4th., 2nd	(2-14)	2	
3	Input Select	L, R, L&R	(0-2)	6	
4	Dry/Wet Balance	D63>W-D=W-D<W63	(1-127)	10	
5	Lag	-63ms~+63ms	(1-127)	8	
6	Feedback Level	-63~+63	(1-127)	4	
7	Feedback High Dump	0.1-1.0	(1-10)	5	
8	EQ Low Frequency	32Hz-2.0kHz	(4-40)	13	3
9	EQ Low Gain	-12dB~+12dB	(52-76)	14	
10	EQ High Frequency	500Hz-16.0kHz	(28-58)	15	3
11	EQ High Gain	-12dB~+12dB	(52-76)	16	

**018 EARLY REFLECTION 1-019 EARLY REFLECTION 2**

No.	Parameter	Range	Value	MIDI Parameter Number	Table
1	Type	S-hall, L-hall, random, reverse, plate, spring	(0-5)	1	
2	Room Size	0.1-20.0	(0-127)	2	6
3	Dry/Wet Balance	D63>W-D=W-D<W63	(1-127)	10	
4	Diffusion	0-10	(0-10)	3	
5	Initial Delay	0.1ms-200.0ms	(0-127)	4	5
6	Liveness	0-10	(0-10)	11	
7	Density	0-3	(0-3)	12	
8	HPF Cutoff Frequency	20Hz-8.0kHz	(0-52)	6	3
9	LPF Cutoff Frequency	1.0kHz-20.0kHz	(34-60)	7	3
10	Feedback Level	-63~+63	(1-127)	5	
11	Feedback High Damp	0.1-1.0	(1-10)	13	

**020 GATE REVERB-021 REVERSE GATE**

No.	Parameter	Range	Value	MIDI Parameter Number	Table
1	Type	type-A, type-B	(0-1)	1	
2	Room Size	0.1-20.0	(0-127)	2	6
3	Dry/Wet Balance	D63>W-D=W-D<W63	(1-127)	10	
4	Diffusion	0-10	(0-10)	3	
5	Initial Delay	0.1ms-200.0ms	(0-127)	4	5
6	Liveness	0-10	(0-10)	11	
7	Density	0-3	(0-3)	12	
8	HPF Cutoff Frequency	20Hz-8.0kHz	(0-52)	6	3
9	LPF Cutoff Frequency	1.0kHz-20.0kHz	(34-60)	7	3
10	Feedback Level	-63~+63	(1-127)	5	
11	Feedback High Damp	0.1-1.0	(1-10)	13	

**022 KARAOKE 1-024 KARAOKE 3**

No.	Parameter	Range	Value	MIDI Parameter Number	Table
1	Delay Time	0.1ms-400.0ms	(0-127 )	1	7
2	Feedback Level	-63~+63	(1-127)	2	
3	Dry/Wet Balance	D63>W-D=W-D<W63	(1-127)	10	
4	HPF Cutoff Frequency	20Hz-8.0kHz	(0-52)	3	3
5	LPF Cutoff Frequency	1.0kHz-20.0kHz	(34-60)	4	3

**025 CHORUS 1-033 CELESTE 4**

No.	Parameter	Range	Value	MIDI Parameter Number	Table
1	LFO Speed	0.0Hz-39.70Hz	(0-127)	1	1
2	LFO Depth	0-127	(0-127)	2	
3	Input Mode	mono/stereo	(0-1)	15	
4	EQ Low Frequency	32Hz-2.0kHz	(4-40)	6	3
5	EQ Low Gain	-12dB~+12dB	(52-76)	7	
6	EQ High Frequency	500Hz-16.0kHz	(28-58)	8	3
7	EQ High Gain	-12dB~+12dB	(52-76)	9	
8	EQ Mid Frequency	100Hz-10.0kHz	(14-54)	11	3
9	EQ Mid Gain	-12dB~+12dB	(52-76)	12	
10	EQ Mid Width	0.1-12.0	(1-120)	13	
11	Delay Offset	0.0ms-50.0ms	(0-127)	4	2
12	Feedback Level	-63~+63	(1-127)	3	
13	Dry/Wet Balance	D63>W-D=W-D<W63	(1-127)	10	

**034 SYMPHONIC**

No.	Parameter	Range	Value	MIDI Parameter Number	Table
1	LFO Speed	0.0Hz-39.70Hz	(0-127)	1	1
2	LFO Depth	0-127	(0-127)	2	
3	Delay Offset	0.0ms-50.0ms	(0-127)	4	2
4	EQ Low Frequency	32Hz-2.0kHz	(4-40)	6	3
5	EQ Low Gain	-12dB~+12dB	(52-76)	7	
6	EQ High Frequency	500Hz-16.0kHz	(28-58)	8	3
7	EQ High Gain	-12dB~+12dB	(52-76)	9	
8	EQ Mid Frequency	100Hz-10.0kHz	(14-54)	11	3
9	EQ Mid Gain	-12dB~+12dB	(52-76)	12	
10	EQ Mid Width	0.1-12.0	(1-120)	13	
11	Dry/Wet Balance	D63>W-D=W-D<W63	(1-127)	10	

**035 ENSEMBLE DETUNE**

No.	Parameter	Range	Value	MIDI Parameter Number	Table
1	Detune	-50cent~+50cent	(14-114)	1	
2	Lch Initial Delay	0.0ms-50.0ms	(0-127)	2	2
3	Rch Initial Delay	0.0ms-50.0ms	(0-127)	3	2
4	Dry/Wet Balance	D63>W-D=W-D<W63	(1-127)	10	
5	EQ Low Frequency	32Hz-2.0kHz	(4-40)	11	3
6	EQ Low Gain	-12dB~+12dB	(52-76)	12	
7	EQ High Frequency	500Hz-16.0kHz	(28-58)	13	3
8	EQ High Gain	-12dB~+12dB	(52-76)	14	



**036 FLANGER 1-038 FLANGER 3**

No.	Parameter	Range	Value	MIDI Parameter Number	Table
1	LFO Speed	0.0Hz-39.70Hz	(0-127)	1	1
2	LFO Depth	0-127	(0-127)	2	
3	LFO Phase Difference	-180deg--+180deg	(4-124)	14	
4	EQ Low Frequency	32Hz-2.0kHz	(4-40)	6	3
5	EQ Low Gain	-12dB--+12dB	(52-76)	7	
6	EQ High Frequency	500Hz-16.0kHz	(28-58)	8	3
7	EQ High Gain	-12dB--+12dB	(52-76)	9	
8	EQ Mid Frequency	100Hz-10.0kHz	(14-54)	11	3
9	EQ Mid Gain	-12dB--+12dB	(52-76)	12	
10	EQ Mid Width	0.1-12.0	(1-120)	13	
11	Delay Offset	0.0ms-50.0ms	(0-127)	4	2
12	Feedback Level	-63--+63	(1-127)	3	
13	Dry/Wet Balance	D63>W-D=W-D<W63	(1-127)	10	

**039 V-FLANGER**

No.	Parameter	Range	Value	MIDI Parameter Number	Table
1	LFO Speed	0.0Hz-39.70Hz	(0-127)	1	1
2	LFO Depth	0-127	(0-127)	2	
3	LFO Wave	Triangle, Sine, Random	(0-2)	3	
4	Modulation Phase	-180--+180	(0-16)	5	
5	EQ Low Frequency	32Hz-2.0kHz	(4-40)	6	3
6	EQ Low Gain	-12dB--+12dB	(52-76)	7	
7	EQ High Frequency	500Hz-16.0kHz	(28-58)	8	3
8	EQ High Gain	-12dB--+12dB	(52-76)	9	
9	EQ Mid Frequency	100Hz-10.0kHz	(14-54)	11	3
10	EQ Mid Gain	-12dB--+12dB	(52-76)	12	
11	EQ Mid Width	0.1-12.0	(1-120)	13	
12	Analog Feel	0-10	(0-10)	16	
13	Feedback Level	-100--+100%	(0-200)	14	
14	Feedback High Damp	0.1-1.0	(1-10)	15	
15	Delay offset	0.09-36.21ms	(0-139)	4	
16	Dry/Wet Balance	D63>W-D=W-D<W63	(1-127)	10	

**040 TEMPO FLANGER**

No.	Parameter	Range	Value	MIDI Parameter Number	Table
1	LFO Speed	16th, 8th/3, 16th., 8th, 4th/3, 8th., 4th, 2nd/3, 4th., 2nd, Whole/3, 2nd., 4thx4, 4thx5, 4thx6, 4thx7, 4thx8	(5-21)	1	
2	LFO Depth	0-127	(0-127)	2	
3	LFO Phase Difference	-180deg--+180deg	(4-124)	14	
4	LFO Phase Reset	off(free run), Key On Reset, SEQ Start Reset	(0-2)	5	
5	EQ Low Frequency	32Hz-2.0kHz	(4-40)	6	3
6	EQ Low Gain	-12dB--+12dB	(52-76)	7	
7	EQ High Frequency	500Hz-16.0kHz	(28-58)	8	3
8	EQ High Gain	-12dB--+12dB	(52-76)	9	
9	EQ Mid Frequency	100Hz-10.0kHz	(14-54)	11	3
10	EQ Mid Gain	-12dB--+12dB	(52-76)	12	
11	EQ Mid Width	0.1-12.0	(1-120)	13	
12	Delay offset	0.0ms-50.0ms	(0-127)	4	2
13	Feedback Level	-63--+63	(1-127)	3	
14	Dry/Wet Balance	D63>W-D=W-D<W63	(1-127)	10	

**41 DYNAMIC FLANGER**

No.	Parameter	Range	Value	MIDI Parameter Number	Table
1	Sensitivity	0-127	(0-127)	1	
2	Delay Time Offset	0-127	(0-127)	2	
3	Feedback Level	-63--+63	(1-127)	3	
4	Attack Time	0.3ms-227ms	(0-127)	4	17
5	Release Time	2.6ms-2171ms	(0-127)	5	18
6	Release Curve	0-127	(0-127)	6	
7	Direction	up, down	(0-1)	7	
8	Dyna Threshold Level	0-127	(0-127)	8	
9	Dyna Level Offset	0-127	(0-127)	9	
10	Dry/Wet Balance	D63>W-D=W-D<W63	(1-127)	10	
11	EQ Low Frequency	32Hz-2.0kHz	(4-40)	13	3
12	EQ Low Gain	-12dB--+12dB	(52-76)	14	
13	EQ High Frequency	500Hz-16.0kHz	(28-58)	15	3
14	EQ High Gain	-12dB--+12dB	(52-76)	16	

**42 PHASER 1**

No.	Parameter	Range	Value	MIDI Parameter Number	Table
1	LFO Speed	0.0Hz-39.70Hz	(0-127)	1	1
2	LFO Depth	0-127	(0-127)	2	
3	Diffusion	mono/stereo	(0-1)	12	
4	EQ Low Frequency	32Hz-2.0kHz	(4-40)	6	3
5	EQ Low Gain	-12dB--+12dB	(52-76)	7	
6	EQ High Frequency	500Hz-16.0kHz	(28-58)	8	3
7	EQ High Gain	-12dB--+12dB	(52-76)	9	
8	Stage	4, 5, 6, 7, 8, 9, 10, 11, 12	(4-12)	11	
9	Phase Shift Offset	0-127	(0-127)	3	
10	Feedback Level	-63--+63	(1-127)	4	
11	Dry/Wet Balance	D63>W-D=W-D<W63	(1-127)	10	

**043 PHASER 2**

No.	Parameter	Range	Value	MIDI Parameter Number	Table
1	LFO Speed	0.0Hz-39.70Hz	(0-127)	1	1
2	LFO Depth	0-127	(0-127)	2	
3	LFO Phase Difference	-180deg--+180deg	(4-124)	13	
4	EQ Low Frequency	32Hz-2.0kHz	(4-40)	6	3
5	EQ Low Gain	-12dB--+12dB	(52-76)	7	
6	EQ High Frequency	500Hz-16.0kHz	(28-58)	8	3
7	EQ High Gain	-12dB--+12dB	(52-76)	9	
8	Stage	3, 4, 5, 6	(3-6)	11	
9	Phase Shift Offset	0-127	(0-127)	3	
10	Feedback Level	-63--+63	(1-127)	4	
11	Dry/Wet Balance	D63>W-D=W-D<W63	(1-127)	10	

**44 TEMPO PHASER**

No.	Parameter	Range	Value	MIDI Parameter Number	Table
1	LFO Speed	16th, 8th/3, 16th., 8th, 4th/3, 8th., 4th, 2nd/3, 4th., 2nd, Whole/3, 2nd., 4thx4, 4thx5, 4thx6, 4thx7, 4thx8	(5-21)	1	
2	LFO Depth	0-127	(0-127)	2	
4	LFO Phase Reset	off(free run), Key On Reset, SEQ Start Reset	(0-2)	5	
3	LFO Phase Difference (deg)	-180deg--+180deg	(4-124)	13	
5	EQ Low Frequency	32Hz-2.0kHz	(4-40)	6	3
6	EQ Low Gain	-12dB--+12dB	(52-76)	7	
7	EQ High Frequency	500Hz-16.0kHz	(28-58)	8	3
8	EQ High Gain	-12dB--+12dB	(52-76)	9	
9	Stage	3, 4, 5, 6	(3-6)	11	
10	Phase Shift Offset	0-127	(0-127)	3	
11	Feedback Level	-63--+63	(1-127)	4	
12	Dry/Wet Balance	D63>W-D=W-D<W63	(1-127)	10	

**045 DYNAMIC PHASER**

No.	Parameter	Range	Value	MIDI Parameter Number	Table
1	Sensitivity	0-127	(0-127)	1	
2	Dyna Level Offset	0-127	(0-127)	2	
3	Feedback Level	-63--+63	(1-127)	3	
4	Attack Time	0.3ms-227ms	(0-127)	4	17
5	Release Time	2.6ms-2171ms	(0-127)	5	18
6	Release Curve	0-127	(0-127)	6	
7	Direction	up, down	(0-1)	7	
8	Dyna Threshold Level	0-127	(0-127)	8	
9	Dry/Wet Balance	D63>W-D=W-D<W63	(1-127)	10	
10	Stage	4, 5, 6	(4-6)	11	
11	EQ Low Frequency	32Hz-2.0kHz	(4-40)	13	3
12	EQ Low Gain	-12dB--+12dB	(52-76)	14	
13	EQ High Frequency	500Hz-16.0kHz	(28-58)	15	3
14	EQ High Gain	-12dB--+12dB	(52-76)	16	

**046 TREMOLO**

No.	Parameter	Range	Value	MIDI Parameter Number	Table
1	LFO Speed	0.0Hz-39.70Hz	(0-127)	1	1
2	AM Depth	0-127	(0-127)	2	
3	PM Depth	0-127	(0-127)	3	
4	LFO Phase Difference	-180deg-+180deg	(4-124)	14	
5	EQ Low Frequency	32Hz-2.0kHz	(4-40)	6	3
6	EQ Low Gain	-12dB-+12dB	(52-76)	7	
7	EQ High Frequency	500Hz-16.0kHz	(28-58)	8	3
8	EQ High Gain	-12dB-+12dB	(52-76)	9	
9	EQ Mid Frequency	100Hz-10.0kHz	(14-54)	11	3
10	EQ Mid Gain	-12dB-+12dB	(52-76)	12	
11	EQ Mid Width	0.1-12.0	(1-120)	13	
12	Input Mode	mono/stereo	(0-1)	15	

**047 AUTO PAN**

No.	Parameter	Range	Value	MIDI Parameter Number	Table
1	LFO Speed	0.0Hz-39.70Hz	(0-127)	1	1
2	L/R Depth	0-127	(0-127)	2	
3	F/R Depth	0-127	(0-127)	3	
4	PAN Direction	L<>R, L>>R, L<<R, Lturn, Rturn, L/R	(0-5)	4	
5	EQ Low Frequency	32Hz-2.0kHz	(4-40)	6	3
6	EQ Low Gain	-12dB-+12dB	(52-76)	7	
7	EQ High Frequency	500Hz-16.0kHz	(28-58)	8	3
8	EQ High Gain	-12dB-+12dB	(52-76)	9	
9	EQ Mid Frequency	100Hz-10.0kHz	(14-54)	11	3
10	EQ Mid Gain	-12dB-+12dB	(52-76)	12	
11	EQ Mid Width	0.1-12.0	(1-120)	13	

**048 AUTO PAN 2**

No.	Parameter	Range	Value	MIDI Parameter Number	Table
1	LFO Speed	0.0Hz-39.70Hz	(0-127)	1	1
2	LFO Wave	0-28	(0-28)	2	
3	L/R Depth	0-127	(0-127)	3	
4	F/R Depth	0-127	(0-127)	4	
5	EQ Low Frequency	32Hz-2.0kHz	(4-40)	6	3
6	EQ Low Gain	-12dB-+12dB	(52-76)	7	
7	EQ High Frequency	500Hz-16.0kHz	(28-58)	8	3
8	EQ High Gain	-12dB-+12dB	(52-76)	9	
9	PAN Direction	L<>R, L>>R, L<<R, Lturn, Rturn, L/R	(0-5)	5	
10	EQ Mid Frequency	100Hz-10.0kHz	(14-54)	11	3
11	EQ Mid Gain	-12dB-+12dB	(52-76)	12	
12	EQ Mid Width	0.1-12.0	(1-120)	13	

**049 ROTARY SPEAKER**

No.	Parameter	Range	Value	MIDI Parameter Number	Table
1	LFO Speed	0.0Hz-39.70Hz	(0-127)	1	1
2	LFO Depth	0-127	(0-127)	2	
3	EQ Low Frequency	32Hz-2.0kHz	(4-40)	6	3
4	EQ Low Gain	-12dB-+12dB	(52-76)	7	
5	EQ High Frequency	500Hz-16.0kHz	(28-58)	8	3
6	EQ High Gain	-12dB-+12dB	(52-76)	9	
7	EQ Mid Frequency	100Hz-10.0kHz	(14-54)	11	3
8	EQ Mid Gain	-12dB-+12dB	(52-76)	12	
9	EQ Mid Width	0.1-12.0	(1-120)	13	
10	Dry/Wet Balance	D63>W=D=W<D<W63	(1-127)	10	

**050 DISTORTION + ROTARY SPEAKER-051 OVERDRIVE + ROTARY SPEAKER**

No.	Parameter	Range	Value	MIDI Parameter Number	Table
1	LFO Speed	0.0Hz-39.70Hz	(0-127)	1	1
2	LFO Depth	0-127	(0-127)	2	
3	Drive	0-127	(0-127)	14	
4	Drive LPF Cutoff Freq	1.0kHz-20.0kHz	(34-60)	15	3
5	Drive Output Level	0-127	(0-127)	16	
6	EQ Low Frequency	32Hz-2.0kHz	(4-40)	6	3
7	EQ Low Gain	-12dB-+12dB	(52-76)	7	
8	EQ High Frequency	500Hz-16.0kHz	(28-58)	8	3
9	EQ High Gain	-12dB-+12dB	(52-76)	9	

**052 AMP SIM. + ROTARY SPEAKER**

No.	Parameter	Range	Value	MIDI Parameter Number	Table
1	LFO Speed	0.0Hz-39.70Hz	(0-127)	1	1
2	LFO Depth	0-127	(0-127)	2	
3	Amp Type	off, stack, combo, tube	(0-3)	3	
4	Amp Drive	0-127	(0-127)	14	
5	Amp LPF Cutoff Freq	1.0kHz-20.0kHz	(34-60)	15	3
6	Amp Output Level	0-127	(0-127)	16	
7	EQ Low Frequency	32Hz-2.0kHz	(4-40)	6	3
8	EQ Low Gain	-12dB-+12dB	(52-76)	7	
9	EQ High Frequency	500Hz-16.0kHz	(28-58)	8	3
10	EQ High Gain	-12dB-+12dB	(52-76)	9	

**053 2-WAY ROTARY SPEAKER**

No.	Parameter	Range	Value	MIDI Parameter Number	Table
1	Rotor Speed	0.0Hz-39.70Hz	(0-127)	1	1
2	Drive Low	0-127	(0-127)	2	
3	Drive High	0-127	(0-127)	3	
4	Low/High Balance	L63>H-L=H-L<H63	(1-127)	4	
5	Mic L-R Angle	0deg-180deg	(0-60)	5	
6	Divide Frequency	100Hz-10.0kHz	(14-54)	11	3
7	EQ Low Frequency	32Hz-2.0kHz	(4-40)	6	3
8	EQ Low Gain	-12dB-+12dB	(52-76)	7	
9	EQ High Frequency	500Hz-16.0kHz	(28-58)	8	3
10	EQ High Gain	-12dB-+12dB	(52-76)	9	

**054 DISTORTION + 2-WAY ROTARY SPEAKER-055 OVERDRIVE + 2-WAY ROTARY SPEAKER**

No.	Parameter	Range	Value	MIDI Parameter Number	Table
1	Rotor Speed	0.0Hz-39.70Hz	(0-127)	1	1
2	Drive Low	0-127	(0-127)	2	
3	Drive High	0-127	(0-127)	3	
4	Low/High Balance	L63>H-L=H-L<H63	(1-127)	4	
5	Mic L-R Angle	0deg-180deg	(0-60)	12	
6	Divide Frequency	100Hz-10.0kHz	(14-54)	11	3
7	Drive	0-127	(0-127)	14	
8	Drive LPF Cutoff Freq	1.0kHz-20.0kHz	(34-60)	15	3
9	Drive Output Level	0-127	(0-127)	16	
10	EQ Low Frequency	32Hz-2.0kHz	(4-40)	6	3
11	EQ Low Gain	-12dB-+12dB	(52-76)	7	
12	EQ High Frequency	500Hz-16.0kHz	(28-58)	8	3
13	EQ High Gain	-12dB-+12dB	(52-76)	9	

**056 AMP SIM. + 2-WAY ROTARY SPEAKER**

No.	Parameter	Range	Value	MIDI Parameter Number	Table
1	Rotor Speed	0.0Hz-39.70Hz	(0-127)	1	1
2	Drive Low	0-127	(0-127)	2	
3	Drive High	0-127	(0-127)	3	
4	Low/High Balance	L63>H-L=H-L<H63	(1-127)	4	
5	Mic L-R Angle	0deg-180deg	(0-60)	12	
6	Divide Frequency	100Hz-10.0kHz	(14-54)	11	3
7	Amp Type	off, stack, combo, tube	(0-3)	13	
8	Amp Drive	0-127	(0-127)	14	
9	Amp LPF Cutoff Freq	1.0kHz-20.0kHz	(34-60)	15	3
10	Amp Output Level	0-127	(0-127)	16	
11	EQ Low Frequency	32Hz-2.0kHz	(4-40)	6	3
12	EQ Low Gain	-12dB-+12dB	(52-76)	7	
13	EQ High Frequency	500Hz-16.0kHz	(28-58)	8	3
14	EQ High Gain	-12dB-+12dB	(52-76)	9	

**057 DUAL ROTOR SPEAKER 1-059 DUAL ROTOR SPEAKER 3**

No.	Parameter	Range	Value	MIDI Parameter Number	Table
1	Speed Control	slow, fast	(0-1)	16	
2	Slow-Fast Time of Rotor	0-127	(0-127)	5	
3	Slow-Fast Time of Horn	0-127	(0-127)	6	
4	Rotor Speed Slow	0.0Hz-2.65Hz	(0-63)	1	1
5	Rotor Speed Slow	0.0Hz-2.65Hz	(0-63)	2	1
6	Rotor Speed Fast	2.692Hz-39.70Hz	(64-127)	3	1
7	Horn Speed Fast	2.692Hz-39.70Hz	(64-127)	4	1
8	Mic L-R Angle	0deg-180deg	(0-60)	15	
9	Drive Low	0-127	(0-127)	7	
10	Drive High	0-127	(0-127)	8	
11	Low/High Balance	L63>H-L=H-L<H63	(1-127)	9	
12	EQ Low Frequency	32Hz-2.0kHz	(4-40)	11	3
13	EQ Low Gain	-12dB-+12dB	(52-76)	12	
14	EQ High Frequency	500Hz-16.0kHz	(28-58)	13	3
15	EQ High Gain	-12dB-+12dB	(52-76)	14	

**060 DISTORTION, 063 OVERDRIVE**

No.	Parameter	Range	Value	MIDI Parameter Number	Table
1	Drive	0-127	(0-127)	1	
2	Edge	0-127	(0-127)	11	
3	Output Level	0-127	(0-127)	5	
4	EQ Low Frequency	32Hz-2.0kHz	(4-40)	2	3
5	EQ Low Gain	-12dB-+12dB	(52-76)	3	
6	LPF Cutoff Frequency	1.0kHz-20.0kHz	(34-60)	4	3
7	EQ Mid Frequency	100Hz-10.0kHz	(14-54)	7	3
8	EQ Mid Gain	-12dB-+12dB	(52-76)	8	
9	EQ Mid Width	0.1-12.0	(1-120)	9	
10	Dry/Wet Balance	D63>W-D=W-D<W63	(1-127)	10	

**061 COMP DISTORTION**

No.	Parameter	Range	Value	MIDI Parameter Number	Table
1	Attack	1ms-40ms	(0-19)	12	8
2	Release	10ms-680ms	(0-15)	13	9
3	Threshold	-48dB--6dB	(79-121)	14	
4	Ratio	1-20.0	(0-7)	15	10
5	EQ Low Frequency	32Hz-2.0kHz	(4-40)	2	3
6	EQ Low Gain	-12dB-+12dB	(52-76)	3	
7	Drive	0-127	(0-127)	1	
8	Output Level	0-127	(0-127)	5	
9	EQ Mid Frequency	100Hz-10.0kHz	(14-54)	7	3
10	EQ Mid Gain	-12dB-+12dB	(52-76)	8	
11	EQ Mid Width	0.1-12.0	(1-120)	9	
12	Edge	0-127	(0-127)	11	
13	LPF Cutoff Frequency	1.0kHz-20.0kHz	(34-60)	4	3
14	Dry/Wet Balance	D63>W-D=W-D<W63	(1-127)	10	

**062 V-DISTORTION**

No.	Parameter	Range	Value	MIDI Parameter Number	Table
1	Over Drive	0-100%	(0-100)	1	
2	Device	Transistor, Vintage Tube, Dsitorion1, Dsitorion2, Fuzz	(0-4)	2	
3	Speaker Type	Flat, Stack, Combo, Twin, Radio, Megaphone	(0-5)	3	
4	Presence	-10-10	(0-20)	4	
5	Lch Delay Time	0.1ms-1486.0ms	(1-14860)	6	
6	Rch Delay Time	0.1ms-1486.0ms	(1-14860)	7	
7	Feedback Time	0.1ms-1486.0ms	(1-14860)	8	
8	Feedback Level	-63-+63	(1-127)	9	
9	Feedback High Damp	0.1-1.0	(1-10)	12	
10	Dist Output Level	0-100%	(0-100)	5	
11	Delay Mix	0-127	(0-127)	11	
12	Dry/Wet Balance	D63>W-D=W-D<W63	(1-127)	10	

**064 AMP SIMULATOR**

No.	Parameter	Range	Value	MIDI Parameter Number	Table
1	AMP type	off, stack, combo, tube	(0-3)	2	
2	drive	0-127	(0-127)	1	
3	edge	0-127	(0-127)	11	
4	LPF cutoff frequency	1.0kHz-20.0kHz	(34-60)	3	3
5	output level	0-127	(0-127)	4	

**065 AMP SIMULATOR 2**

No.	Parameter	Range	Value	MIDI Parameter Number	Table
1	AMP type	off, stack, combo, tube, crunch, hi gain, british	(0-3)	2	
2	drive	0-127	(0-127)	1	
3	output level	0-127	(0-127)	4	
4	LPF cutoff frequency	1.0kHz-20.0kHz	(34-60)	3	3
5	Dry/Wet Balance	D63>W-D=W-D<W63	(1-127)	10	

**066 DIST + DELAY, 067 OVERDRIVE + DELAY**

No.	Parameter	Range	Value	MIDI Parameter Number	Table
1	Dist Drive	0-127	(0-127)	6	
2	Dist EQ Low Gain	-12dB-+12dB	(52-76)	8	
3	Dist EQ Mid Gain	-12dB-+12dB	(52-76)	9	
4	Dist Output Level	0-127	(0-127)	7	
5	Delay Time L	0.1ms-1486.0ms	(1-14860)	1	
6	Delay Time R	0.1ms-1486.0ms	(1-14860)	2	
7	Delay Feedback Time	0.1ms-1486.0ms	(1-14860)	3	
8	Delay Feedback Level	-63-+63	(1-127)	4	
9	Delay Mix	0-127	(0-127)	5	
10	Dry/Wet Balance	D63>W-D=W-D<W63	(1-127)	10	

**068 COMPRESSOR**

No.	Parameter	Range	Value	MIDI Parameter Number	Table
1	Attack	1ms-40ms	(0-19)	1	8
2	Release	10ms-680ms	(0-15)	2	9
3	Threshold	-48dB--6dB	(79-121)	3	
4	Ratio	1-20.0	(0-7)	4	10
5	Output Level	0-127	(0-127)	5	

**069 NOISE GATE**

No.	Parameter	Range	Value	MIDI Parameter Number	Table
1	Attack	1ms-40ms	(0-19)	1	8
2	Release	10ms-680ms	(0-15)	2	9
3	Threshold	-72dB--30dB	(55-97)	3	
4	Output Level	0-127	(0-127)	4	

**070 COMP + DIST + DELAY-071 COMP + OVERDRIVE + DELAY**

No.	Parameter	Range	Value	MIDI Parameter Number	Table
1	Comp Attack	1ms-40ms	(0-19)	11	8
2	Comp Release	10ms-680ms	(0-15)	12	9
3	Comp Threshold	-48dB--6dB	(79-121)	13	
4	Comp Ratio	1-20.0	(0-7)	14	10
5	Drive	0-127	(0-127)	4	
6	Drive EQ Low Gain	-12dB-+12dB	(52-76)	6	
7	Drive EQ Mid Gain	-12dB-+12dB	(52-76)	7	
8	Drive Output Level	0-127	(0-127)	5	
9	Delay Time	0.1ms-1486.0ms	(1-14860)	1	
10	Delay Feedback Level	-63-+63	(1-127)	2	
11	Delay Mix	0-127	(0-127)	3	
12	Dry/Wet Balance	D63>W-D=W-D<W63	(1-127)	10	

**072 MULTI BAND COMPRESSOR 1**

No.	Parameter	Range	Value	MIDI Parameter Number	Table
1	Type	Normal, Low, Mid, High, Low/High, Low/Mid, Mid/High, Full Bit, Wild, Attacky, Low End, Hard	(0-11)	1	
2	Threshold Offset	-32-+32	(32-96)	2	
3	Low Gain Offset	-63-+63	(1-127)	3	
4	Mid Gain Offset	-63-+63	(1-127)	4	
5	High Gain Offset	-63-+63	(1-127)	5	

**073 MULTI BAND COMPRESSOR 2**

No.	Parameter	Range	Value	MIDI Parameter Number	Table
1	Low Attack	1ms-200ms	(0-29)	1	8
2	Low Release	10ms-3000ms	(0-15)	2	9
3	Low Threshold	-54dB--6dB	(73-121)	3	
4	Low Ratio	1-20.0	(0-7)	4	10
5	Low Gain	-∞-+18dB	(0-55)	5	14
6	Mid Attack	1ms-200ms	(0-29)	6	8
7	Mid Release	10ms-3000ms	(0-15)	7	9
8	Mid Threshold	-54dB--6dB	(73-121)	8	
9	Mid Ratio	1-20.0	(0-7)	9	10
10	Mid Gain	-∞-+18dB	(0-55)	10	14
11	High Attack	1ms-200ms	(0-29)	11	8
12	High Release	10ms-3000ms	(0-15)	12	9
13	High Threshold	-54dB--6dB	(73-121)	13	
14	High Ratio	1-20.0	(0-7)	14	10
15	High Gain	-∞-+18dB	(0-55)	15	14
16	Divide Freq	32Hz, 1.2kHz-630Hz, 10.0kHz	(0-89)	16	15

**074 PITCH CHANGE 1-075 PITCH CHANGE 2**

In 075 PITCH CHANGE 2, the unit of Fine 1 and Fine 2 (numbers 5 and 6) is cent.

No.	Parameter	Range	Value	MIDI Parameter Number	Table
1	Pitch	-24-+24	(40-88)	1	
2	Initial Delay	0.1ms-248.9ms	(0-79)	2	7
3	Feedback Level	-63-+63	(1-127)	5	
4	Dry/Wet Balance	D63>W-D=W-D<W63	(1-127)	10	
5	Fine1	-50-+50	(14-114)	3	
6	Fine2	-50-+50	(14-114)	4	
7	Pan1	L63-C-R63	(1-127)	11	
8	Output Level1	0-127	(0-127)	12	
9	Pan2	L63-C-R63	(1-127)	13	
10	Output Level2	0-127	(0-127)	14	

**076 AUTO WAH**

No.	Parameter	Range	Value	MIDI Parameter Number	Table
1	LFO Speed	0.0Hz-39.70Hz	(0-127)	1	1
2	LFO Depth	0-127	(0-127)	2	
3	Cutoff Frequency Offset	0-127	(0-127)	3	
4	Resonance	1-12.0	(10-120)	4	
5	EQ Low Frequency	32Hz-2.0kHz	(4-40)	6	3
6	EQ Low Gain	-12dB-+12dB	(52-76)	7	
7	EQ High Frequency	500Hz-16.0kHz	(28-58)	8	3
8	EQ High Gain	-12dB-+12dB	(52-76)	9	

**077 AUTO WAH + DIST-078 AUTO WAH + OVERDRIVE**

No.	Parameter	Range	Value	MIDI Parameter Number	Table
1	LFO Speed	0.0Hz-39.70Hz	(0-127)	1	1
2	LFO Depth	0-127	(0-127)	2	
3	Cutoff Frequency Offset	0-127	(0-127)	3	
4	Resonance	1-12.0	(10-120)	4	
5	EQ Low Frequency	32Hz-2.0kHz	(4-40)	6	3
6	EQ Low Gain	-12dB-+12dB	(52-76)	7	
7	EQ High Frequency	500Hz-16.0kHz	(28-58)	8	3
8	EQ High Gain	-12dB-+12dB	(52-76)	9	
9	Drive	0-127	(0-127)	11	
10	Drive Low Gain	-12dB-+12dB	(52-76)	12	
11	Drive Mid Gain	-12dB-+12dB	(52-76)	13	
12	Drive LPF Cutoff Freq	1.0kHz-20.0kHz	(34-60)	14	3
13	Drive Output Level	0-127	(0-127)	15	
14	Dry/Wet Balance	D63>W-D=W-D<W63	(1-127)	10	

**079 TOUCH WAH**

No.	Parameter	Range	Value	MIDI Parameter Number	Table
1	Sensitive	0-127	(0-127)	1	
2	Cutoff Frequency Offset	0-127	(0-127)	2	
3	Resonance	1-12.0	(10-120)	3	
4	EQ Low Frequency	32Hz-2.0kHz	(4-40)	6	3
5	EQ Low Gain	-12dB-+12dB	(52-76)	7	
6	EQ High Frequency	500Hz-16.0kHz	(28-58)	8	3
7	EQ High Gain	-12dB-+12dB	(52-76)	9	
8	Dry/Wet Balance	D63>W-D=W-D<W63	(1-127)	10	

**080 TOUCH WAH + DIST-081 TOUCH WAH + OVERDRIVE**

No.	Parameter	Range	Value	MIDI Parameter Number	Table
1	Sensitive	0-127	(0-127)	1	
2	Cutoff Frequency Offset	0-127	(0-127)	2	
3	Resonance	1-12.0	(10-120)	3	
4	EQ Low Frequency	32Hz-2.0kHz	(4-40)	6	3
5	EQ Low Gain	-12dB-+12dB	(52-76)	7	
6	EQ High Frequency	500Hz-16.0kHz	(28-58)	8	3
7	EQ High Gain	-12dB-+12dB	(52-76)	9	
8	Drive	0-127	(0-127)	11	
9	Drive Low Gain	-12dB-+12dB	(52-76)	12	
10	Drive Mid Gain	-12dB-+12dB	(52-76)	13	
11	Drive LPF Cutoff Freq	1.0kHz-20.0kHz	(34-60)	14	3
12	Drive Output Level	0-127	(0-127)	15	
13	Dry/Wet Balance	D63>W-D=W-D<W63	(1-127)	10	

**082 WAH + DIST + DELAY-083 WAH + OVERDRIVE + DELAY**

No.	Parameter	Range	Value	MIDI Parameter Number	Table
1	Wah Sensitive	0-127	(0-127)	11	
2	Wah Cutoff Frequency	0-127	(0-127)	12	
3	Wah Resonance	1-12.0	(10-120)	13	
4	Wah Release	10ms-680ms	(52-67)	14	12
5	Dist Drive	0-127	(0-127)	4	
6	Dist EQ Low Gain	-12dB-+12dB	(52-76)	6	
7	Dist EQ Mid Gain	-12dB-+12dB	(52-76)	7	
8	Dist Output Level	0-127	(0-127)	5	
9	Delay Time	0.1ms-1486.0ms	(1-14860)	1	
10	Delay Feedback Level	-63-+63	(1-127)	2	
11	Delay Mix	0-127	(0-127)	3	
12	Dry/Wet Balance	D63>W-D=W-D<W63	(1-127)	10	

**084 LO-FI**

No.	Parameter	Range	Value	MIDI Parameter Number	Table
1	Sampling Freq. Control	44.1kHz-344.5Hz	(0-127)	1	
2	Word Length	1-127	(1-127)	2	
3	Output Gain	-6dB-+36dB	(0-42)	3	
4	Filter Type	thru, Power Bass, Radio, Telephone, Clean, Low	(0-5)	5	
5	Pre-LPF Cutoff Freq	63Hz-20.0kHz	(10-60)	4	3
6	Pre-LPF Resonance	1-12.0	(10-120)	6	
7	Bit Assign	0-6	(0-6)	7	
8	Emphasis	off/on	(0-1)	8	
9	Input Mode	mono/stereo	(0-1)	15	
10	Dry/Wet Balance	D63>W-D=W-D<W63	(1-127)	10	

**085 LOW RESOLUTION**

No.	Parameter	Range	Value	MIDI Parameter Number	Table
1	Mod Depth	0-127	(0-127)	2	
2	Mod Delay Offset	1-127	(1-127)	1	
3	Mod Feedback	-63-+63	(1-127)	3	
4	Mod Mix Balance	0-127	(0-127)	5	
5	Resolution	1, 1/2-1/128	(0-7)	4	
6	Phase Inverse R	off, wet	(0-1)	6	
7	Dry/Wet Balance	D63>W-D=W-D<W63	(1-127)	10	

**086 NOISY**

No.	Parameter	Range	Value	MIDI Parameter Number	Table
1	Mod Depth	0-10	(0-10)	2	
2	Mod Speed	0-127	(0-127)	3	
3	Mod Feedback	-63-+63	(1-127)	4	
4	Mod Mix Balance	1-127	(1-127)	7	
5	Drive	0-127	(0-127)	1	
6	AM Speed	0.00Hz-39.7Hz	(0-127)	5	1
7	AM Depth	0-127	(0-127)	6	
8	LPF Cutoff Frequency	1.0kHz-20.0kHz	(34-60)	8	3
9	LPF Resonance	1.0-12.0	(10-120)	9	
10	EQ Frequency	100Hz-10.0kHz	(14-54)	10	3
11	EQ Gain	-12-+12dB	(52-76)	11	
12	EQ Width	1.0-12.0	(10-120)	12	
13	Dry/Wet Balance	D63>W-D=W-D<W63	(1-127)	10	

**087 ATTACK LO-FI**

No.	Parameter	Range	Value	MIDI Parameter Number	Table
1	Sensitive	0-127	(0-127)	1	
2	Resolution	1, 1/2-1/32	(0-5)	2	
3	Peak Frequency	100Hz-10.0kHz	(14-54)	3	3
4	LPF Cutoff Frequency	1.0kHz-20.0kHz	(34-60)	4	3
5	Flanger Speed	0.00Hz-39.7Hz	(0-127)	5	1
6	Flanger LFO Wave	tri, sine, saw up, saw down	(0-3)	6	
7	Flanger Depth	0-127	(0-127)	7	
8	Flanger Depth Ofst R	-63-+63	(1-127)	8	
9	Flanger Delay	0.1-650.0ms	(1-6500)	9	
10	Flanger Delay Ofst R	0-884	(0-884)	10	
11	Flanger Feedback	-63-+63	(1-127)	11	
12	Flanger Feedback Ofst R	-63-+63	(1-127)	12	
13	Flanger Feedback HiDamp	0.1-1.0	(1-10)	13	
14	Feedback HiDamp Ofst R	-0.9-+0.9	(1-19)	14	
15	Flanger Mix Balance	1-127	(1-127)	15	
16	Dry/Wet Balance	D63>W-D=W-D<W63	(1-127)	10	

**088 DIGITAL TURNTABLE**

No.	Parameter	Range	Value	MIDI Parameter Number	Table
1	Click Density	0-5	(0-5)	1	
2	Click Level	0-127	(0-127)	2	
3	Noise Tone	0-6	(0-6)	3	
4	Dry Send to Noise	0-127	(0-127)	6	
5	Noise Mod Speed	0.00Hz-39.7Hz	(0-127)	4	1
6	Noise Mod Depth	0-127	(0-127)	5	
7	Noise LPF Freq	1.0kHz-20.0kHz	(34-60)	7	3
8	Noise LPF Q	1.0-12.0	(10-120)	8	
9	Noise Level	0-127	(0-127)	9	
10	Dry LPF Frequency	1.0kHz-20.0kHz	(34-60)	10	3
11	Dry Level	0-127	(0-127)	11	

### 089 DIGITAL SCRATCH

No.	Parameter	Range	Value	MIDI Parameter Number	Table
1	Input Level	0-127	(0-127)	1	
2	Initial Delay	0.1-460.0ms	(1-4600)	2	
3	Scratch Speed	1-127	(1-127)	3	
4	Scratch Depth	0-127	(0-127)	4	
5	HPF Cutoff Frequency	20Hz-8.0kHz	(0-52)	10	3
6	Auto Pan Speed	0.00Hz-39.7Hz	(0-127)	5	1
7	Auto Pan Depth	0-127	(0-127)	6	
8	EQ Frequency	100Hz-10.0kHz	(14-54)	7	3
9	EQ Gain	-12-+12dB	(52-76)	8	
10	EQ Width	1.0-12.0	(10-120)	9	
11	Dry/Wet Balance	D63>W-D=W-D<W63	(1-127)	10	

### 090 AUTO SYNTH

No.	Parameter	Range	Value	MIDI Parameter Number	Table
1	Mod Speed	0-127	(0-127)	1	
2	Mod Wave Type	typeA, typeB, typeC, typeD	(0-3)	2	
3	Mod Depth	0-127	(0-127)	3	
4	Mod Depth Ofst R	-63-+63	(1-127)	4	
5	HPF Frequency	20Hz-8.0kHz	(0-52)	6	3
6	LPF Frequency	1.0kHz-20.0kHz	(34-60)	5	3
7	Dry Mix Level	0-127	(0-127)	7	
8	Delay Level	0-127	(0-127)	10	
9	Delay Time	0.1-370.0ms	(1-3700)	8	
10	Delay Time Ofst R	0-884	(0-884)	9	
11	Feedback Level	-63-+63	(1-127)	10	
12	FB Level Ofst R	-63-+63	(1-127)	11	
13	AM Speed	0.00Hz-39.7Hz	(0-127)	13	1
14	AM Wave	tri, sine, saw up, saw down	(0-3)	14	
15	AM Depth	0-127	(0-127)	15	
16	AM Inverse R	normal, inverse	(0-1)	16	

### 091 TECH MODULATION

No.	Parameter	Range	Value	MIDI Parameter Number	Table
1	Mod Speed	0-127	(0-127)	1	
2	Mod Depth	0-127	(0-127)	2	
3	Mod Gain	-12-+12dB	(52-76)	4	
4	Mod Mix Balance	D63>W-D=W-D<W63	(1-127)	7	
5	Pre Mod HPF Cutoff Freq	20Hz-8.0kHz	(0-52)	3	3
6	Mod LPF Cutoff Freq	1.0kHz-20.0kHz	(34-60)	5	3
7	Mod LPF Resonance	1.0-12.0	(10-120)	6	
8	Delay Time	0.1-740.0ms	(1-7400)	8	
9	Delay Time Ofst R	0-884	(0-884)	9	
10	Feedback Level	-63-+63	(1-127)	10	
11	Feedback Level Ofst R	-63-+63	(1-127)	11	
12	Feedback Hi Damp	0.1-1.0	(1-10)	12	
13	Feedback Hi Damp Ofst R	-0.9-+0.9	(1-19)	13	
14	Dry/Wet Balance	D63>W-D=W-D<W63	(1-127)	10	

### 092 JUMP

No.	Parameter	Range	Value	MIDI Parameter Number	Table
1	Depth	0-127	(0-127)	1	
2	Speed	0-127	(0-127)	2	
3	Direction	L<>R, L>>R	(0-1)	3	
4	Type	typeA, typeB, typeC	(0-2)	4	
5	Jump Wave Type	typeA, typeB, typeC, typeD	(0-3)	5	
6	Resolution	1, 1/2- 1/256	(0-8)	6	
7	HPF Frequency	20Hz-8.0kHz	(0-52)	8	3
8	LPF Frequency	1.0kHz-20.0kHz	(34-60)	7	3
9	Dry/Wet Balance	D63>W-D=W-D<W63	(1-127)	10	

### 093 ISOLATION

No.	Parameter	Range	Value	MIDI Parameter Number	Table
1	On/off SW	off, on	(0-1)	1	
2	Low Level	0-127	(0-127)	2	
3	Mid Level	0-127	(0-127)	3	
4	High Level	0-127	(0-127)	4	
5	Low Mute	off/on	(0-1)	5	
6	Mid Mute	off/on	(0-1)	6	
7	High Mute	off/on	(0-1)	7	

### 094 SLICE

No.	Parameter	Range	Value	MIDI Parameter Number	Table
1	Divide Type	4th, 8th, 16th	(0-2)	1	
2	Gate Time	0-100%	(0-100)	2	
3	Pan AEG Type	A-E	(0-4)	3	
4	Pan AEG Min Level	0-127	(0-127)	4	
5	Pan Depth	-63-+63	(1-127)	5	
6	Divide Min Level	0-127	(0-127)	6	
7	Pan Type	A-J	(0-9)	7	
8	Drive	0-127	(0-127)	8	
9	AEG Phase	0-15 (x16th note)	(0-15)	9	
10	Dry/Wet Balance	D63>W-D=W-D<W63	(1-127)	10	
11	EQ low frequency	32Hz-2.0kHz	(4-40)	13	3
12	EQ low gain	-12dB-+12dB	(52-76)	14	
13	EQ high frequency	500Hz-16.0kHz	(28-58)	15	3
14	EQ high gain	-12dB-+12dB	(52-76)	16	

### 095 3-BAND EQ

No.	Parameter	Range	Value	MIDI Parameter Number	Table
1	EQ Low Frequency	50Hz-2.0kHz	(8-40)	6	3
2	EQ Low Gain	-12dB-+12dB	(52-76)	1	
3	EQ High Frequency	500Hz-16.0kHz	(28-58)	7	3
4	EQ High Gain	-12dB-+12dB	(52-76)	5	
5	EQ Mid Frequency	100H-10.0kHz	(14-54)	2	3
6	EQ Mid Gain	-12dB-+12dB	(52-76)	3	
7	EQ Mid Width	0.1-12.0	(1-120)	4	
8	Input Mode	mono/stereo	(0-1)	15	

### 096 2-BAND EQ

No.	Parameter	Range	Value	MIDI Parameter Number	Table
1	EQ Low Frequency	32Hz-2.0kHz	(4-40)	1	3
2	EQ Low Gain	-12dB-+12dB	(52-76)	2	
3	EQ High Frequency	500Hz-16.0kHz	(28-58)	3	3
4	EQ High Gain	-12dB-+12dB	(52-76)	4	

### 097 HARMONIC ENHANCER

No.	Parameter	Range	Value	MIDI Parameter Number	Table
1	HPF Cutoff Frequency	500Hz-16.0kHz	(28-58)	1	3
2	Drive	0-127	(0-127)	2	
3	Mix Level	0-127	(0-127)	3	

### 098 VOICE CANCEL

No.	Parameter	Range	Value	MIDI Parameter Number	Table
1	Low Adjust	0-26	(0-26)	11	
2	High Adjust	0-26	(0-26)	12	

### 099 AMBIENCE

No.	Parameter	Range	Value	MIDI Parameter Number	Table
1	Delay Time	0.0ms-50.0ms	(0-127)	1	2
2	Wet Output Phase	normal/inverse	(0-1)	2	
3	Dry/Wet Balance	D63>W-D=W-D<W63	(1-127)	10	
4	EQ Low Frequency	32Hz-2.0kHz	(4-40)	6	3
5	EQ Low Gain	-12dB-+12dB	(52-76)	7	
6	EQ High Frequency	500Hz-16.0kHz	(28-58)	8	3
7	EQ High Gain	-12dB-+12dB	(52-76)	9	

### 100 TALKING MODULATOR

No.	Parameter	Range	Value	MIDI Parameter Number	Table
1	Vowel	a/i/u/e/o	(0-4)	1	
2	Move Speed	1-62	(1-62)	2	
3	Drive	0-127	(0-127)	3	
4	Output Level	0-127	(0-127)	4	

#### 101 BEAT CHANGE

No.	Parameter	Range	Value	MIDI Parameter Number	Table
1	BeatChange	-63~+63	(1-127)	1	
2	Beat Range	0-12	(0-12)	2	
3	PitchChange	-63~+63	(1-127)	3	
4	Pitch Range	0-12	(0-12)	4	
5	EQ Frequency	32Hz~2.0kHz	(4-40)	6	
6	EQ Gain	-12dB~+12dB	(52-76)	7	
7	EQ Width	1.0-12.0	(10-120)	8	
8	Accuracy Type	sound4-normal-rythm4	(0-8)	5	
9	Dry/Wet Balance	D63>W-D=W-D<W63	(1-127)	10	

#### 102 RING MODULATOR

No.	Parameter	Range	Value	MIDI Parameter Number	Table
1	Carrier Freq Coarse	0.5 - 5kHz	(0-127)	1	16
2	Carrier Freq Fine	0-127	(0-127)	2	
3	LFO Wave	tri, sine	(0-1)	3	
4	LFO Depth	0-127	(0-127)	4	
5	LFO Speed	0.0Hz~39.70Hz	(0-127)	5	1
6	HPF Cutoff Frequency	20Hz~8.0kHz	(0-52)	6	3
7	LPF Cutoff Frequency	1.0kHz~20.0kHz	(34-60)	7	3
8	Dry/Wet Balance	D63>W-D=W-D<W63	(1-127)	10	
9	EQ Low Frequency	32Hz~2.0kHz	(4-40)	13	3
10	EQ Low Gain	-12dB~+12dB	(52-76)	14	
11	EQ High Frequency	500Hz~16.0kHz	(28-58)	15	3
12	EQ High Gain	-12dB~+12dB	(52-76)	16	

#### 103 DYNAMIC RING MODULATOR

No.	Parameter	Range	Value	MIDI Parameter Number	Table
1	Sensitivity	0-127	(0-127)	1	
2	HPF Cutoff Frequency	20Hz~8.0kHz	(0-52)	2	3
3	LPF Cutoff Frequency	1.0kHz~20.0kHz	(34-60)	3	3
4	Attack Time	0.3ms~227ms	(0-127)	4	17
5	Release Time	2.6ms~2171ms	(0-127)	5	18
6	Release Curve	0-127	(0-127)	6	
7	Direction	up, down	(0-1)	7	
8	Dyna Threshold Level	0-127	(0-127)	8	
9	Dyna Level Offset	0-127	(0-127)	9	
10	Dry/Wet Balance	D63>W-D=W-D<W63	(1-127)	10	
11	EQ Low Frequency	32Hz~2.0kHz	(4-40)	13	3
12	EQ Low Gain	-12dB~+12dB	(52-76)	14	
13	EQ High Frequency	500Hz~16.0kHz	(28-58)	15	3
14	EQ High Gain	-12dB~+12dB	(52-76)	16	

#### 104 DYNAMIC FILTER

No.	Parameter	Range	Value	MIDI Parameter Number	Table
1	Filter Type	LPF(12dB), LPF(18dB), LPF(24dB), HPF, BPF, BEF	(0-5)	1	
2	Sensitivity	0-127	(0-127)	2	
3	Dyna Level Offset	0-127	(0-127)	3	
4	Resonance	-16~+111	(0-127)	4	
5	Attack Time	0.3ms~227ms	(0-127)	5	17
6	Release Time	2.6ms~2171ms	(0-127)	6	18
7	Release Curve	0-127	(0-127)	7	
8	Direction	up, down	(0-1)	8	
9	Dyna Threshold Level	0-127	(0-127)	9	
10	Dry/Wet Balance	D63>W-D=W-D<W63	(1-127)	10	
11	EQ Low Frequency	32Hz~2.0kHz	(4-40)	13	3
12	EQ Low Gain	-12dB~+12dB	(52-76)	14	
13	EQ High Frequency	500Hz~16.0kHz	(28-58)	15	3
14	EQ High Gain	-12dB~+12dB	(52-76)	16	

## 4. Insertin Effect 1/Variation Effect (Performance Mode only)

#### 01 CHORUS 1-08 CELESTE 4

No.	Parameter	Range	Value	MIDI Parameter Number	Table
1	LFO Speed	0.0Hz~39.70Hz	(0-127)	1	1
2	LFO Depth	0-127	(0-127)	2	
3	Input Mode	mono/stereo	(0-1)	9	
4	EQ Low Frequency	32Hz~2.0kHz	(4-40)	5	3
5	EQ Low Gain	-12dB~+12dB	(52-76)	6	
6	EQ High Frequency	500Hz~16.0kHz	(28-58)	7	3
7	EQ High Gain	-12dB~+12dB	(52-76)	8	
8	Delay Offset	0.0ms~50.0ms	(0-127)	4	2
9	Feedback Level	-63~+63	(1-127)	3	
10	Dry / Wet Balance	D63>W-D=W-D<W63	(1-127)	10	

#### 09 FLANGER 1-11 FLANGER 3

No.	Parameter	Range	Value	MIDI Parameter Number	Table
1	LFO Speed	0.0Hz~39.70Hz	(0-127)	1	1
2	LFO Depth	0-127	(0-127)	2	
3	LFO Phase Difference	-180deg~+180deg	(4-124)	9	
4	EQ Low Frequency	32Hz~2.0kHz	(4-40)	5	
5	EQ Low Gain	-12dB~+12dB	(52-76)	6	
6	EQ High Frequency	500Hz~16.0kHz	(28-58)	7	
7	EQ High Gain	-12dB~+12dB	(52-76)	8	
8	Delay Offset	0.0ms~50.0ms	(0-127)	4	2
9	Feedback Level	-63~+63	(1-127)	3	
10	Dry / Wet Balance	D63>W-D=W-D<W63	(1-127)	10	

#### 12 PHASER 1

No.	Parameter	Range	Value	MIDI Parameter Number	Table
1	LFO Speed	0.0Hz~39.70Hz	(0-127)	1	1
2	LFO Depth	0-127	(0-127)	2	
3	EQ Low Frequency	32Hz~2.0kHz	(4-40)	6	
4	EQ Low Gain	-12dB~+12dB	(52-76)	7	3
5	EQ High Frequency	500Hz~16.0kHz	(28-58)	8	
6	EQ High Gain	-12dB~+12dB	(52-76)	9	3
7	Stage	4, 5, 6	(4-6)	5	
8	Phase Shift Offset	0-127	(0-127)	3	
9	Feedback Level	-63~+63	(1-127)	4	
10	Dry / Wet Balance	D63>W-D=W-D<W63	(1-127)	10	

#### 13 TREMOLO

No.	Parameter	Range	Value	MIDI Parameter Number	Table
1	LFO Speed	0.0Hz~39.70Hz	(0-127)	1	1
2	AM Depth	0-127	(0-127)	2	
3	PM Depth	0-127	(0-127)	3	
4	LFO Phase Difference	-180deg~+180deg	(4-124)	4	
5	EQ Low Frequency	32Hz~2.0kHz	(4-40)	5	3
6	EQ Low Gain	-12dB~+12dB	(52-76)	6	
7	EQ High Frequency	500Hz~16.0kHz	(28-58)	7	3
8	EQ High Gain	-12dB~+12dB	(52-76)	8	
9	Input Mode	mono/stereo	(0-1)	9	

#### 14 AUTO PAN

No.	Parameter	Range	Value	MIDI Parameter Number	Table
1	LFO Speed	0.0Hz~39.70Hz	(0-127)	1	1
2	L/R Depth	0-127	(0-127)	2	
3	F/R Depth	0-127	(0-127)	3	
4	PAN Direction	L<>R, L>>R, L<<R, Lturn, Rturn, L/R	(0-5)	4	
5	EQ Low Frequency	32Hz~2.0kHz	(4-40)	5	3
6	EQ Low Gain	-12dB~+12dB	(52-76)	6	
7	EQ High Frequency	500Hz~16.0kHz	(28-58)	7	3
8	EQ High Gain	-12dB~+12dB	(52-76)	8	



### 15 DISTORTION, 16 OVERDRIVE

No.	Parameter	Range	Value	MIDI Parameter Number	Table
1	Drive	0-127	(0-127)	1	
2	Edge	0-127	(0-127)	8	
3	Output Level	0-127	(0-127)	9	
4	EQ Low Frequency	32Hz-2.0kHz	(4-40)	2	3
5	EQ Low Gain	-12dB~+12dB	(52-76)	3	
6	LPF Cutoff Frequency	1.0kHz-20.0kHz	(34-60)	7	3
7	EQ Mid Frequency	100Hz-10.0kHz	(14-54)	4	3
8	EQ Mid Gain	-12dB~+12dB	(52-76)	5	
9	EQ Mid Width	0.1-12.0	(1-120)	6	
10	Dry / Wet Balance	D63>W-D=W-D<W63	(1-127)	10	

### 17 AMP SIMULATOR

No.	Parameter	Range	Value	MIDI Parameter Number	Table
1	AMP type	off, stack, combo, tube	(0-3)	2	
2	drive	0-127	(0-127)	1	
3	edge	0-127	(0-127)	4	
4	output level	0-127	(0-127)	5	
5	LPF cutoff frequency	1.0kHz-20.0kHz	(34-60)	3	3
6	Dry / Wet Balance	D63>W-D=W-D<W63	(1-127)	6	

### 18 AMP SIMULATOR 2

No.	Parameter	Range	Value	MIDI Parameter Number	Table
1	AMP type	off, stack, combo, tube, crunch, hi gain, british	(0-3)	2	
2	drive	0-127	(0-127)	1	
3	output level	0-127	(0-127)	4	
4	LPF cutoff frequency	1.0kHz-20.0kHz	(34-60)	3	3
5	Dry / Wet Balance	D63>W-D=W-D<W63	(1-127)	5	

### 19 COMPRESSOR

No.	Parameter	Range	Value	MIDI Parameter Number	Table
1	Attack	1ms-40ms	(0-19)	1	8
2	Release	10ms-680ms	(0-15)	2	9
3	Threshold	-48dB~-6dB	(79-121)	3	
4	Ratio	1-20.0	(0-7)	4	10
5	Output Level	0-127	(0-127)	5	

### 20 NOISE GATE

No.	Parameter	Range	Value	MIDI Parameter Number	Table
1	Attack	1ms-40ms	(0-19)	1	8
2	Release	10ms-680ms	(0-15)	2	9
3	Threshold	-72dB~-30dB	(55-97)	3	
4	Output Level	0-127	(0-127)	4	

### 21 AUTO WAH

No.	Parameter	Range	Value	MIDI Parameter Number	Table
1	LFO Speed	0.0Hz-39.70Hz	(0-127)	1	1
2	LFO Depth	0-127	(0-127)	2	
3	Cutoff Frequency Offset	0-127	(0-127)	3	
4	Resonance	1-12.0	(10-120)	4	
5	EQ Low Frequency	32Hz-2.0kHz	(4-40)	5	3
6	EQ Low Gain	-12dB~+12dB	(52-76)	6	
7	EQ High Frequency	500Hz-16.0kHz	(28-58)	7	3
8	EQ High Gain	-12dB~+12dB	(52-76)	8	
9	Dry / Wet Balance	D63>W-D=W-D<W63	(1-127)	9	

### 22 TOUCH WAH

No.	Parameter	Range	Value	MIDI Parameter Number	Table
1	Sensitive	0-127	(0-127)	1	
2	Cutoff Frequency Offset	0-127	(0-127)	2	
3	Resonance	1-12.0	(10-120)	3	
4	EQ Low Frequency	32Hz-2.0kHz	(4-40)	4	3
5	EQ Low Gain	-12dB~+12dB	(52-76)	5	
6	EQ High Frequency	500Hz-16.0kHz	(28-58)	6	3
7	EQ High Gain	-12dB~+12dB	(52-76)	7	
9	Dry / Wet Balance	D63>W-D=W-D<W63	(1-127)	8	

### 23 3-BAND EQ

No.	Parameter	Range	Value	MIDI Parameter Number	Table
1	EQ Low Frequency	50Hz-2.0kHz	(8-40)	1	3
2	EQ Low Gain	-12dB~+12dB	(52-76)	2	
3	EQ High Frequency	500Hz-16.0kHz	(28-58)	6	3
4	EQ High Gain	-12dB~+12dB	(52-76)	7	
5	EQ Mid Frequency	100Hz-10.0kHz	(14-54)	3	3
6	EQ Mid Gain	-12dB~+12dB	(52-76)	4	
7	EQ Mid Width	0.1-12.0	(1-120)	5	
8	Input Mode	mono/stereo	(0-1)	8	

### 24 2-BAND EQ

No.	Parameter	Range	Value	MIDI Parameter Number	Table
1	EQ Low Frequency	32Hz-2.0kHz	(4-40)	1	3
2	EQ Low Gain	-12dB~+12dB	(52-76)	2	
3	EQ High Frequency	500Hz-16.0kHz	(28-58)	3	3
4	EQ High Gain	-12dB~+12dB	(52-76)	4	

### 25 HARMONIC ENHANCER

No.	Parameter	Range	Value	MIDI Parameter Number	Table
1	HPF Cutoff Frequency	500Hz-16.0kHz	(28-58)	1	3
2	Drive	0-127	(0-127)	2	
3	Mix Level	0-127	(0-127)	3	

# Effect Data Assign Table

**Table#1**  
LFO Frequency

Data	Value	Data	Value	Data	Value	Data	Value
0	0.00	32	1.35	64	2.69	96	8.41
1	0.04	33	1.39	65	2.78	97	8.75
2	0.08	34	1.43	66	2.86	98	9.08
3	0.13	35	1.47	67	2.94	99	9.42
4	0.17	36	1.51	68	3.03	100	9.76
5	0.21	37	1.56	69	3.11	101	10.1
6	0.25	38	1.60	70	3.20	102	10.8
7	0.29	39	1.64	71	3.28	103	11.4
8	0.34	40	1.68	72	3.37	104	12.1
9	0.38	41	1.72	73	3.45	105	12.8
10	0.42	42	1.77	74	3.53	106	13.5
11	0.46	43	1.81	75	3.62	107	14.1
12	0.51	44	1.85	76	3.70	108	14.8
13	0.55	45	1.89	77	3.87	109	15.5
14	0.59	46	1.94	78	4.04	110	16.2
15	0.63	47	1.98	79	4.21	111	16.8
16	0.67	48	2.02	80	4.37	112	17.5
17	0.72	49	2.06	81	4.54	113	18.2
18	0.76	50	2.10	82	4.71	114	19.5
19	0.80	51	2.15	83	4.88	115	20.9
20	0.84	52	2.19	84	5.05	116	22.2
21	0.88	53	2.23	85	5.22	117	23.6
22	0.93	54	2.27	86	5.38	118	24.9
23	0.97	55	2.31	87	5.55	119	26.2
24	1.01	56	2.36	88	5.72	120	27.6
25	1.05	57	2.40	89	6.06	121	28.9
26	1.09	58	2.44	90	6.39	122	30.3
27	1.14	59	2.48	91	6.73	123	31.6
28	1.18	60	2.52	92	7.07	124	33.0
29	1.22	61	2.57	93	7.40	125	34.3
30	1.26	62	2.61	94	7.74	126	37.0
31	1.30	63	2.65	95	8.08	127	39.7

**Table#4**  
Reverb Time

Data	Value	Data	Value	Data	Value	Data	Value
0	0.3	32	3.5	64	17.0		
1	0.4	33	3.6	65	18.0		
2	0.5	34	3.7	66	19.0		
3	0.6	35	3.8	67	20.0		
4	0.7	36	3.9	68	25.0		
5	0.8	37	4.0	69	30.0		
6	0.9	38	4.1				
7	1.0	39	4.2				
8	1.1	40	4.3				
9	1.2	41	4.4				
10	1.3	42	4.5				
11	1.4	43	4.6				
12	1.5	44	4.7				
13	1.6	45	4.8				
14	1.7	46	4.9				
15	1.8	47	5.0				
16	1.9	48	5.5				
17	2.0	49	6.0				
18	2.1	50	6.5				
19	2.2	51	7.0				
20	2.3	52	7.5				
21	2.4	53	8.0				
22	2.5	54	8.5				
23	2.6	55	9.0				
24	2.7	56	9.5				
25	2.8	57	10.0				
26	2.9	58	11.0				
27	3.0	59	12.0				
28	3.1	60	13.0				
29	3.2	61	14.0				
30	3.3	62	15.0				
31	3.4	63	16.0				

**Table#7**  
Delay Time (400.0ms)

Data	Value	Data	Value	Data	Value	Data	Value
0	0.1	32	100.9	64	201.6	96	302.4
1	3.2	33	104.0	65	204.8	97	305.5
2	6.4	34	107.2	66	207.9	98	308.7
3	9.5	35	110.3	67	211.1	99	311.8
4	12.7	36	113.5	68	214.2	100	315.0
5	15.8	37	116.6	69	217.4	101	318.1
6	19.0	38	119.8	70	220.5	102	321.3
7	22.1	39	122.9	71	223.7	103	324.4
8	25.3	40	126.1	72	226.8	104	327.6
9	28.4	41	129.2	73	230.0	105	330.7
10	31.6	42	132.4	74	233.1	106	333.9
11	34.7	43	135.5	75	236.3	107	337.0
12	37.9	44	138.6	76	239.4	108	340.2
13	41.0	45	141.8	77	242.6	109	343.3
14	44.2	46	144.9	78	245.7	110	346.5
15	47.3	47	148.1	79	248.9	111	349.6
16	50.5	48	151.2	80	252.0	112	352.8
17	53.6	49	154.4	81	255.2	113	355.9
18	56.8	50	157.5	82	258.3	114	359.1
19	59.9	51	160.7	83	261.5	115	362.2
20	63.1	52	163.8	84	264.6	116	365.4
21	66.2	53	167.0	85	267.7	117	368.5
22	69.4	54	170.1	86	270.9	118	371.7
23	72.5	55	173.3	87	274.0	119	374.8
24	75.7	56	176.4	88	277.2	120	378.0
25	78.8	57	179.6	89	280.3	121	381.1
26	82.0	58	182.7	90	283.5	122	384.3
27	85.1	59	185.9	91	286.6	123	387.4
28	88.3	60	189.0	92	289.8	124	390.6
29	91.4	61	192.2	93	292.9	125	393.7
30	94.6	62	195.3	94	296.1	126	396.9
31	97.7	63	198.5	95	299.2	127	400.0

**Table#11**  
Reverb Width; Depth; Height

Data	Value	Data	Value	Data	Value	Data	Value
0	0.5	32	8.8	64	17.6	96	27.5
1	0.8	33	9.1	65	17.9	97	27.8
2	1.0	34	9.4	66	18.2	98	28.1
3	1.3	35	9.6	67	18.5	99	28.5
4	1.5	36	9.9	68	18.8	100	28.8
5	1.8	37	10.2	69	19.1	101	29.2
6	2.0	38	10.4	70	19.4	102	29.5
7	2.3	39	10.7	71	19.7	103	29.9
8	2.6	40	11.0	72	20.0	104	30.2
9	2.8	41	11.2	73	20.2		
10	3.1	42	11.5	74	20.5		
11	3.3	43	11.8	75	20.8		
12	3.6	44	12.1	76	21.1		
13	3.9	45	12.3	77	21.4		
14	4.1	46	12.6	78	21.7		
15	4.4	47	12.9	79	22.0		
16	4.6	48	13.1	80	22.4		
17	4.9	49	13.4	81	22.7		
18	5.2	50	13.7	82	23.0		
19	5.4	51	14.0	83	23.3		
20	5.7	52	14.2	84	23.6		
21	5.9	53	14.5	85	23.9		
22	6.2	54	14.8	86	24.2		
23	6.5	55	15.1	87	24.5		
24	6.7	56	15.4	88	24.9		
25	7.0	57	15.6	89	25.2		
26	7.2	58	15.9	90	25.5		
27	7.5	59	16.2	91	25.8		
28	7.8	60	16.5	92	26.1		
29	8.0	61	16.8	93	26.5		
30	8.3	62	17.1	94	26.8		
31	8.6	63	17.3	95	27.1		

**Table#2**  
Modulation Delay Offset

Data	Value	Data	Value	Data	Value	Data	Value
0	0.0	32	3.2	64	6.4	96	9.6
1	0.1	33	3.3	65	6.5	97	9.7
2	0.2	34	3.4	66	6.6	98	9.8
3	0.3	35	3.5	67	6.7	99	9.9
4	0.4	36	3.6	68	6.8	100	10.0
5	0.5	37	3.7	69	6.9	101	11.1
6	0.6	38	3.8	70	7.0	102	12.2
7	0.7	39	3.9	71	7.1	103	13.3
8	0.8	40	4.0	72	7.2	104	14.4
9	0.9	41	4.1	73	7.3	105	15.5
10	1.0	42	4.2	74	7.4	106	17.1
11	1.1	43	4.3	75	7.5	107	18.6
12	1.2	44	4.4	76	7.6	108	20.2
13	1.3	45	4.5	77	7.7	109	21.8
14	1.4	46	4.6	78	7.8	110	23.3
15	1.5	47	4.7	79	7.9	111	24.9
16	1.6	48	4.8	80	8.0	112	26.5
17	1.7	49	4.9	81	8.1	113	28.0
18	1.8	50	5.0	82	8.2	114	29.6
19	1.9	51	5.1	83	8.3	115	31.2
20	2.0	52	5.2	84	8.4	116	32.8
21	2.1	53	5.3	85	8.5	117	34.3
22	2.2	54	5.4	86	8.6	118	35.9
23	2.3	55	5.5	87	8.7	119	37.5
24	2.4	56	5.6	88	8.8	120	39.0
25	2.5	57	5.7	89	8.9	121	40.6
26	2.6	58	5.8	90	9.0	122	42.2
27	2.7	59	5.9	91	9.1	123	43.7
28	2.8	60	6.0	92	9.2	124	45.3
29	2.9	61	6.1	93	9.3	125	46.9
30	3.0	62	6.2	94	9.4	126	48.4
31	3.1	63	6.3	95	9.5	127	50.0

**Table#5**  
Delay Time (200.0ms)

Data	Value	Data	Value	Data	Value	Data	Value
0	0.1	32	50.5	64	100.8	96	151.2
1	1.7	33	52.0	65	102.4	97	152.8
2	3.2	34	53.6	66	104.0	98	154.4
3	4.8	35	55.2	67	105.6	99	155.9
4	6.4	36	56.8	68	107.1	100	157.5
5	8.0	37	58.3	69	108.7	101	159.1
6	9.5	38	59.9	70	110.3	102	160.6
7	11.1	39	61.5	71	111.9	103	162.2
8	12.7	40	63.1	72	113.4	104	163.8
9	14.3	41	64.6	73	115.0	105	165.4
10	15.8	42	66.2	74	116.6	106	166.9
11	17.4	43	67.8	75	118.2	107	168.5
12	19.0	44	69.4	76	119.7	108	170.1
13	20.6	45	70.9	77	121.3	109	171.7
14	22.1	46	72.5	78	122.9	110	173.2
15	23.7						

**Table#14**  
Multi Compressor Gain

Data	Value	Data	Value
0	--	32	-5
1	-60	33	-4
2	-57	34	-3
3	-54	35	-2
4	-51	36	-1
5	-48	37	0
6	-45	38	1
7	-42	39	2
8	-39	40	3
9	-36	41	4
10	-33	42	5
11	-30	43	6
12	-27	44	7
13	-24	45	8
14	-23	46	9
15	-22	47	10
16	-21	48	11
17	-20	49	12
18	-19	50	13
19	-18	51	14
20	-17	52	15
21	-16	53	16
22	-15	54	17
23	-14	55	18
24	-13		
25	-12		
26	-11		
27	-10		
28	-9		
29	-8		
30	-7		
31	-6		

**Table#16**  
Carrier Frequency Coarse

Data	Value	Data	Value	Data	Value	Data	Value
0	0.5	32	25.7	64	152	96	895
1	1.5	33	27.1	65	160	97	946
2	2.0	34	28.7	66	169	98	1.00k
3	2.5	35	30.3	67	179	99	1.05k
4	3.5	36	32.0	68	189	100	1.11k
5	4.0	37	33.9	69	200	101	1.18k
6	4.5	38	35.8	70	211	102	1.24k
7	5.5	39	37.8	71	224	103	1.32k
8	6.0	40	40.0	72	236	104	1.39k
9	6.5	41	42.3	73	250	105	1.47k
10	7.5	42	44.7	74	264	106	1.55k
11	8.0	43	47.3	75	279	107	1.64k
12	8.5	44	49.9	76	295	108	1.74k
13	8.9	45	52.8	77	312	109	1.84k
14	9.4	46	55.8	78	330	110	1.94k
15	10.0	47	59.0	79	348	111	2.05k
16	10.6	48	62.4	80	368	112	2.17k
17	11.2	49	65.9	81	389	113	2.29k
18	11.8	50	69.7	82	412	114	2.43k
19	12.5	51	73.7	83	435	115	2.56k
20	13.2	52	77.9	84	460	116	2.71k
21	13.9	53	82.3	85	486	117	2.87k
22	14.7	54	87.0	86	514	118	3.03k
23	15.6	55	92.0	87	543	119	3.20k
24	16.5	56	97.2	88	574	120	3.39k
25	17.4	57	103	89	607	121	3.58k
26	18.4	58	109	90	642	122	3.79k
27	19.4	59	115	91	678	123	4.00k
28	20.6	60	121	92	717	124	4.23k
29	21.7	61	128	93	758	125	4.47k
30	23.0	62	136	94	801	126	4.73k
31	24.3	63	143	95	847	127	5.00k

**Table#18**  
Dynamic Release Time

Data	Value	Data	Value	Data	Value	Data	Value
0	2.6	32	87	64	369	96	1064
1	3.0	33	91	65	391	97	1086
2	3.4	34	96	66	413	98	1107
3	3.9	35	100	67	434	99	1129
4	4.3	36	104	68	456	100	1151
5	4.7	37	109	69	478	101	1173
6	5.2	38	113	70	499	102	1194
7	5.6	39	117	71	521	103	1216
8	6.0	40	122	72	543	104	1238
9	6.5	41	126	73	565	105	1259
10	6.9	42	130	74	586	106	1281
11	7.3	43	135	75	608	107	1303
12	7.8	44	139	76	630	108	1346
13	8.2	45	143	77	651	109	1390
14	8.6	46	148	78	673	110	1433
15	13	47	152	79	695	111	1477
16	17	48	156	80	717	112	1520
17	22	49	161	81	738	113	1563
18	26	50	165	82	760	114	1607
19	30	51	169	83	782	115	1650
20	35	52	174	84	803	116	1694
21	39	53	178	85	825	117	1737
22	43	54	182	86	847	118	1781
23	48	55	187	87	869	119	1824
24	52	56	195	88	890	120	1867
25	56	57	217	89	912	121	1911
26	61	58	239	90	934	122	1954
27	65	59	261	91	955	123	1998
28	69	60	282	92	977	124	2041
29	74	61	304	93	999	125	2085
30	78	62	326	94	1021	126	2128
31	83	63	347	95	1042	127	2171

**Table#20**  
Delay Time (1480.0ms)

Data	Value	Data	Value	Data	Value	Data	Value
0	1	32	900	64	4100	96	8600
1	2	33	1000	65	4200	97	8800
2	5	34	1100	66	4300	98	9000
3	10	35	1200	67	4400	99	9200
4	15	36	1300	68	4500	100	9400
5	20	37	1400	69	4600	101	9600
6	30	38	1500	70	4700	102	9800
7	40	39	1600	71	4800	103	10000
8	50	40	1700	72	4900	104	10200
9	60	41	1800	73	5000	105	10400
10	70	42	1900	74	5100	106	10600
11	80	43	2000	75	5200	107	10800
12	90	44	2100	76	5300	108	11000
13	100	45	2200	77	5400	109	11200
14	120	46	2300	78	5500	110	11400
15	140	47	2400	79	5600	111	11600
16	160	48	2500	80	5700	112	11800
17	180	49	2600	81	5800	113	12000
18	200	50	2700	82	5900	114	12200
19	220	51	2800	83	6000	115	12400
20	240	52	2900	84	6200	116	12600
21	260	53	3000	85	6400	117	12800
22	280	54	3100	86	6600	118	13000
23	300	55	3200	87	6800	119	13200
24	350	56	3300	88	7000	120	13400
25	400	57	3400	89	7200	121	13600
26	450	58	3500	90	7400	122	13800
27	500	59	3600	91	7600	123	14000
28	550	60	3700	92	7800	124	14200
29	600	61	3800	93	8000	125	14400
30	700	62	3900	94	8200	126	14600
31	800	63	4000	95	8400	127	14800

**Table#15**  
Divide Frequency

Data	Value 1	Value 2	Data	Value 1	Value 2
0	32	1.2k	45	160	4.0k
1	32	1.6k	46	160	5.0k
2	32	2.0k	47	160	6.3k
3	32	2.5k	48	160	8.0k
4	32	3.2k	49	160	10.0k
5	32	4.0k	50	250	1.2k
6	32	5.0k	51	250	1.6k
7	32	6.3k	52	250	2.0k
8	32	8.0k	53	250	2.5k
9	32	10.0k	54	250	3.2k
10	63	1.2k	55	250	4.0k
11	63	1.6k	56	250	5.0k
12	63	2.0k	57	250	6.3k
13	63	2.5k	58	250	8.0k
14	63	3.2k	59	250	10.0k
15	63	4.0k	60	315	1.2k
16	63	5.0k	61	315	1.6k
17	63	6.3k	62	315	2.0k
18	63	8.0k	63	315	2.5k
19	63	10.0k	64	315	3.2k
20	80	1.2k	65	315	4.0k
21	80	1.6k	66	315	5.0k
22	80	2.0k	67	315	6.3k
23	80	2.5k	68	315	8.0k
24	80	3.2k	69	315	10.0k
25	80	4.0k	70	500	1.2k
26	80	5.0k	71	500	1.6k
27	80	6.3k	72	500	2.0k
28	80	8.0k	73	500	2.5k
29	80	10.0k	74	500	3.2k
30	125	1.2k	75	500	4.0k
31	125	1.6k	76	500	5.0k
32	125	2.0k	77	500	6.3k
33	125	2.5k	78	500	8.0k
34	125	3.2k	79	500	10.0k
35	125	4.0k	80	630	1.2k
36	125	5.0k	81	630	1.6k
37	125	6.3k	82	630	2.0k
38	125	8.0k	83	630	2.5k
39	125	10.0k	84	630	3.2k
40	160	1.2k	85	630	4.0k
41	160	1.6k	86	630	5.0k
42	160	2.0k	87	630	6.3k
43	160	2.5k	88	630	8.0k
44	160	3.2k	89	630	10.0k

**Table#17**  
Dynamic Attack Time

Data	Value	Data	Value	Data	Value	Data	Value
0	0.3	32	54	64	112	96	170
1	0.9	33	56	65	114	97	172
2	1.8	34	58	66	116	98	174
3	2.7	35	60	67	118	99	176
4	3.6	36	61	68	120	100	178
5	5.4	37	63	69	121	101	180
6	7.2	38	65	70	123	102	181
7	9.0	39	67	71	125	103	183
8	10	40	69	72	127	104	185
9	12	41	70	73	129	105	187
10	14	42	72	74	130	106	189
11	16	43	74	75	132	107	190
12	18	44	76	76	134	108	192
13	20	45	78	77	136	109	194
14	21	46	80	78	138	110	196
15	23	47	81	79	140	111	198
16	25	48	83	80	141	112	200
17	27	49	85	81	143	113	201
18	29	50	87	82	145	114	203
19	30	51	89	83	147	115	205
20	32	52	90	84	149	116	207
21	34	53	92	85	150	117	209
22	36	54	94	86	152	118	210
23	38	55	96	87	154	119	212
24	40	56	98	88	156	120	214

# Control List

## Assign A/B DESTINATION

No.	Display	Description
0	"off"	off
1	"EQLow-G"	MEQ Low Gain
2	"EQLow-F"	MEQ Low Frequency
3	"EQLow-Q"	MEQ Low Q
4	"EQLoM-G"	MEQ Low Mid Gain
5	"EQLoM-F"	MEQ Low Mid Frequency
6	"EQLoM-Q"	MEQ Low Mid Q
7	"EQMid-G"	MEQ Mid Gain
8	"EQMid-F"	MEQ Mid Frequency
9	"EQMid-Q"	MEQ Mid Q
10	"EQHiM-G"	MEQ High Mid Gain
11	"EQHiM-F"	MEQ High Mid Frequency
12	"EQHiM-Q"	MEQ High Mid Q
13	"EQHighG"	MEQ High Gain
14	"EQHighF"	MEQ High Frequency
15	"EQHighQ"	MEQ High Q
16	"REV-P1"	Reverb Parameter 1
:	:	:
25	"REV-P10"	Reverb Parameter 10
26	"REV-Rtn"	Reverb Return
27	"REV-Pan"	Reverb Pan
28	"CHO-P1"	Chorus Parameter 1
:	:	:
37	"CHO-P10"	Chorus Parameter 10
38	"CHO-Rtn"	Chorus Return
39	"CHO-Pan"	Chorus Pan
40	"Cho>Rev"	Send Chorus To Reverb
41	"Cho-Ctl"	Chorus Control
42	"ARP-Typ"	Arpeggio Type
43	"ARP-Unt"	Arpeggio Unit Multiply
44	"ARP-Vel"	Arpeggio Velocity Rate
45	"ARP-Gat"	Arpeggio Gate Time Rate
46	"Tempo"	Arpeggio/Sequencer Tempo
47	"AEG-Atk"	AEG Attack Time
48	"AEG-Dcy"	AEG Decay Time
49	"AEG-Sus"	AEG Sustain Level
50	"AEG-Rel"	AEG Release Time
47	"FEG-Atk"	FEG Attack Time
48	"FEG-Dcy"	FEG Decay Time
49	"FEG-Rel"	FEG Release Time
50	"FEG-Dpt"	FEG Depth
51	"Cutoff"	Cutoff Frequency
52	"Reso"	Resonance

## VOICE CONTROL SET DESTINATION

No.	Display	Description	Normal	Others
0	"off"	off	○	○
1	"Volume"	Voice Volume	○	○
2	"RevSend"	Reverb Send	○	○
3	"ChoSend"	Chorus Send	○	○
4	"INS1-P1"	Insertion Effect 1 Parameter 1	○	○
:	:	:	:	:
13	"INS1P10"	Insertion Effect 1 Parameter 10	○	○
14	"INS2-P1"	Insertion Effect 2 Parameter 1	○	○
:	:	:	:	:
29	"INS2P16"	Insertion Effect 2 Parameter 16	○	○
30	"CLFOSpd"	Common LFO Speed	○	×
31	"CLFO-D1"	Common LFO Depth1	○	×
32	"CLFO-D2"	Common LFO Depth2	○	×
33	"PorTime"	Portamento Time	○	×
34	"ELM-Lvl"	Element Level	○	×
35	"ELM-Pan"	Element Pan	○	×
36	"ELM-Dly"	Element Key On Delay	○	×
37	"ELFOSpd"	Element LFO Speed	○	×
38	"ELFO-PM"	Element LFO Pitch Modulation Depth	○	×
39	"ELFO-AM"	Element LFO Amplitude Modulation Depth	○	×
40	"ELFO-FM"	Element LFO Filter Modulation Depth	○	×
41	"PCH-Crs"	Element Pitch Coarse	○	×
42	"PCH-Fin"	Element Pitch Fine	○	×
43	"PEG-Dpt"	Element Pitch EG Depth	○	×
44	"PEG-Hld"	Element Pitch EG Hold Time	○	×
45	"PEG-Atk"	Element Pitch EG Attack Time	○	×
46	"PEG-D1"	Element Pitch EG Decay1 Time	○	×
47	"PEG-D2"	Element Pitch EG Decay2 Time	○	×
48	"PEG-Rel"	Element Pitch EG Release Time	○	×
49	"AEG-Atk"	Element Amplitude EG Attack Time	○	×
50	"AEG-D1"	Element Amplitude EG Decay1 Time	○	×
51	"AEG-D2"	Element Amplitude EG Decay2 Time	○	×
52	"AEG-Rel"	Element Amplitude EG Release Time	○	×
53	"FEG-Dpt"	Element Filter EG Depth	○	×
54	"FEG-Hld"	Element Filter EG Hold Time	○	×
55	"FEG-Atk"	Element Filter EG Attack Time	○	×
56	"FEG-D1"	Element Filter EG Decay1 Time	○	×
57	"FEG-D2"	Element Filter EG Decay2 Time	○	×
58	"FEG-Rel"	Element Filter EG Release Time	○	×
59	"FLT-Frq"	Element Filter Cutoff Frequency	○	×
60	"FLT-Rez"	Element Filter Resonance	○	×
61	"HPF-Frq"	Element HPF Cutoff Frequency	○	×
62	"CLFO-D3"	Common LFO Depth3	○	×

# Arpeggio Type List

## Preset1

No.	Name	Type
1	UpOct1	Sq
2	UpOct2	Sq
3	UpOct4	Sq
4	DownOct1	Sq
5	DownOct2	Sq
6	DownOct4	Sq
7	U/DAOct1	Sq
8	U/DAOct2	Sq
9	U/DAOct4	Sq
10	U/DBOct1	Sq
11	U/DBOct2	Sq
12	U/DBOct4	Sq
13	RndmOct1	Sq
14	RndmOct2	Sq
15	RndmOct4	Sq
16	Oct2Up	Sq
17	Oct4Up	Sq
18	UnisonUp	Sq
19	Up&Down1	Sq
20	Up&Down2	Sq
21	Up&Down4	Sq
22	Up&Alt1	Sq
23	Up&Rndm1	Sq
24	Up&Rndm2	Sq
25	Up&Rndm4	Sq
26	ChdAltB1	Sq
27	ChdAltB2	Sq
28	ChdAltB4	Sq
29	ChdRndm1	Sq
30	ChdRndm2	Sq
31	ChdRndm4	Sq
32	Techno A	Ph
33	Techno B	Ph
34	Techno C	Ph
35	DAHouse	Ph
36	SyncopaA	Ph
37	SyncopaB	Ph
38	SyncpEco	Ph
39	TekEchoA	Ph
40	TekEchoB	Ph
41	PulsLine	Ph
42	SeqS&H A	Ph
43	SeqS&H B	Ph
44	CleanGtA	Ph
45	CleanGtB	Ph
46	CleanGtC	Ph
47	CleanGtD	Ph
48	Pno16Bt	Ph
49	PnoLatin	Ph
50	GruvBass	Ph
51	Ocean	Ph
52	Orbit	Ph
53	X-SweepA	Ph
54	X-SweepB	Ph
55	X-SweepC	Ph
56	Lamb	Ph
57	Thips	Ph
58	Hardcore	Ph
59	Harmo	Ph
60	Ascorbic	Ph
61	Doves	Ph
62	Chodal	Ph
63	Simple	Ph
64	Waggle	Ph

No.	Name	Type
65	SuperArp	Ph
66	MuteArpA	Ph
67	MuteArpB	Ph
68	VelGruvA	Ph
69	VelGruvB	Ph
70	SpaceArp	Ph
71	MuteLine	Ph
72	StepLine	Ph
73	AcidLine	Ph
74	SplitArp	Ph
75	Step Seq	Ph
76	PolyArpA	Ph
77	PolyArpB	Ph
78	Ana Seq	Ph
79	Planet	Ph
80	Rosync	Ph
81	StrumArp	Ph
82	Guit1Arp	Ph
83	RolliArp	Ph
84	Guit2Arp	Ph
85	Guit3Arp	Ph
86	Guit4Arp	Ph
87	Harp Arp	Ph
88	BigBeatA	Dr
89	BigBeatB	Dr
90	BigBeatC	Dr
91	BigBeatD	Dr
92	Rock A	Dr
93	Rock B	Dr
94	Rock C	Dr
95	BigBeatE	Dr
96	BigBeatF	Dr
97	BigBeatG	Dr
98	BigBeatH	Dr
99	BigBeatI	Dr
100	BrkTrnce	Dr
101	House A	Dr
102	House B	Dr
103	House C	Dr
104	Garage	Dr
105	House D	Dr
106	House E	Dr
107	HipHop A	Dr
108	JazzHop	Dr
109	Abstract	Dr
110	LoBeat A	Dr
111	LoBeat B	Dr
112	LoBeat C	Dr
113	LoBeat D	Dr
114	LoBeat E	Dr
115	LoBeat F	Dr
116	DrumnBsA	Dr
117	DrumnBsB	Dr
118	Linear	Dr
119	08beat A	Sp
120	08beat B	Sp
121	08beat C	Sp
122	16beat A	Sp
123	16beat B	Sp
124	1Bar	Sp
125	1BarRndm	Sp
126	GateCutA	Ct
127	GateCutB	Ct
128	GateCutC	Ct

## Preset2

No.	Name	Type
1	Strum A	Ph
2	Strum B	Ph
3	Strum C	Ph
4	Strum D	Ph
5	Strum E	Ph
6	Strum F	Ph
7	Strum G	Ph
8	Strum H	Ph
9	Strum I	Ph
10	Strum J	Ph
11	LatinPHA	Ph
12	LatinPHB	Ph
13	LatinPHC	Ph
14	Funky A	Ph
15	Funky B	Ph
16	Funky C	Ph
17	Funky D	Ph
18	RockGtrA	Ph
19	RockGtrB	Ph
20	RockGtrC	Ph
21	Lick A	Ph
22	Lick B	Ph
23	Lick C	Ph
24	Lick D	Ph
25	Lick E	Ph
26	Lick F	Ph
27	News A	Ph
28	News B	Ph
29	Fugue	Ph
30	AcidBs A	Ph
31	AcidBs B	Ph
32	SlapBs A	Ph
33	SlapBs B	Ph
34	Walkin	Ph
35	Trill A	Ph
36	Trill B	Ph
37	Trill C	Ph
38	FlutterA	Ph
39	FlutterB	Ph
40	FlutterC	Ph
41	Flute A	Ph
42	Flute B	Ph
43	Flute C	Ph
44	Cresendo	Ph
45	MOD A	Ph
46	MOD B	Ph
47	MOD C	Ph
48	Pickin A	Ph
49	Pickin B	Ph
50	Pickin C	Ph
51	ArmDown	Ct
52	BendVib	Ct
53	BotDwVib	Ct
54	BotUpVib	Ct
55	CHVib	Ct
56	HamVib	Ct
57	PullVibA	Ct
58	PullVibB	Ct
59	SlideVib	Ct
60	Trill D	Ct
61	Trill E	Ct
62	UDCHVib	Ct
63	Vibra A	Ct
64	Vibra B	Ct

No.	Name	Type
65	FlipHopA	Dr
66	FlipHopB	Dr
67	FlipHopC	Dr
68	FlipHopD	Dr
69	GangstaA	Dr
70	GangstaB	Dr
71	GangstaC	Dr
72	GangstaD	Dr
73	i-Hop A	Dr
74	i-Hop B	Dr
75	i-Hop C	Dr
76	i-Hop D	Dr
77	R&BSmthA	Dr
78	R&BSmthB	Dr
79	R&BSmthC	Dr
80	R&BSmthD	Dr
81	House F	Dr
82	House G	Dr
83	House H	Dr
84	Funk A	Dr
85	Funk B	Dr
86	Funk C	Dr
87	Funk D	Dr
88	Gospel A	Dr
89	Gospel B	Dr
90	Bebop A	Dr
91	Bebop B	Dr
92	PopRckAA	Dr
93	PopRckAB	Dr
94	PopRckAC	Dr
95	PopRckAD	Dr
96	PopRckBA	Dr
97	PopRckBB	Dr
98	PopRckBC	Dr
99	PopRckBD	Dr
100	MondoRkA	Dr
101	MondoRkB	Dr
102	MondoRkC	Dr
103	MondoRkD	Dr
104	BalladAA	Dr
105	BalladAB	Dr
106	BalladAC	Dr
107	BalladAD	Dr
108	BalladBA	Dr
109	BalladBB	Dr
110	Roll A	Dr
111	Roll B	Dr
112	Roll C	Dr
113	Roll D	Dr
114	Latin A	Dr
115	Latin B	Dr
116	Latin C	Dr
117	Latin D	Dr
118	Latin E	Dr
119	DrumnBsC	Dr
120	DrumnBsD	Dr
121	DrumnBsE	Dr
122	DrumnBsF	Dr
123	DrumnBsG	Dr
124	EuroTekA	Dr
125	EuroTekB	Dr
126	EuroTekC	Dr
127	EuroTekD	Dr
128	EuroTekE	Dr

# MIDI Data Format

Many MIDI messages listed in the MIDI Data Format section are expressed in hexadecimal or binary numbers. Hexadecimal numbers may include the letter "H" as a suffix. The letter "n" indicates a certain whole number. The chart below lists the corresponding decimal number for each hexadecimal/binary number. For more information, refer to the Owner's Manual (page 118).

## SYNTHESIZER/SEQUENCER PART

### (1) TRANSMIT FLOW

MIDI<-	++[SW1]-----	NOTE ON/OFF	9nH
OUT			
		KEY'S AFTER TOUCH	AnH (Seq only)
		CONTROL CHANGE	
		MODULATION	BnH, 01H
		VOLUME	BnH, 07H
		PAN	BnH, 0AH
		SUSTAIN SWITCH	BnH, 40H
		FILTER RESONANCE	BnH, 47H
		EG RELEASE TIME	BnH, 48H
		EG ATTACK TIME	BnH, 49H
		FILTER CUTOFF FREQ	BnH, 4AH
		EG DECAY TIME	BnH, 4BH
		REVERB SEND	BnH, 5BH
		CHORUS SEND	BnH, 5DH
		ASSIGNABLE CONTROLLERS	BnH, (00H .. 5FH)
		SEQ REMOVT CONTROL	BnH, (00H .. 7FH)
	++[SW7]--	BANK SEL MSB	BnH, 00H
		BANK SEL LSB	BnH, 20H
		CHANNEL MODE MESSAGE (Seq only)	
		RESET ALL CONTROLLERS	BnH, 79H
		LOCAL CONTROL	BnH, 7AH
		OMNI MODE OFF	BnH, 7CH
		OMNI MODE ON	BnH, 7DH
		MONO MODE ON	BnH, 7EH
		POLY MODE ON	BnH, 7FH
	++[SW8]--	PROGRAM CHANGE	CnH
		CHANNEL AFTER TOUCH	DnH
		PITCH BEND CHANGE	EnH
++[SW4]-----		SYSTEM COMMON MESSAGE	
		SONG POSITION POINTER	F2H
++[SW4]-----		SYSTEM REALTIME MESSAGE	
		TIMING CLOCK	F8H
		START	FAH
		CONTINUE	FBH
		STOP	FCH
		ACTIVE SENSING	FEH
++[SW5]-----		SYSTEM EXCLUSIVE MESSAGE	
	++[SW6]--	<BULK DUMP>	F0H 43H 0nH 6BH bhH blH ahH amH alH ddH... ddH ccH F7H
	++[SW6]--	<PARAMETER CHANGE>	F0H 43H 1nH 6BH ahH amH alH ddH... ddH F7H
		SYSTEM EXCLUSIVE MESSAGE	
		IDENTITY REPLY	F0H 7EH 7FH 06H 02H 43H 00H 41H 05H 2AH 00H 00H 00H 7FH F7H

- [SW1] MIDI Transmit Channel  
In the Master mode: complies with Zone Transmit Channel.  
In the mode other than the Master: complies with Keyboard Transmit Channel.
- [SW2] MIDI Control Mode
- [SW4] Seq MIDI Control
- [SW5] MIDI Device Number  
When set to all, transmitted via 1.
- [SW6] In the Voice mode, only the Voice related data can be transmitted.  
In the Performance mode, only the Performance related data can be transmitted.  
The System data can be transmitted/recognized in any mode.
- [SW7] SYSTEM Bank Select Switch
- [SW8] SYSTEM Program Change Switch

### (2) RECEIVE FLOW

MIDI>--	++[SW10]-----	NOTE OFF	8nH
		NOTE ON/OFF	9nH
		CONTROL CHANGE	
		MODULATION	BnH, 01H
		PORTAMENTO TIME	BnH, 05H
		DATA ENTRY MSB	BnH, 06H
		DATA ENTRY LSB	BnH, 26H
		MAIN VOLUME	BnH, 07H
		PAN	BnH, 0AH
		EXPRESSION	BnH, 0BH
		SUSTAIN SWITCH	BnH, 40H
		PORTAMENTO SWITCH	BnH, 41H
		SOSTENUTO	BnH, 42H
		HARMONIC CONTENT	BnH, 47H
		EG RELEASE TIME	BnH, 48H
		EG ATTACK TIME	BnH, 49H
		BRIGHTNESS	BnH, 4AH
		EG DECAY TIME	BnH, 4BH
		EFFECT1 DEPTH	BnH, 5BH
		EFFECT3 DEPTH	BnH, 5DH
		DATA ENTRY INC	BnH, 60H
		DATA ENTRY DEC	BnH, 61H
		ALL SOUND OFF	BnH, 78H
		ASSIGNABLE CONTROLLER	BnH, (00H .. 5FH)
		NRPN	BnH, 62H, 63H *2
		RPN	
		PITCH BEND SENS.	BnH, 64H, 00H, 65H, 00H, 06H, mmH
		FINE TUNING	BnH, 64H, 01H, 65H, 00H, 06H, mmH, 26H, 11H *1
		COARSE TUNING	BnH, 64H, 02H, 65H, 00H, 06H, mmH *1
		RPN RESET	BnH, 64H, 7FH, 65H, 7FH
	++[SW2]--	EG SUSTAIN LEVEL	BnH, 1FH
	++[SW7]--	BANK SEL MSB	BnH, 00H
		BANK SEL LSB	BnH, 20H
		CHANNEL MODE MESSAGE	
		RESET ALL CONTROLLERS	BnH, 79H
		OMNI MODE OFF	BnH, 7CH
		OMNI MODE ON	BnH, 7DH
		MONO MODE ON	BnH, 7EH
		POLY MODE ON	BnH, 7FH
	++[SW8]--	PROGRAM CHANGE	CnH
		CHANNEL AFTER TOUCH	DnH
		PITCH BEND CHANGE	EnH
++[SW3]-----		SYSTEM REALTIME MESSAGE	
		TIMING CLOCK	F8H
++[SW4]-----		SYSTEM REALTIME MESSAGE	
		START	FAH
		CONTINUE	FBH
		STOP	FCH
		ACTIVE SENSING	FEH
++[SW5]-----		SYSTEM EXCLUSIVE MESSAGE	
		MIDI MASTER VOLUME	F0H 7FH 7FH 04H 01H 11H mmH F7H
	++[SW9]--	<BULK DUMP>	F0H 43H 0nH 6BH bhH blH ahH amH alH ddH... ddH ccH F7H *3
	++[SW6]--	<PARAMETER CHANGE>	F0H 43H 1nH 6BH ahH amH alH ddH... ddH F7H *3
	++[SW6]--	<BULK DUMP REQUEST>	F0H 43H 2nH 6BH ahH amH alH ddH... ddH F7H *3
	++[SW6]--	<PARAMETER REQUEST>	F0H 43H 3nH 6BH ahH amH alH F7H *3
	++[SW11]-	XG SYSTEM ON	F0H 43H 1nH 4CH 00H 00H 7EH 00H F7H
	++[SW11]-	GM MODE ON	F0H 7EH 7FH 09H 01H F7H
		SYSTEM EXCLUSIVE MESSAGE	
		IDENTITY REQUEST	F0H 7EH 0nH 06H 01H F7H

- [SW2] MIDI Control Mode
- [SW3] MIDI Sync (can be set to "Internal", or "MIDI")
- [SW4] Seq MIDI Control
- [SW5] MIDI Device Number  
When this is not set to off, the MIDI Master Volume can be recognized in any mode.
- [SW6] In the Voice mode, only the Voice related data can be transmitted.  
In the Performance mode, only the Performance related data can be transmitted.  
The System data can be transmitted/recognized in any mode.
- [SW7] SYSTEM Bank Select Switch
- [SW8] SYSTEM Program Change Switch (In the Voice mode, recognized only in the play mode.)
- [SW9] SYSTEM Bulk Protect and same as SW6.
- [SW10] MIDI Receive Channel  
In the Mixing mode: complies with Part Receive Channel and Part Receive Switch.  
In the other mode: complies with Basic Receive Channel.
- [SW11] SYSTEM Receive GM/XG On

\*1: Mixing Mode Only  
\*2: Available only for the Plug-in voices  
\*3: The messages of Plug-in Voice (MODEL ID = 64H) can be recognized/transmitted.

### (3) TRANSMIT/RECEIVE DATA

#### (3-1) CHANNEL VOICE MESSAGES

##### (3-1-1) NOTE OFF

STATUS 1000nnnn (8nH) n = 0-15 CHANNEL NUMBER  
 NOTE No. 0kkkkkkk k = 0 (C-2)-127 (G8)  
 VELOCITY 0vvvvvvv V: ignored

##### (3-1-2) NOTE ON/OFF

STATUS 1001nnnn (9nH) n = 0-15 CHANNEL NUMBER  
 NOTE NUMBER 0kkkkkkk k = 0 (C-2)-127 (G8)  
 VELOCITY NOTE ON 0vvvvvvv (v≠0)  
 NOTE OFF 0vvvvvvv (v=0)

##### (3-1-3) CONTROL CHANGE

STATUS 1011nnnn (BnH) n = 0-15 CHANNEL NUMBER  
 CONTROL NUMBER 0ccccccc  
 CONTROL VALUE 0vvvvvvv

\* TRANSMITTED CONTROL NUMBER

c = 0	BANK SEL MSB	v = 0 - 127	*3
c = 32	BANK SEL LSB	v = 0 - 127	*3
c = 1	MODULATION	v = 0 - 127	
c = 7	MAIN VOLUME	v = 0 - 127	
c = 10	PAN	v = 0 - 127	
c = 11	EXPRESSION	v = 0 - 127	
c = 64	SUSTAIN SWITCH	v = 0, 127	
c = 71	FILTER RESONANCE	v = 0:-64 - 64:0 - 127:+63	
c = 72	EG RELEASE TIME	v = 0:-64 - 64:0 - 127:+63	
c = 73	EG ATTACK TIME	v = 0:-64 - 64:0 - 127:+63	
c = 74	FILTER CUTOFF FREQ	v = 0:-64 - 64:0 - 127:+63	
c = 75	EG DECAY TIME	v = 0:-64 - 64:0 - 127:+63	
c = 91	REVERB SEND	v = 0, 127	
c = 93	CHORUS SEND	v = 0, 127	
c = 0..95	ASSIGNABLE CONTROLLERS	v = 0 - 127	*6

The Sequencer Part will play back all recorded control change messages.

\* RECEIVED CONTROL NUMBER

c = 0	BANK SEL MSB	v = 0 - 127	*3
c = 32	BANK SEL LSB	v = 0 - 127	*3
c = 1	MODULATION	v = 0 - 127	
c = 5	PORTAMENTO TIME	v = 0 - 127	*2
c = 6	DATA ENTRY MSB	v = 0 - 127	*1
c = 38	DATA ENTRY LSB	v = 0 - 127	*1
c = 7	MAIN VOLUME	v = 0 - 127	
c = 10	PAN	v = 0 - 127	
c = 11	EXPRESSION	v = 0 - 127	
c = 31	EG SUSTAIN LEVEL	v = 0:-64 - 64:0 - 127:+63	*2,*5
c = 64	SUSTAIN SWITCH	v = 0-63:OFF, 64-127:ON	*2
c = 65	PORTAMENTO SWITCH	v = 0-63:OFF, 64-127:ON	*2
c = 66	SOSTENUTO	v = 0-63:OFF, 64-127:ON	*2
c = 71	HARMONIC CONTENT	v = 0:-64 - 64:0 - 127:+63	
c = 72	EG RELEASE TIME	v = 0:-64 - 64:0 - 127:+63	*2
c = 73	EG ATTACK TIME	v = 0:-64 - 64:0 - 127:+63	
c = 74	BRIGHTNESS	v = 0:-64 - 64:0 - 127:+63	
c = 75	EG DECAY TIME	v = 0:-64 - 64:0 - 127:+63	
c = 91	EFFECT1 DEPTH	v = 0 - 127	
c = 93	EFFECT3 DEPTH	v = 0 - 127	
c = 96	DATA ENTRY INC	v = 127	*1
c = 97	DATA ENTRY DEC	v = 127	*1
c = 0..95	ASSIGNABLE CONTROLLER	v = 0 - 127	*6
c = 0..95	ARPEGGIO SW	v = 0-63:OFF, 64-127:ON	*6
c = 0..95	ARPEGGIO HOLD	v = 0-63:OFF, 64-127:ON	*6

\*1 Used only when a value is set using RPN.

\*2 Invalid with Drum Voices.

\*3 Relation between BANK CHANGE and PROGRAM is as follows:

CATEGORY	MSB	LSB	PROGRAM No.
GM Voice	0	0	0..127 (1..128)
GM Drum Voice	127	0	0..1 (1..2)
Normal Voice Preset 1	63	0	0..127 (1..128)
Preset 2	63	1	0..127 (1..128)
Preset 3	63	2	0..127 (1..128)
User	63	8	0..127 (1..128)
Drum Voice Preset	63	32	0..47 (1..48)
User	63	40	0..15 (1..16)
Plug-in Voice User 1	63	24	0..63 (1..64)
User 2	63	25	0..63 (1..64)
User 3	63	26	0..63 (1..64)
Performance User	63	64	0..127 (1..128)
Plug-in Voice Preset 1 (Slot1)	63	70	0..63 (1..64) *4
Preset 2 (Slot1)	63	71	0..63 (1..64) *4
Preset 3 (Slot1)	63	72	0..63 (1..64) *4
Preset 1 (Slot2)	63	73	0..63 (1..64) *4
Preset 2 (Slot2)	63	74	0..63 (1..64) *4
Preset 3 (Slot2)	63	75	0..63 (1..64) *4
Preset 1 (Slot3)	63	76	0..63 (1..64) *4
Preset 2 (Slot3)	63	77	0..63 (1..64) *4
Preset 3 (Slot3)	63	78	0..63 (1..64) *4

\*4 Can be selected only when the corresponding Plug-in board has been installed.

\*5 Transmitted/received only when MODE2 is selected in CONTROL CHANGE MODE.

\*6 The default CONTROL NUMBERS of ASSIGNABLE CONTROLLER are as follows:

BREATH CONTROLLER	2
FOOT CONTROLLER	4
Assign1	16
Assign2	17
Assign A	18
Assign B	19
FOOT SWITCH	88
ARPEGGIO HOLD	89
ARPEGGIO SWITCH	90

PORTAMENTO TIME sets the time it takes for the pitch to reach the next note played when PORTAMENTO SWITCH is set to on.

PAN position relatively changes according to the preset value for each voice.

EFFECT1 DEPTH controls reverb send level.

EFFECT3 DEPTH controls chorus send level.

HARMONIC CONTENT adjusts the resonance preset for each voice.

Setting a value adds to or subtracts from the center value, 64, since it is an offset parameter.

The larger the value more resonant sound will be produced. The effective range may be narrower than the range you can designate depending on the selected voice.

The parameters, EG ATTACK TIME, EG DECAY TIME, EG SUSTAIN LEVEL, EG RELEASE TIME adjust the envelopes preset for each voice.

Setting these values add to or subtract from the center value, 64, since these are offset parameters.

BRIGHTNESS adjusts the cutoff frequency preset for each voice.

Setting a value adds to or subtracts from the center value, 64, since it is an offset parameter.

The smaller the value the cutoff frequency will be lowered. The effective range may be narrower than the range you can designate depending on the selected voice.

Bank Select will be actually executed when the Program Change message is received.

Bank Select and Program Change numbers that are not supported by Yamaha will be ignored, but transmitted to the Plug-in board.

##### (3-1-4) PROGRAM CHANGE

STATUS 1100nnnn (CnH) n = 0-15 CHANNEL NUMBER  
 PROGRAM NUMBER 0pppppppp = 0-127

##### (3-1-5) CHANNEL AFTER TOUCH

STATUS 1101nnnn (DnH) n = 0-15 CHANNEL NUMBER  
 VALUE 0vvvvvvv v = 0-127 AFTER TOUCH VALUE

##### (3-1-6) PITCH BEND CHANGE

STATUS 1110nnnn (EnH) n = 0-15 CHANNEL NUMBER  
 LSB 0vvvvvvv PITCH BEND CHANGE LSB  
 MSB 0vvvvvvv PITCH BEND CHANGE MSB  
 Transmitted with a resolution of 7 bits.

#### (3-2) CHANNEL MODE MESSAGES

STATUS 1011nnnn (BnH) n = 0-15 CHANNEL NUMBER  
 CONTROL NUMBER 0ccccccc c = CONTROL NUMBER  
 CONTROL VALUE 0vvvvvvv v = DATA VALUE

##### (3-2-1) ALL SOUND OFF (CONTROL NUMBER = 78H, DATA VALUE = 0)

All the sounds currently played including the channel messages such as note-on and hold-on in a certain channel are muted when receiving this message.

##### (3-2-2) RESET ALL CONTROLLERS (CONTROL NUMBER = 79H, DATA VALUE = 0)

Resets the values set for the following controllers.

PITCH BEND CHANGE	0 (center)
CHANNEL AFTER TOUCH	0 (minimum)
MODULATION	0 (minimum)
EXPRESSION	127 (maximum)
BREATH CONTROLLER	127 (maximum)
FOOT CONTROLLER	127 (maximum)
Assign 1	0 (center)
Assign 2	0 (center)
SUSTAIN SWITCH	0 (off)
SOSTENUTO SWITCH	0 (off)
RPN	Not assigned; No change

Doesn't reset the following data:

PROGRAM CHANGE, BANK SELECT MSB/LSB, VOLUME, PAN, HARMONIC CONTENT, SUSTAIN LEVEL, RELEASE TIME, ATTACK TIME, DECAY TIME, BRIGHTNESS, EFFECT SEND LEVEL 1, EFFECT SEND LEVEL 3, PORTAMENTO SWITCH, PITCH BEND SENSITIVITY, FINE TUNING, COARSE TUNING

##### (3-2-3) ALL NOTE OFF (CONTROL NUMBER = 7BH, DATA VALUE = 0)

All the notes currently set to on in certain channel(s) are muted when receiving this message. However, if Sustain or Sostenuto is on, notes will continue sounding until these are turned off.

##### (3-2-4) OMNI MODE OFF (CONTROL NUMBER = 7CH, DATA VALUE = 0)

Performs the same function as when receiving ALL NOTES OFF.

Sets VOICE RECEIVE CHANNEL to "OMNI OFF," channel 1.

##### (3-2-5) OMNI MODE ON (CONTROL NUMBER = 7DH, DATA VALUE = 0)

Performs the same function as when receiving ALL NOTES OFF.

Sets VOICE RECEIVE CHANNEL to "OMNI ON."

##### (3-2-6) MONO (CONTROL NUMBER = 7EH, DATA VALUE = 0.16)

Performs the same function as when receiving ALL SOUNDS OFF. The channel will be within 0 through 16, the channel will be Mode4 (m = 1).

In the Voice mode, the mode can be Mode2 (m = 1) according to VOICE RECEIVE CHANNEL.

##### (3-2-7) POLY (CONTROL NUMBER = 7FH, DATA VALUE = 0)

Performs the same function as when receiving ALL SOUNDS OFF. The channel will be Mode3.

In the Voice mode, the mode can be Mode1 according to VOICE RECEIVE CHANNEL.

**(3-3) REGISTERED PARAMETER NUMBER**

STATUS	1011nnnn (8nH)	n = 0-15 CHANNEL NUMBER
LSB	01100100 (64H)	
RPN LSB	0ppppppp	p = RPN LSB (Refer to the table as shown below)
MSB	01100101 (65H)	
RPN MSB	0qggggggq	q = RPN MSB (Refer to the table as shown below)
DATA ENTRY MSB	00000110 (06H)	
DATA VALUE	0mmmmmm	m = Data Value
DATA ENTRY LSB	00100110 (26H)	
DATA VALUE	01111111	l = Data Value

First, designate the parameter using RPN MSB/LSB numbers. Then, set its value with data entry MSB/LSB.

RPN LSB MSB	D. ENTRY MSB LSB	PARAMETER NAME	DATA RANGE
00H 00H	mmH ---	PITCH BEND SENSITIVITY	00H - 18H (0 - 24 semitones)
01H 00H	mmH 11H	MASTER FINE TUNE	{mmH, 11H} = {00H, 00H} - {40H, 00H} - {7FH, 7FH} (-8192*100/8192) - 0 - (+8192*100/8192)
02H 00H	mmH ---	MASTER COARSE TUNE	28H - 40H - 58H (-24 - 0 - +24 semitones)
7FH 7FH	--- ---	RPN RESET	

RPN numbers will be left not designated.  
The internal values are not affected.

**(3-4) NON-REGISTERED PARAMETER NUMBER**

There are no applicable parameters.  
These are transmitted to the Plug-in board.

**(3-5) SYSTEM REAL TIME MESSAGES**

**(3-5-1) ACTIVE SENSING**

STATUS	11111110 (FEH)
--------	----------------

Transmitted at every 200 msec.

Once this code is received, the instrument starts sensing. When no status nor data is received for over approximately 350 ms, MIDI receiving buffer will be cleared, and the sounds currently played and the sustain switch are forcibly turned off. In this case, each control data will be reset to a certain value.

**(3-6) SYSTEM EXCLUSIVE MESSAGE**

**(3-6-1) UNIVERSAL NON REALTIME MESSAGE**

**(3-6-1-1) GENERAL MIDI MODE ON**

FOH 7EH 7FH 09H 01H F7H
-------------------------

Received only when SYSTEM Receive GM/XG on is set to on in PERFORMANCE MODE. The Part values will be reset according to the SYSTEM Internal Part settings.

**(3-6-1-2) IDENTITY REQUEST (Receive only)**

FOH 7EH 0nH 06H 01H F7H ("n" = Device No. However, this instrument receives under "omni.")

**(3-6-1-3) IDENTITY REPLY (Transmit only)**

FOH 7EH 7FH 06H 02H 43H 00H 41H ddH ddH 00H 00H 00H 7FH F7H
---

dd: Device Number Code  
S90: 05 2A

**(3-6-2) UNIVERSAL REALTIME MESSAGE**

**(3-6-2-1) MIDI MASTER VOLUME**

FOH 7FH 7FH 04H 01H 11H mmH F7H
---------------------------------

Sets the MASTER VOLUME value.  
The value "mm" is used to set the master volume (the value "l" should be ignored).

**(3-6-3) PARAMETER CHANGE**

**(3-6-3-1) XG SYSTEM ON**

11110000	F0	Exclusive status
01000011	43	YAMAHA ID
0001nnnn	1n	Device Number
01001100	4C	Model ID
0aaaaaaa	00	Address High
0aaaaaaa	00	Address Mid
0aaaaaaa	7E	Address Low
0	0	Data
11110111	F7	End of Exclusive

Received only when SYSTEM Receive GM/XG on is set to on in PERFORMANCE MODE. The Part values will be reset according to the SYSTEM Internal Part settings.

Be aware that executing this message takes ca. 170ms and that, therefore, a certain interval before executing the following message is needed.

**(3-6-3-2) NATIVE PARAMETER CHANGE, MODE CHANGE**

11110000	F0	Exclusive status
01000011	43	YAMAHA ID
0001nnnn	1n	Device Number
01101011	6B	Model ID
0aaaaaaa	aaaaaaa	Address High
0aaaaaaa	aaaaaaa	Address Mid
0aaaaaaa	aaaaaaa	Address Low
0ddddd	ddddd	Data
11110111	F7	End of Exclusive

For parameters with data size of 2 or more, the appropriate number of data bytes will be transmitted.  
See the following MIDI Data Table for Address and Byte Count.

Always received no matter which device number is selected, in the case of REMOTE SWITCH.

**(3-6-4) BULK DUMP**

11110000	F0	Exclusive status
01000011	43	YAMAHA ID
0000nnnn	0n	Device Number
01101011	6B	Model ID
0bbbbbbb	bbbbbbb	Byte Count
0bbbbbbb	bbbbbbb	Byte Count
0aaaaaaa	aaaaaaa	Address High
0aaaaaaa	aaaaaaa	Address Mid
0aaaaaaa	aaaaaaa	Address Low
0	0	Data
0ccccccc	ccccccc	Check-sum
11110111	F7	End of Exclusive

See the following MIDI Data Table for Address and Byte Count.

The Check sum is the value that results in a value of 0 for the lower 7 bits when the Byte Count, Start Address, Data and Check sum itself are added.

**(3-6-5) DUMP REQUEST**

11110000	F0	Exclusive status
01000011	43	YAMAHA ID
0010nnnn	2n	Device Number
01101011	6B	Model ID
0aaaaaaa	aaaaaaa	Address High
0aaaaaaa	aaaaaaa	Address Mid
0aaaaaaa	aaaaaaa	Address Low
11110111	F7	End of Exclusive

See the following MIDI Data Table for Address and Byte Count.

**(3-6-6) PARAMETER REQUEST**

11110000	F0	Exclusive status
01000011	43	YAMAHA ID
0011nnnn	3n	Device Number
01101011	6B	Model ID
0aaaaaaa	aaaaaaa	Address High
0aaaaaaa	aaaaaaa	Address Mid
0aaaaaaa	aaaaaaa	Address Low
11110111	F7	End of Exclusive

See the following MIDI Data Table for Address and Byte Count.

**(4) SYSTEM OVERVIEW (Keyboard, Sequencer and Tone Generator)**

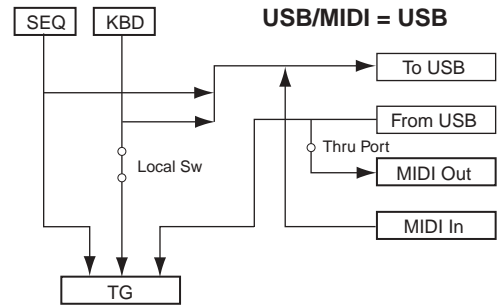
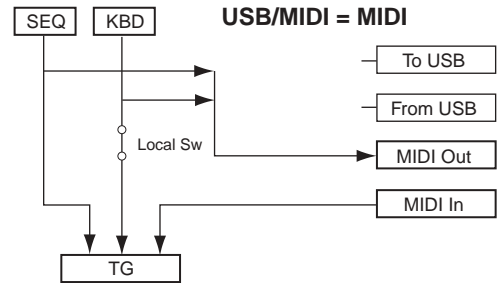

The optional mLAN board can be installed to the S90.

Although three types of note on/note off data, received via MIDI, played by the internal sequencer and played on the keyboard will be distinguished, the other controllers (channel messages) equally affect the entire notes.

ALL SOUND OFF clears all the sounds in the specific channel(s) played by both the keyboard and the data via MIDI.  
ALL NOTES OFF received via MIDI clears the sounds in the specific channel(s) played via MIDI.



# MIDI Data Table

## Bank Select

Available Bank Select/Program Change

MSB (HEX)	LSB (HEX)	Program No.	Type	Memory (Bank)	
0	00	0 - 127	Normal Voice	GM Voice	
127	7F	0	Drum Voice	GM Drum	
63	3F	0 - 127	Normal Voice	Preset 1	
		1 01		Preset 2	
		2 02		Preset 3	
		8 08	0 - 127	User	
		32 20	0 - 47	Drum Voice	Preset
		40 28	0 - 15		User
		24 18	0 - 63	Plug-in Voice	User 1(Slot1)
		25 19	0 - 63		User 2(Slot2)
		26 1A	0 - 63		User 3(Slot3)
		70 46	0 - 63		Preset 1(Slot1)
		71 47	0 - 63		Preset 2(Slot1)
		72 48	0 - 63		Preset 3(Slot1)
		73 49	0 - 63		Preset 1(Slot2)
		74 4A	0 - 63		Preset 2(Slot2)
		75 4B	0 - 63		Preset 3(Slot2)
		76 4C	0 - 63		Preset 1(Slot3)
		77 4D	0 - 63	Preset 2(Slot3)	
		78 4E	0 - 63	Preset 3(Slot3)	
Depending on the installed Plug-in Board.				Plug-in Direct	
63	3F	64 40	Performance	User(Internal)	

When only the Program Change is received after entering any of the mode, the corresponding voice in the currently selected Type/Memory is called up.  
 The Master number and the Performance/Sequence Play/Voice mode can be changed only via the Parameter Change.  
 In the Performance mode, the Part Voice cannot be changed via the Program Change.

<Table 1>  
Parameter Base Address

Parameter Block	Top Address			Description	
	H	M	L		
SYSTEM	00	00	00	System	
	00	10	00	Plug-in Board Native System	
	00	20	00	Master EQ for Voice	
	01	00	00	Seq Remote Mode Common	
	02	00	00	Seq Remote Mode Track1 Message	
	:	:	:	:	
	02	0F	00	Seq Remote Mode Track16 Message	
MODE CHANGE	0A	00	00	Mode Change	
BULK CONTROL	0E	00	00	Header	
	0F	00	00	Footer	
MULTIPLE BULK CONTROL	10	00	00	Header	
	11	00	00	Footer	
MASTER KEYBOARD	33	00	00	Common	
	32	00	00	Zone1	
	32	03	00	Zone4	
PERFORMANCE COMMON	30	00	00	Performance Common	
PERFORMANCE PART	31	00	00	Part1	
	:	:	:	:	
	31	03	00	Part4	
	31	60	00	Plug-in 1 Part	
	31	61	00	Plug-in 2 Part	
	31	62	00	Plug-in 3 Part	
	40	00	00	Common1	
40	00	40	Common2		
NORMAL VOICE COMMON	40	01	00	Reverb	
	40	02	00	Chorus	
	40	03	00	Insertion 1	
	40	04	00	Insertion 2	
	40	05	00	Controller	
	40	06	00	LFO	
	40	70	00	Extra	
	NORMAL VOICE ELEMENT GROUP1	41	ee	00	ee : Element No.
	NORMAL VOICE ELEMENT GROUP2	42	ee	00	ee : Element No.
	NORMAL VOICE ELEMENT GROUP3	43	ee	00	ee : Element No.
NORMAL VOICE ELEMENT GROUP4	44	ee	00	ee : Element No.	
DRUM COMMON	46	00	00	Common1	
	46	00	40	Common2	
	46	01	00	Reverb	
	46	02	00	Chorus	
	46	03	00	Insertion 1	
	46	04	00	Insertion 2	
	46	05	00	Controller	
	46	70	00	Extra	
DRUM ELEMENT GROUP1	47	ee	00	ee : Element No.	
DRUM ELEMENT GROUP2	48	ee	00	ee : Element No.	
DRUM ELEMENT GROUP3	49	ee	00	ee : Element No.	
DRUM ELEMENT GROUP4	4A	ee	00	ee : Element No.	
VOICE PLUG-IN	4C	00	00	Common	
	4C	01	00	Reverb	
	4C	02	00	Chorus	
	4C	03	00	Insertion 1	
	4C	04	00	Insertion 2	
	4C	05	00	Controller	
	4C	10	00	Plug-in XG Part	
	4C	20	00	Native	
	4C	70	00	Extra	
	Mix	36	00	00	Mix Common
37		00	00	Part1	
:		:	:	:	
37		0F	00	Part16	
37		60	00	Plug-in 1 Part	
37		61	00	Plug-in 2 Part	
37	62	00	Plug-in 3 Part		

## <Table 2> Bulk Dump Block

"Top Address" indicates the top address of each block designated by bulk dump operation.  
 "Byte Count" indicates the data size contained in each block designated by bulk dump operation.  
 To execute 1 Performance/1 Voice bulk dump request, designate its corresponding Bulk Header address.  
 After the reception of the Bulk Dump (USER memory) or System Parameter Change from the Voice Editor etc., you need to write to Flash ROM by using the Multiple Bulk Control footer messages.

For the information about "mm" and "nn" shown in the following list, refer to MIDI PARAMETER CHANGE TABLE (BULK CONTROL) below.

Parameter Block	Description	Byte Count		Top Address				
		Dec	Hex	H	M	L		
SYSTEM	System	60	003C	00	00	00		
	Plug-in Board Native System	48	0030	00	10	00		
	Master EQ (for Voice Mode)	20	0014	00	20	00		
	Seq Remote Mode Common	19	0013	01	00	00		
	Seq Remote Tr1 Message	57	0039	02	00	00		
	:	16 Blocks	:	:	:	:		
	Seq Remote Tr16 Message	57	0039	02	0F	00		
MASTER KEYBOARD	Bulk Header	0	00	0E	mm	nn		
	Common	19	0013	33	00	00		
	Zone1	16	0010	32	00	00		
	:	4 Blocks	:	:	:	:		
	Bulk Footer	0	00	0F	mm	nn		
PERFORMANCE	Bulk Header	0	00	0E	mm	nn		
	COMMON	Common	88	0058	30	00	00	
		Reverb	24	0018	30	01	00	
		Chorus	25	0019	30	02	00	
		Variation	38	0026	30	03	00	
		Master EQ	20	0014	30	10	00	
		Native (for InsEF Plug-in)	68	0044	30	20	00	
		:	4 Blocks	:	:	:	:	
	PART	Part1	45	002D	31	00	00	
		:	16 Blocks	:	:	:		
		Part16	45	002D	37	0F	00	
	PLUG-IN PART	Plug-in 1 Part	45	002D	31	60	00	
		:	3 Blocks	:	:	:		
		Plug-in 3 Part	45	002D	31	62	00	
		Bulk Footer	0	00	0F	mm	nn	
	VOICE (NORMAL)	Bulk Header	0	00	0E	mm	nn	
		COMMON	Extra	66	0042	40	70	00
			Common1	15	000F	40	00	00
			Common2	4	0004	40	00	40
			Reverb	24	0018	40	01	00
Chorus			25	0019	40	02	00	
Insertion 1(S)			22	0016	40	03	00	
Insertion 2(L)			34	0022	40	04	00	
Controller			30	001E	40	05	00	
LFO			37	0025	40	06	00	
ELEMENT 1			Oscillator	28	001C	41	00	00
		Amplitude	30	001E	41	00	20	
		Pitch	29	001D	42	00	00	
		Filter	50	0032	43	00	00	
		EQ	8	0008	44	00	00	
		LFO	7	0007	44	00	40	
		ELEMENT 2	Oscillator	28	001C	41	01	00
			Amplitude	30	001E	41	01	20
			Pitch	29	001D	42	01	00
			Filter	50	0032	43	01	00
EQ	8		0008	44	01	00		
LFO	7		0007	44	01	40		
ELEMENT 3	Oscillator		28	001C	41	02	00	
	Amplitude		30	001E	41	02	20	
	Pitch		29	001D	42	02	00	
	Filter		50	0032	43	02	00	
	EQ	8	0008	44	02	00		
	LFO	7	0007	44	02	40		
	ELEMENT 4	Oscillator	28	001C	41	03	00	
		Amplitude	30	001E	41	03	20	
		Pitch	29	001D	42	03	00	
		Filter	50	0032	43	03	00	
EQ		8	0008	44	03	00		
LFO		7	0007	44	03	40		
Bulk Footer		0	00	0F	mm	nn		
VOICE (DRUM)		Bulk Header	0	00	0E	mm	nn	
		COMMON	Extra	66	0042	46	70	00
			Common1	8	0008	46	00	00
	Common2		4	0004	46	00	40	
	Reverb		24	0018	46	01	00	
	Chorus		25	0019	46	02	00	
	Insertion 1(S)		22	0016	46	03	00	
	Insertion 2(L)		34	0022	46	04	00	
	Controller		30	001E	46	05	00	
	KEY C 0		Oscillator	19	0013	47	00	00
			Amplitude	12	000C	47	00	20
		Pitch	3	0003	48	00	00	
		Filter	8	0008	49	00	00	
		EQ	8	0008	4A	00	00	
		:	73 Blocks	:	:	:	:	

Parameter Block	Description	Byte Count		Top Address		
		Dec	Hex	H	M	L
KEY C 6	Oscillator	19	0013	47	48	00
	Amplitude	12	000C	47	48	20
	Pitch	3	0003	48	48	00
	Filter	8	0008	49	48	00
	EQ	8	0008	4A	48	00
	Bulk Footer	0	00	0F	mm	nn

Parameter Block	Description	Byte Count		Top Address			
		Dec	Hex	H	M	L	
VOICE (PLUG-IN)	Bulk Header	0	00	0E	mm	nn	
	COMMON	Extra	66	0042	4C	70	00
		Common	13	000D	4C	00	00
		Reverb	24	0018	4C	01	00
		Chorus	25	0019	4C	02	00
		Insertion 1(S)	22	0016	4C	03	00
		Insertion 2(L)	34	0022	4C	04	00
		Controller	10	000A	4C	05	00
		Plug-in XG Part	35	0023	4C	10	00
		Native	68	0044	4C	20	00
		Bulk Footer	0	00	0F	mm	nn
	* The messages of Plug-in Voice (MODEL ID = 64H) can be recognized/transmitted.						

Parameter Block	Description	Byte Count		Top Address				
		Dec	Hex	H	M	L		
MIX	Bulk Header	0	00	0E	mm	nn		
	COMMON	Common	88	0058	36	00	00	
		Reverb	24	0018	36	01	00	
		Chorus	25	0019	36	02	00	
		Variation	38	0026	36	03	00	
		Master EQ	20	0014	36	10	00	
		Native (for InsEF Plug-in)	68	0044	36	20	00	
		PART	Part1	45	002D	37	00	00
			:	16 Blocks	:	:	:	
			Part16	45	002D	37	0F	00
		PLUG-IN PART	Plug-in 1 Part	45	002D	37	60	00
	:		3 Blocks	:	:	:		
	Plug-in 3 Part		45	002D	37	62	00	
Bulk Footer	0	00	0F	mm	nn			

## <Table 3-1> MIDI PARAMETER CHANGE TABLE (Mode Change)

Address	Size	Data Range (HEX)	Parameter Name	Description	Notes
0A 00 00	1	00 - 7F	MASTER NUMBER SELECT	0-127	
	01	00 - 04	MODE CHANGE	0:Voice, 1:Performance, 2:Reserved, 3:SeqPlay (Mix), 4:Master	

## <Table 3-2> MIDI PARAMETER CHANGE TABLE (BULK CONTROL)

Address	Size	Data Range (HEX)	Parameter Name	Description	Notes
0E 08 nn	1	-	Bulk Header	Normal Voice INT (nn = 0 - 127)	
09 nn	1	-		reserved	
0F nn	1	-		Normal Voice Edit Buffer (nn = 0)	
18 nn	1	-		Plug-in Voice PLG1 (nn = 0 - 63)	
19 nn	1	-		Plug-in Voice PLG2 (nn = 0 - 63)	
1A nn	1	-		Plug-in Voice PLG3 (nn = 0 - 63)	
1F nn	1	-		Plug-in Voice Edit Buffer (nn = 0)	
28 nn	1	-		Drum Voice INT (nn = 0 - 15)	
29 nn	1	-		reserved	
2F nn	1	-		Drum Voice Edit Buffer (nn = 0)	
40 nn	1	-		Performance INT (nn = 0 - 127)	
41 nn	1	-		reserved	
4F nn	1	-		Performance Edit Buffer (nn = 0)	
5F nn	1	-		Mix Edit Buffer (nn = 0)	
68 nn	1	-		reserved	
6F nn	1	-		reserved	
70 nn	1	-		Master INT (nn = 0 - 127)	
7F nn	1	-		Master Edit Buffer (nn = 0)	
0F 08 nn	1	-	Bulk Footer	Normal Voice INT (nn = 0 - 127)	
09 nn	1	-		reserved	
0F nn	1	-		Normal Voice Edit Buffer (nn = 0)	
18 nn	1	-		Plug-in Voice PLG1 (nn = 0 - 63)	
19 nn	1	-		Plug-in Voice PLG2 (nn = 0 - 63)	
1A nn	1	-		Plug-in Voice PLG3 (nn = 0 - 63)	
1F nn	1	-		Plug-in Voice Edit Buffer (nn = 0)	
28 nn	1	-		Drum Voice INT (nn = 0 - 15)	
29 nn	1	-		reserved	
2F nn	1	-		Drum Voice Edit Buffer (nn = 0)	
40 nn	1	-		Performance INT (nn = 0 - 127)	
41 nn	1	-		reserved	
4F nn	1	-		Performance Edit Buffer (nn = 0)	
5F nn	1	-		Mix Edit Buffer (nn = 0)	
68 nn	1	-		reserved	
6F nn	1	-		reserved	
70 nn	1	-		Master INT (nn = 0 - 127)	
7F nn	1	-		Master Edit Buffer (nn = 0)	

<Table 4>  
MIDI PARAMETER CHANGE TABLE (SYSTEM)

Address	Size	Data Range (HEX)	Parameter Name	Description	Notes
00 00 00	1	00 - 7F	Master Volume	0 - 127	MIDI Master Volume
01	1	28 - 58	Master Note Shift	-24 - +24[semitones]	
02	4	00 - 0F 00 - 0F 00 - 0F 00 - 0F	Master Tune	-102.4 - +102.3[cent] 1st bit 3-0 → bit 15-12 2nd bit 3-0 → bit 11-8 3rd bit 3-0 → bit 7-4 4th bit 3-0 → bit 3-0	MIDI Master Tuning
06	1	00 - 01	Controller Reset	hold, reset	
07	1	35 - 4B	Master Transpose	-11 - +11[semitones]	
08	1	3D - 43	Master Octave Shift	-3 - +3	
09	1	00 - 01	Local Switch	off, on	
0A	1	00 - 10, 7F	Basic Receive Channel	1 - 16, omni, off	
0B	1	00 - 0F, 7F	Keyboard Transmit Channel	1 - 16, off	
0C	1	00	reserved		
0D	1	00 - 01	reserved		
0E	1	00 - 03	STEREO L&R OUTPUT GAIN	00:0dB, 01:+6dB, 02:+12dB, 03:+18dB	
0F	1	00 - 03	INDIVIDUAL OUT 1 OUTPUT GAIN	00:0dB, 01:+6dB, 02:+12dB, 03:+18dB	
10	1	00 - 03	INDIVIDUAL OUT 2 OUTPUT GAIN	00:0dB, 01:+6dB, 02:+12dB, 03:+18dB	
11	1	00 - 03	BC Curve (for TG)	thru, soft, hard, wide	
12	1	00 - 04	Keyboard Velocity Curve	norm, soft, hard, wide, fixed	
13	1	01 - 7F	Keyboard Fixed Velocity	1 - 127	
14	1	00 - 01	Receive GM/XG On for Multi Part PB	off, on	
15	1	00 - 01	Receive/Transmit Bank Select	off, on	
16	1	00 - 01	Receive/Transmit Program Change	off, on	
17	1	00 - 01	MIDI Control Mode	mode 1, mode 2	
18	1	00 - 07	Thru Port for USB	1 - 8	
19	1	00 - 02	MIDI IN/OUT	MIDI, USB, mLAN	
1A	1	00 - 07	Effect Bypass for System Effect	bit0: Reverb, bit1: Chorus, bit2: Variation	
1B	1	01	reserved		
1C	1	00 - 03	Effect Bypass for Insertion Effect	bit0: Internal, bit1: Plug-in Board	
1D	1	00 - 01	reserved		
1E	1	00 - 01	AutoLoad Switch	off, on	
1F	1	00 - 05	Power on Mode	Performance, Voice (INT), Voice (PRE1), GM, Master	
20	1	00	reserved		
21	1	00 - 02	Single Part Plug-in Board Port Assign	1, 2, 3	Port 1 in any other mode
22	1	00 - 02	Multi Part Plug-in Board Port Assign	1, 2, 3	Port 1 in any other mode
23	1	00 - 01	reserved		
24	1	00 - 01	A/D Source	analog, mLAN	
25	1	00 - 01	Analog Input Gain	mic, line	
26	1	00	reserved		
27	1	00 - 01	reserved		
28	1	00 - 01	reserved		
29	1	00	reserved		
2A	1	00 - 34	Assign A Destination	off, 1 - 52	
2B	1	00 - 34	Assign B Destination	off, 1 - 52	
2C	1	00	reserved		
2D	1	00 - 5F	Assign A Control Number	off, 1 - 95	
2E	1	00 - 5F	Assign B Control Number	off, 1 - 95	
2F	1	14	reserved		
30	1	01	reserved		
31	1	00 - 65	FS Assign	off, 1 - 95, ArpSw, ArpHold, Play/Stop, PCInc, PCDec, OctaveReset	
32	1	00 - 5F	ARP Switch Control Number	off, 1 - 95	
33	1	00 - 5F	ARP Hold Control Number	off, 1 - 95	
34	1	00 - 01	ARP MIDI Out Switch	off, on	for Voice Mode
35	1	00 - 0F	ARP MIDI Out Channel	1 - 16	:
36	1	00 - 5F	Assign1 Control Number	off, 1 - 95	:
37	1	00 - 5F	Assign2 Control Number	off, 1 - 95	:
38	1	00 - 5F	BC Control Number	off, 1 - 95	:
39	1	00 - 5F	FC2 Control Number	off, 1 - 95	:
3A	1	00 - 5F	FC1 Control Number	off, 1 - 95	:
3B	1	00	reserved		

TOTAL SIZE = 60 3C (HEX)

00 10 00	16	00 - 7F	Plug-in 1 Native System Parameter	depends on Plug-in Board	
10 10 00	16	00 - 7F	Plug-in 2 Native System Parameter	depends on Plug-in Board	
20 10 00	16	00 - 7F	Plug-in 3 Native System Parameter	depends on Plug-in Board	

TOTAL SIZE = 48 30 (HEX)

Address	Size	Data Range (HEX)	Parameter Name	Description	Notes
00 20 00	1	34 - 4C	EQ Gain1	-12 - +12[dB]	for Voice Mode
01	1	04 - 28	EQ Frequency1	32 - 2000[Hz]	:
02	1	01 - 78	EQ Q1	0.1 - 12.0	:
03	1	00 - 01	EQ Shape1	shelv, peak	:
04	1	34 - 4C	EQ Gain2	-12 - +12[dB]	:
05	1	0E - 36	EQ Frequency2	100 - 10.0[kHz]	:
06	1	01 - 78	EQ Q2	0.1 - 12.0	:
	1	01	reserved		:
08	1	34 - 4C	EQ Gain3	-12 - +12[dB]	:
09	1	0E - 36	EQ Frequency3	100 - 10.0[kHz]	:
0A	1	01 - 78	EQ Q3	0.1 - 12.0	:
	1		NOT USED		:
0C	1	34 - 4C	EQ Gain4	-12 - +12[dB]	:
0D	1	0E - 36	EQ Frequency4	100 - 10.0[kHz]	:
0E	1	01 - 78	EQ Q4	0.1 - 12.0	:
	1		NOT USED		:
10	1	34 - 4C	EQ Gain5	-12 - +12[dB]	:
11	1	1C - 3A	EQ Frequency5	0.5 - 16.0[kHz]	:
12	1	01 - 78	EQ Q5	0.1 - 12.0	:
13	1	00 - 01	EQ Shape5	shelv, peak	:

TOTAL SIZE = 20 14 (HEX)

01 00 00	1	00 - 04	Seq Remote Mode Template	0:Logic, 1:Cubase, 2:SONAR, 3:ProTools, 4:SQ01	
01 00 01	1	00 - 03	Seq Remote Mode Port Number	off, 1, 2, 3	
01 00 02	1	00 - 04	Seq Remote Slider Function Select	Group1, 2, 3, 4, Slider (Track1-4/5-8/9-12/13-16)	
01 00 03	1	00 - 7F	Seq Remote Mode Top Switch Message	0 - 127	
01 00 04	1	00 - 0F, 7F	Seq Remote Mode Top Switch Channel	1 - 16, off	
01 00 05	1	00 - 7F	Seq Remote Mode << Switch Message	0 - 127	
01 00 06	1	00 - 7F	Seq Remote Mode << Switch on Value	0 - 127	
01 00 07	1	00 - 7F	Seq Remote Mode << Switch off Value	0 - 127	
01 00 08	1	00 - 0F, 7F	Seq Remote Mode << Switch Channel	1 - 16, off	
01 00 09	1	00 - 7F	Seq Remote Mode >> Switch Message	0 - 127	
01 00 0A	1	00 - 7F	Seq Remote Mode >> Switch on Value	0 - 127	
01 00 0B	1	00 - 7F	Seq Remote Mode >> Switch off Value	0 - 127	
01 00 0C	1	00 - 0F, 7F	Seq Remote Mode >> Switch Channel	1 - 16, off	
01 00 0D	1	00 - 7F	Seq Remote Mode Rec Switch Message	0 - 127	
01 00 0E	1	00 - 0F, 7F	Seq Remote Mode Rec Switch Channel	1 - 16, off	
01 00 0F	1	00 - 7F	Seq Remote Mode Stop Switch Message	0 - 127	
01 00 10	1	00 - 0F, 7F	Seq Remote Mode Stop Switch Channel	1 - 16, off	
01 00 11	1	00 - 7F	Seq Remote Mode Play Switch Message	0 - 127	
01 00 12	1	00 - 0F, 7F	Seq Remote Mode Play Switch Channel	1 - 16, off	

TOTAL SIZE = 19 13 (HEX)

02 tt 00	1	00 - 7F	Seq Remote Mode Track Select Switch Message	0 - 127	
02 tt 01	1	00 - 0F, 7F	Seq Remote Mode Track Select Switch Channel	1 - 16, off	
02 tt 02	1	00 - 7F	Seq Remote Mode Track Mute Switch Message	0 - 127	
02 tt 03	1	00 - 7F	Seq Remote Mode Track Mute on Value	0 - 127	
02 tt 04	1	00 - 7F	Seq Remote Mode Track Mute off Value	0 - 127	
02 tt 05	1	00 - 0F, 7F	Seq Remote Mode Track Mute Switch Channel	1 - 16, off	
02 tt 06	1	00 - 7F	Seq Remote Mode Slider Message	0 - 127	
02 tt 07	1	00 - 0F, 7F	Seq Remote Mode Slider Channel	1 - 16, off	
02 tt 08	1	00 - 32	Seq Remote Mode Slider Name	0 - 50	
02 tt 09	1	00 - 7F	Seq Remote Mode Group1 CS1 Message	0 - 127	
02 tt 0A	1	00 - 0F, 7F	Seq Remote Mode Group1 CS1 Channel	1 - 16, off	
02 tt 0B	1	00 - 32	Seq Remote Mode Group1 CS1 Name	---, Vol, Pan, Fx1, ...	
02 tt 0C	1	00 - 7F	Seq Remote Mode Group1 CS2 Message	0 - 127	
02 tt 0D	1	00 - 0F, 7F	Seq Remote Mode Group1 CS2 Channel	1 - 16, off	
02 tt 0E	1	00 - 32	Seq Remote Mode Group1 CS2 Name	---, Vol, Pan, Fx1, ...	
02 tt 0F	1	00 - 7F	Seq Remote Mode Group1 CS3 Message	0 - 127	
02 tt 10	1	00 - 0F, 7F	Seq Remote Mode Group1 CS3 Channel	1 - 16, off	
02 tt 11	1	00 - 32	Seq Remote Mode Group1 CS3 Name	---, Vol, Pan, Fx1, ...	

Address	Size	Data Range (HEX)	Parameter Name	Description	Notes
02 tt 12 1	00 - 7F	Seq Remote Mode Group1 CS4 Message	0 - 127		
02 tt 13 1	00 - 0F, 7F	Seq Remote Mode Group1 CS4 Channel	1 - 16, off		
02 tt 14 1	00 - 32	Seq Remote Mode Group1 CS4 Name	---, Vol, Pan, Fx1, ...		
02 tt 15 1	00 - 7F	Seq Remote Mode Group2 CS1 Message	0 - 127		
02 tt 16 1	00 - 0F, 7F	Seq Remote Mode Group2 CS1 Channel	1 - 16, off		
02 tt 17 1	00 - 32	Seq Remote Mode Group2 CS1 Name	---, Vol, Pan, Fx1, ...		
02 tt 18 1	00 - 7F	Seq Remote Mode Group2 CS2 Message	0 - 127		
02 tt 19 1	00 - 0F, 7F	Seq Remote Mode Group2 CS2 Channel	1 - 16, off		
02 tt 1A 1	00 - 32	Seq Remote Mode Group2 CS2 Name	---, Vol, Pan, Fx1, ...		
02 tt 1B 1	00 - 7F	Seq Remote Mode Group2 CS3 Message	0 - 127		
02 tt 1C 1	00 - 0F, 7F	Seq Remote Mode Group2 CS3 Channel	1 - 16, off		
02 tt 1D 1	00 - 32	Seq Remote Mode Group2 CS3 Name	---, Vol, Pan, Fx1, ...		
02 tt 1E 1	00 - 7F	Seq Remote Mode Group2 CS4 Message	0 - 127		
02 tt 1F 1	00 - 0F, 7F	Seq Remote Mode Group2 CS4 Channel	1 - 16, off		
02 tt 20 1	00 - 32	Seq Remote Mode Group2 CS4 Name	---, Vol, Pan, Fx1, ...		
02 tt 21 1	00 - 7F	Seq Remote Mode Group3 CS1 Message	0 - 127		
02 tt 22 1	00 - 0F, 7F	Seq Remote Mode Group3 CS1 Channel	1 - 16, off		
02 tt 23 1	00 - 32	Seq Remote Mode Group3 CS1 Name	---, Vol, Pan, Fx1, ...		
02 tt 24 1	00 - 7F	Seq Remote Mode Group3 CS2 Message	0 - 127		
02 tt 25 1	00 - 0F, 7F	Seq Remote Mode Group3 CS2 Channel	1 - 16, off		
02 tt 26 1	00 - 32	Seq Remote Mode Group3 CS2 Name	---, Vol, Pan, Fx1, ...		
02 tt 27 1	00 - 7F	Seq Remote Mode Group3 CS3 Message	0 - 127		
02 tt 28 1	00 - 0F, 7F	Seq Remote Mode Group3 CS3 Channel	1 - 16, off		
02 tt 29 1	00 - 32	Seq Remote Mode Group3 CS3 Name	---, Vol, Pan, Fx1, ...		
02 tt 2A 1	00 - 7F	Seq Remote Mode Group3 CS4 Message	0 - 127		
02 tt 2B 1	00 - 0F, 7F	Seq Remote Mode Group3 CS4 Channel	1 - 16, off		
02 tt 2C 1	00 - 32	Seq Remote Mode Group3 CS4 Name	---, Vol, Pan, Fx1, ...		
02 tt 2D 1	00 - 7F	Seq Remote Mode Group4 CS1 Message	0 - 127		
02 tt 2E 1	00 - 0F, 7F	Seq Remote Mode Group4 CS1 Channel	1 - 16, off		
02 tt 2F 1	00 - 32	Seq Remote Mode Group4 CS1 Name	---, Vol, Pan, Fx1, ...		
02 tt 30 1	00 - 7F	Seq Remote Mode Group4 CS2 Message	0 - 127		
02 tt 31 1	00 - 0F, 7F	Seq Remote Mode Group4 CS2 Channel	1 - 16, off		
02 tt 32 1	00 - 32	Seq Remote Mode Group4 CS2 Name	---, Vol, Pan, Fx1, ...		
02 tt 33 1	00 - 7F	Seq Remote Mode Group4 CS3 Message	0 - 127		
02 tt 34 1	00 - 0F, 7F	Seq Remote Mode Group4 CS3 Channel	1 - 16, off		
02 tt 35 1	00 - 32	Seq Remote Mode Group4 CS3 Name	---, Vol, Pan, Fx1, ...		
02 tt 36 1	00 - 7F	Seq Remote Mode Group4 CS4 Message	0 - 127		
02 tt 37 1	00 - 0F, 7F	Seq Remote Mode Group4 CS4 Channel	1 - 16, off		
02 tt 38 1	00 - 32	Seq Remote Mode Group4 CS4 Name	---, Vol, Pan, Fx1, ...		

TOTAL SIZE = 57 39 (HEX)

tt = Track number  
00 - 0F Track 1 - 16

<Table 5>  
MIDI PARAMETER CHANGE TABLE (MASTER)

Address	Size	Data Range (HEX)	Parameter Name	Description	Notes
33 00 00 1	20 - 7E	Master Name1	32..126(ASCII)		
33 00 01 1	20 - 7E	Master Name2	32..126(ASCII)		
33 00 02 1	20 - 7E	Master Name3	32..126(ASCII)		
33 00 03 1	20 - 7E	Master Name4	32..126(ASCII)		
33 00 04 1	20 - 7E	Master Name5	32..126(ASCII)		
33 00 05 1	20 - 7E	Master Name6	32..126(ASCII)		
33 00 06 1	20 - 7E	Master Name7	32..126(ASCII)		
33 00 07 1	20 - 7E	Master Name8	32..126(ASCII)		
33 00 08 1	20 - 7E	Master Name9	32..126(ASCII)		
33 00 09 1	20 - 7E	Master Name10	32..126(ASCII)		
33 00 0A 1	00	reserved			
33 00 0B 1	00	reserved			
33 00 0C 1	00	reserved			
33 00 0D 1	00 - 03	Mode Change	0=Voice, 1=Performance, 2=Reserved, 3=SeqPlay (Mix)		
33 00 0E 1	00 - 7F	Bank MSB for Voice/Perf Mode	0..127		
33 00 0F 1	00 - 7F	Bank LSB for Voice/Perf Mode	0..127		
33 00 10 1	00 - 7F	Program Number	1..128		
33 00 11 1	00 - 01	Zone on/off for Performance Mode	off, on		
33 00 12 1	00 - 05	Slider Function Select (CONTROL FUNCTION)	0=Pan&Send, 1=Zone, 2=Assign, 3=MeqOffset, 4=Zone, 5=Volume		

TOTAL SIZE = 19 13 (HEX)

Address	Size	Data Range (HEX)	Parameter Name	Description	Notes
32 nn 00 1	00 - 3F	Transmit Channel, MIDI/TG Switch	bit0-3: Ch1..16 bit4: MIDI off,on bit5: TG off,on		
32 nn 01 1	3D - 43	Transpose (Octave)	-3..+3		
32 nn 02 1	35 - 4B	Transpose (Semitone)	-11..+11(semitones)		
32 nn 03 1	00 - 7F	Note Limit Low	C-2..G8		
32 nn 04 1	00 - 7F	Note Limit High	C-2..G8		
32 nn 05 1	00 - 03	Transmit Bank Select for TG	bit0: off, on Bank Select		
32 nn 06 1	7F	Transmit Program Change for TG	bit1: off, on Program Change		
32 nn 07 1	00 - 7F	reserved			
32 nn 08 1	00 - 7F	MIDI Volume	0..127		
32 nn 09 1	00 - 7F	MIDI Pan	0..127		
32 nn 0A 1	00 - 7F	MIDI Bank MSB	0..127		
32 nn 0B 1	00 - 7F	MIDI Bank LSB	0..127		
32 nn 0C 1	00 - 7F	MIDI Program Number	1..128		
32 nn 0D 1	00 - 7F	Transmit Volume/Expression	bit0: off, on Volume/Expression		Ctrl#7,11
32 nn 0E 1	00 - 7F	Transmit Pan	bit1: off, on Pan		
32 nn 0F 1	00 - 7F	Transmit Sustain	bit2: off, on Sustain		
32 nn 10 1	00 - 7F	Transmit Bank Select for MIDI	bit3: off, on Bank Select		
32 nn 11 1	00 - 7F	Transmit Program Change for MIDI	bit4: off, on Program Change		
32 nn 12 1	00 - 7F	Transmit AT	bit5: off, on AT		
32 nn 13 1	00 - 7F	Transmit PB	bit6: off, on PB		
32 nn 14 1	00 - 7F	Transmit FC2	bit0: off, on FC2		
32 nn 15 1	00 - 7F	Transmit FS	bit1: off, on FS		
32 nn 16 1	00 - 7F	Transmit FC1	bit2: off, on FC1		
32 nn 17 1	00 - 7F	Transmit BC	bit3: off, on BC		
32 nn 18 1	00 - 7F	Transmit MW	bit4: off, on MW		
32 nn 19 1	00 - 7F	Transmit Assignable Slider	bit5: off, on Assignable Slider		
32 nn 1A 1	00 - 7F	reserved	bit6		
32 nn 1B 1	00 - 5F	Control Slider Control Number	off, 1 - 95		
32 nn 1C 1	00 - 5F	reserved			

TOTAL SIZE = 16 10 (HEX)

nn = zone number 00 - 03

<Table 6>  
MIDI PARAMETER CHANGE TABLE  
(PERFORMANCE COMMON)

Address	Size	Data Range (HEX)	Parameter Name	Description	Notes
30 00 00 1	20 - 7E	Performance Name1	32..126(ASCII)		
30 00 01 1	20 - 7E	Performance Name2	32..126(ASCII)		
30 00 02 1	20 - 7E	Performance Name3	32..126(ASCII)		
30 00 03 1	20 - 7E	Performance Name4	32..126(ASCII)		
30 00 04 1	20 - 7E	Performance Name5	32..126(ASCII)		
30 00 05 1	20 - 7E	Performance Name6	32..126(ASCII)		
30 00 06 1	20 - 7E	Performance Name7	32..126(ASCII)		
30 00 07 1	20 - 7E	Performance Name8	32..126(ASCII)		
30 00 08 1	20 - 7E	Performance Name9	32..126(ASCII)		
30 00 09 1	20 - 7E	Performance Name10	32..126(ASCII)		
30 00 0A 1	00	reserved			
30 00 0B 1	00	reserved			
30 00 0C 1	00 - 10	Performance Category(Main)	0..16(--Co)		Ap, Kb, Or, Gt, Ba, St, Br, Rp, Ld, Pd, Sc,Cp,Dr,Se,Me,Co
30 00 0D 1	00 - 03	Performance Category(Sub)	0..3(--Sub1..Sub3)		depends on Main Category
30 00 0E 1	00	reserved			
30 00 0F 1	00	reserved			
30 00 10 1	10	reserved			
30 00 11 1	00 - 01	ARP MIDI Out Switch	off, on		
30 00 12 1	00 - 10	ARP MIDI Transmit Channel	1..16, kbd-ch		
30 00 13 1	00 - 02	QED ARP Type Bank	pre1, pre2, user		

Address	Size	Data Range (HEX)	Parameter Name	Description	Notes
30 00 14	1	00 - 7F	QED ARP Type	UpOct1 - GateCut3	
30 00 15	1	00 - 01	ARP Switch	off, on	
30 00 16	1	00 - 02	ARP Hold	sync-off, off, on	
30 00 17	1	00 - 06	ARP Unit Multiply	50%, 66%, 75%, 100%, 133%, 150%, 200%	
30 00 18	1	00 - 7F	ARP Note Limit Low	C-2..G8	
30 00 19	1	00 - 7F	ARP Note Limit High	C-2..G8	
30 00 1A	1	01 - 7F	ARP Velocity Limit Low	1 - 127	
30 00 1B	1	01 - 7F	ARP Velocity Limit High	1 - 127	
30 00 1C	1	00 - 02	ARP Key Mode	sort, thru, direct	
30 00 1D	1	00 - 01	ARP Vel Mode	original,thru	
30 00 1E	2	0000 - 00C8	ARP Velocity Rate MSB ARP Velocity Rate LSB	0...200%	
30 00 20	2	0000 - 00C8	ARP Gate Time Rate MSB ARP Gate Time Rate LSB	0...200%	
30 00 22	2	0001 - 012C	QED ARP Tempo MSB QED ARP Tempo LSB	1..300	
30 00 24	1	00 - 04	CS Function Select (CONTROL FUNCTION)	0=Pan&Send, 1= Tone, 2=Assign, 3=MeqOffset, 4=Volume	
30 00 25	1	01 - 7F	Pan	L63...C...R63	
30 00 26	1	00 - 7F	Chorus Control	-64..+63	
30 00 27	1	00 - 7F	QED Decay Time	-64..+63	
30 00 28	1	00 - 7F	QED Sustain Level	-64..+63	
30 00 29	1	00 - 7F	QED FEG Attack Time	-64..+63	
30 00 2A	1	00 - 7F	QED FEG Decay Time	-64..+63	
30 00 2B	1	00 - 7F	QED FEG Release Time	-64..+63	
30 00 2C	1	40	reserved		
30 00 2D	1	00 - 7F	QED FEG Depth	-64..+63	
30 00 2E	1	00 - 7F	ASA	-64..+63	
30 00 2F	1	00 - 7F	ASB	-64..+63	
30 00 30	1	40	reserved		
30 00 31	1	00 - 7F	EQ Low Gain	-64..+63	
30 00 32	1	00 - 7F	EQ Low Mid Gain	-64..+63	
30 00 33	1	00 - 7F	EQ High Mid Gain	-64..+63	
30 00 34	1	00 - 7F	EQ High Gain	-64..+63	
30 00 35	1	00 - 7F	Scene 1 Assign1	-64..+63	
30 00 36	1	00 - 7F	Scene 1 Assign2	-64..+63	
30 00 37	1	00 - 7F	Scene 1 Cutoff Frequency	-64..+63	
30 00 38	1	00 - 7F	Scene 1 Resonance	-64..+63	
30 00 39	1	00 - 7F	Scene 1 Attack Time	-64..+63	
30 00 3A	1	00 - 7F	Scene 1 Release Time	-64..+63	
30 00 3B	1	40	reserved		
30 00 3C	1	40	reserved		
30 00 3D	1	40	reserved		
30 00 3E	1	40	reserved		
30 00 3F	1	40	reserved		
30 00 40	1	40	reserved		
30 00 41	1	40	reserved		
30 00 42	1	00 - 7F	Volume	0..127	
30 00 43	1	00 - 7F	QED Portamento Time	-64..+63	
30 00 44	1	00 - 01	QED Portamento Switch	off, on	
30 00 45	1	00 - 7F	Reverb Send	0..127	
30 00 46	1	00 - 7F	Chorus Send	0..127	
30 00 47	1	00	reserved		
30 00 48	1	00 - 5F	Assign1 Control Number	off, 1 - 95	
30 00 49	1	00 - 5F	Assign2 Control Number	off, 1 - 95	
30 00 4A	1	00 - 5F	BC Control Number	off, 1 - 95	
30 00 4B	1	00 - 5F	FC2 Control Number	off, 1 - 95	
30 00 4C	1	00 - 5F	FC1 Control Number	off, 1 - 95	
30 00 4D	1	00 - 7F	Voice Insertion Effect Part	0 - 3: Part1...4 96 - 98: PB Part1, 2, 3 127: off	
30 00 4E	1		reserved		
30 00 4F	1	00 - 7F	InsEF Plug-in Part	0 - 3: Part1...4 64: PartAD 97 - 98: PB Part2, 3 127: off	
30 00 50	1	00 - 03	A/D Input Mode	L mono, R mono, L+R mono, stereo	Fixed at "mono" when using Analog Input
30 00 51	1	00 - 7F	A/D Part Volume	0 - 127	
30 00 52	1	01 - 7F	A/D Part Pan	L63 - C - R63	
30 00 53	1	00 - 7F	A/D Part Reverb Send	0 - 127	
30 00 54	1	00 - 7F	A/D Part Chorus Send	0 - 127	
30 00 55	1	00 - 7F	A/D Part Variation Send	0 - 127	
30 00 56	1	00 - 7F	A/D Part Dry Level	0 - 127	
30 00 57	1	00 - 71	A/D Part Output Select	0: L&R 8: asnL&R, 10: asn1&2, 11: asn3&4 64 - 65: asnL, asnR, 68-71 :asn1-4	

TOTAL SIZE = 88 58 (HEX)

Address	Size	Data Range (HEX)	Parameter Name	Description	Notes
30 01 00	2	00 - 7F	Reverb Type MSB	Refer to Effect Parameter List	
		00 - 7F	Reverb Type LSB		
30 01 02	2	00 - 7F	Reverb Parameter 1 MSB		-
		00 - 7F	Reverb Parameter 1 LSB		
30 01 04	2	00 - 7F	Reverb Parameter 2 MSB		-
		00 - 7F	Reverb Parameter 2 LSB		
30 01 06	2	00 - 7F	Reverb Parameter 3 MSB	Refer to Effect Parameter List	
		00 - 7F	Reverb Parameter 3 LSB		
30 01 08	2	00 - 7F	Reverb Parameter 4 MSB		-
		00 - 7F	Reverb Parameter 4 LSB		
30 01 0A	2	00 - 7F	Reverb Parameter 5 MSB		-
		00 - 7F	Reverb Parameter 5 LSB		
30 01 0C	2	00 - 7F	Reverb Parameter 6 MSB		-
		00 - 7F	Reverb Parameter 6 LSB		
30 01 0E	2	00 - 7F	Reverb Parameter 7 MSB		-
		00 - 7F	Reverb Parameter 7 LSB		
30 01 10	2	00 - 7F	Reverb Parameter 8 MSB		-
		00 - 7F	Reverb Parameter 8 LSB		
30 01 12	2	00 - 7F	Reverb Parameter 9 MSB		-
		00 - 7F	Reverb Parameter 9 LSB		
30 01 14	2	00 - 7F	Reverb Parameter 10 MSB		-
		00 - 7F	Reverb Parameter 10 LSB		
30 01 16	1	00 - 7F	Reverb Return	-->dB...0dB...+6dB(0...96...127)	
30 01 17	1	01 - 7F	Reverb Pan	L63...C...R63	

TOTAL SIZE = 24 18 (HEX)

30 02 00	2	00 - 7F	Chorus Type MSB	Refer to Effect Parameter List	
		00 - 7F	Chorus Type LSB		
30 02 02	2	00 - 7F	Chorus Parameter 1 MSB		-
		00 - 7F	Chorus Parameter 1 LSB		
30 02 04	2	00 - 7F	Chorus Parameter 2 MSB		-
		00 - 7F	Chorus Parameter 2 LSB		
30 02 06	2	00 - 7F	Chorus Parameter 3 MSB		-
		00 - 7F	Chorus Parameter 3 LSB		
30 02 08	2	00 - 7F	Chorus Parameter 4 MSB		-
		00 - 7F	Chorus Parameter 4 LSB		
30 02 0A	2	00 - 7F	Chorus Parameter 5 MSB		-
		00 - 7F	Chorus Parameter 5 LSB		
30 02 0C	2	00 - 7F	Chorus Parameter 6 MSB		-
		00 - 7F	Chorus Parameter 6 LSB		
30 02 0E	2	00 - 7F	Chorus Parameter 7 MSB		-
		00 - 7F	Chorus Parameter 7 LSB		
30 02 10	2	00 - 7F	Chorus Parameter 8 MSB		-
		00 - 7F	Chorus Parameter 8 LSB		
30 02 12	2	00 - 7F	Chorus Parameter 9 MSB		-
		00 - 7F	Chorus Parameter 9 LSB		
30 02 14	2	00 - 7F	Chorus Parameter 10 MSB		-
		00 - 7F	Chorus Parameter 10 LSB		
30 02 16	1	00 - 7F	Chorus Return	-->dB...0dB...+6dB(0...96...127)	
30 02 17	1	01 - 7F	Chorus Pan	L63...C...R63	
30 02 18	1	00 - 7F	Send Chorus To Reverb	-->dB...0dB(0...127)	

TOTAL SIZE = 25 19 (HEX)

30 03 00	2	00 - 7F	Variation Type MSB (for Performance)	Refer to Effect Parameter List	
		00 - 7F	Variation Type LSB		
30 03 02	2	00 - 7F	Variation Parameter1 MSB		-
		00 - 7F	Variation Parameter1 LSB		
30 03 04	2	00 - 7F	Variation Parameter2 MSB		-
		00 - 7F	Variation Parameter2 LSB		
30 03 06	2	00 - 7F	Variation Parameter3 MSB		-
		00 - 7F	Variation Parameter3 LSB		
30 03 08	2	00 - 7F	Variation Parameter4 MSB		-
		00 - 7F	Variation Parameter4 LSB		
30 03 0A	2	00 - 7F	Variation Parameter5 MSB		-
		00 - 7F	Variation Parameter5 LSB		
30 03 0C	2	00 - 7F	Variation Parameter6 MSB		-
		00 - 7F	Variation Parameter6 LSB		
30 03 0E	2	00 - 7F	Variation Parameter7 MSB		-
		00 - 7F	Variation Parameter7 LSB		
30 03 10	2	00 - 7F	Variation Parameter8 MSB		-
		00 - 7F	Variation Parameter8 LSB		
30 03 12	2	00 - 7F	Variation Parameter9 MSB		-
		00 - 7F	Variation Parameter9 LSB		
30 03 14	2	00 - 7F	Variation Parameter10 MSB		-
		00 - 7F	Variation Parameter10 LSB		
30 03 16	2	00 - 7F	Variation Parameter11 MSB		-
		00 - 7F	Variation Parameter11 LSB		
30 03 18	2	00 - 7F	Variation Parameter12 MSB		-
		00 - 7F	Variation Parameter12 LSB		
30 03 1A	2	00 - 7F	Variation Parameter13 MSB		-
		00 - 7F	Variation Parameter13 LSB		
30 03 1C	2	00 - 7F	Variation Parameter14 MSB		-
		00 - 7F	Variation Parameter14 LSB		
30 03 1E	2	00 - 7F	Variation Parameter15 MSB		-
		00 - 7F	Variation Parameter15 LSB		
30 03 20	2	00 - 7F	Variation Parameter16 MSB		-
		00 - 7F	Variation Parameter16 LSB		
30 03 22	1	00 - 7F	Variation Return	-->dB...0dB...+6dB(0...96...127)	
30 03 23	1	01 - 7F	Variation Pan	L63...C...R63	
30 03 24	1	00 - 7F	Send Variation To Reverb	-->dB...0dB(0...127)	
30 03 25	1	00 - 7F	Send Variation To Chorus	-->dB...0dB(0...127)	

TOTAL SIZE = 38 26 (HEX)

Address	Size	Data Range (HEX)	Parameter Name	Description	Notes
30 10 00	1	34 - 4C	EQ Gain1	-12 - +12[dB]	
30 10 01	1	04 - 28	EQ Frequency1	32 - 2000[Hz]	
30 10 02	1	01 - 78	EQ Q1	0.1 - 12.0	
30 10 03	1	00 - 01	EQ Shape1	shelv,peak	
30 10 04	1	34 - 4C	EQ Gain2	-12 - +12[dB]	
30 10 05	1	0E - 36	EQ Frequency2	100 - 10.0[kHz]	
30 10 06	1	01 - 78	EQ Q2	0.1 - 12.0	
30 10 07	1	01	reserved		
30 10 08	1	34 - 4C	EQ Gain3	-12 - +12[dB]	
30 10 09	1	0E - 36	EQ Frequency3	100 - 10.0[kHz]	
30 10 0A	1	01 - 78	EQ Q3	0.1 - 12.0	
	1		Not Used		
30 10 0C	1	34 - 4C	EQ Gain4	-12 - +12[dB]	
30 10 0D	1	0E - 36	EQ Frequency4	100 - 10.0[kHz]	
30 10 0E	1	01 - 78	EQ Q4	0.1 - 12.0	
	1		Not Used		
30 10 10	1	34 - 4C	EQ Gain5	-12 - +12[dB]	
30 10 11	1	1C - 3A	EQ Frequency5	0.5 - 16.0[kHz]	
30 10 12	1	01 - 78	EQ Q5	0.1 - 12.0	
30 10 13	1	00 - 01	EQ Shape5	shelv,peak	
TOTAL SIZE = 20 14 (HEX)					

30 20 00	16	00 - 7F	Plug-in Board Native System Parameter	(for InsEF Plug-in)	
30 20 10	48	00 - 7F	Plug-in Board Native Parameter	(for InsEF Plug-in)	
30 20 40	3	00 - 7F	Plug-in Board Type MSB	(for InsEF Plug-in)	
		00 - 7F	Plug-in Board Type LSB		
		00 - 7F	Plug-in Board Version Number		
	43	1	00 - 7F	reserved	
TOTAL SIZE = 68 44 (HEX)					

<Table 7>  
MIDI PARAMETER CHANGE TABLE  
(PERFORMANCE PART)

Address	Size	Data Range (HEX)	Parameter Name	Description	Notes
31 pp 00	1	00 - 7F	Bank Select MSB	0 - 127	
31 pp 01	1	00 - 7F	Bank Select LSB	0 - 127	
31 pp 02	1	00 - 7F	Program Number	1 - 128	
31 pp 03	1	00	reserved		
31 pp 04	1	00 - 01	Part Mode	mono, poly	
31 pp 05	1	01 - 7F	Velocity Limit Low	1 - 127	
31 pp 06	1	01 - 7F	Velocity Limit High	1 - 127	
31 pp 07	1	00 - 7F	Note Limit Low	C-2 - G8	
31 pp 08	1	00 - 7F	Note Limit High	C-2 - G8	
31 pp 09	1	10 - 58	Pitch Bend Range Upper	-48 - +24 (PB Part: -24 - +24)	
31 pp 0A	1	10 - 58	Pitch Bend Range Lower	-48 - +24	
31 pp 0B	1	00 - 7F	Velocity Sense Depth	0 - 127	
31 pp 0C	1	00 - 7F	Velocity Send Offset	0 - 127	
31 pp 0D	1	00 - 7F	Volume	0 - 127	
31 pp 0E	1	01 - 7F	Pan	L63 - C - R63	
31 pp 0F	1	40	reserved		
31 pp 10	2	00 - 0F	Detune MSB	-12.8 - +12.7[Hz]	
		00 - 0F	Detune LSB	1st bit 3-0 -> bit 7-4 2nd bit 3-0 -> bit 3-0	
31 pp 12	1	00 - 7F	Reverb Send	0 - 127	
31 pp 13	1	00 - 7F	Chorus Send	0 - 127	
31 pp 14	1	00 - 7F	Variation Send	0 - 127	
31 pp 15	1	00 - 7F	Dry Level	0 - 127	
31 pp 16	1	28 - 58	Note Shift	-24 - +24[semitones]	
31 pp 17	1	00 - 7F	Filter Cutoff Frequency	-64 - +63	
31 pp 18	1	00 - 7F	Filter Resonance/Width	-64 - +63	
31 pp 19	1	40	reserved		
31 pp 1A	1	00 - 01	Portamento Switch	off, on	
31 pp 1B	1	00 - 7F	Portamento Time	0 - 127	
31 pp 1C	1	00 - 01	Portamento Mode	fingered, fulltime	
31 pp 1D	1	00	reserved		
31 pp 1E	1	00 - 7F	Output Select	0: L&R 8: asnl&R, 10: asn1&2, 11 :asn3&4 64 - 65: asnL, asnR, 68 - 71 :asn1-4 127: drum (or L&R)	
31 pp 1F	1	00 - 7F	Layer Sw Arpeggio Sw Receive Control Change	bit0: Layer Sw off, on bit1: Arpeggio Sw off, on bit2: off, on Control Change bit3: reserved bit4: reserved bit5: off, on AT bit6: off, on PB	Part1:on, Other:off Part1:on, Other:off
31 pp 20	1	00 - 7F	Receive Expression	bit0: off, on Expression bit1: reserved bit2: reserved bit3: off, on Sustain/Sostenute bit4: reserved bit5: off, on MW bit6: reserved	
			Receive Sustain/Sostenute		
			Receive MW		

Address	Size	Data Range (HEX)	Parameter Name	Description	Notes
31 pp 21	1	00 - 7F	Receive FC2 Receive FS Receive FC1 Receive BC Receive AS1 Receive AS2	bit0: off, on FC2 bit1: off, on FS bit2: off, on FC1 bit3: off, on BC bit4: off, on AS1 bit5: off, on AS2 bit6: reserved	
31 pp 22	1	00 - 7F	AEG Decay2 Level (EG Sustain Level)	-64 - +63	
31 pp 23	1	00 - 7F	AEG Attack Time (EG Attack Time)	-64 - +63	
31 pp 24	1	00 - 01	Voice Pan on/off	off, on	
31 pp 25	1	00 - 7F	AEG Decay2 Time (EG Decay Time)	-64 - +63	
31 pp 26	1	00 - 7F	AEG Release Time (EG Release Time)	-64 - +63	
31 pp 27	1	00 - 7F	FEG Decay2 Level (EG Sustain Level)	-64 - +63	
31 pp 28	1	00 - 7F	FEG Attack Time (EG Attack Time)	-64 - +63	
31 pp 29	1	40	reserved		
31 pp 2A	1	00 - 7F	FEG Decay2 Time (EG Decay Time)	-64 - +63	
31 pp 2B	1	00 - 7F	FEG Release Time (EG Release Time)	-64 - +63	
31 pp 2C	1	00 - 7F	FEG DEPTH	-64 - +63	
TOTAL SIZE = 45 2D (HEX)					

pp = part number  
00 - OF Part 1 - 4 (Normal, Drum)  
60 Part Plug-in 1 (User, Preset, Direct)  
61 Part Plug-in 2 (User, Preset, Direct)  
62 Part Plug-in 3 (User, Preset, Direct)

<Table 8-1>  
MIDI PARAMETER CHANGE TABLE (NORMAL  
VOICE COMMON)

Address	Size	Data Range (HEX)	Parameter Name	Description	Notes
40 70 00	1	20 - 7E	Voice Name1	32..126(ASCII)	
40 70 01	1	20 - 7E	Voice Name2	32..126(ASCII)	
40 70 02	1	20 - 7E	Voice Name3	32..126(ASCII)	
40 70 03	1	20 - 7E	Voice Name4	32..126(ASCII)	
40 70 04	1	20 - 7E	Voice Name5	32..126(ASCII)	
40 70 05	1	20 - 7E	Voice Name6	32..126(ASCII)	
40 70 06	1	20 - 7E	Voice Name7	32..126(ASCII)	
40 70 07	1	20 - 7E	Voice Name8	32..126(ASCII)	
40 70 08	1	20 - 7E	Voice Name9	32..126(ASCII)	
40 70 09	1	20 - 7E	Voice Name10	32..126(ASCII)	
40 70 0A	1		reserved		
40 70 0B	1		reserved		
40 70 0C	1	00 - 10	Voice Category (Main)	0.16(--.Co)	Ap, Kb, Or, Gt, Ba, St, Br, Rp, Ld, Pd, Sc, Cp, Dr, Se, Me, Co
40 70 0D	1	00 - 03	Voice Category (Sub)	0.3(--.Sub1..Sub3)	
40 70 0E	1		reserved		
40 70 0F	1		reserved		
40 70 10	1		reserved		
40 70 11	1		reserved		
40 70 12	1		reserved		
40 70 13	1	00 - 02	QED ARP Type Bank	pre1, pre2, user	
40 70 14	1	00 - 7F	QED ARP Type	UpOct1 - GateCut3	
40 70 15	1	00 - 01	ARP Switch	off, on	
40 70 16	1	00 - 02	ARP Hold	sync-off, off, on	
40 70 17	1	00 - 06	ARP Unit Multiply	50%, 66%, 75%, 100%, 133%, 150%, 200%	
40 70 18	1	00 - 7F	ARP Note Limit Low	C-2..G8	
40 70 19	1	00 - 7F	ARP Note Limit High	C-2..G8	
40 70 1A	1	01 - 7F	ARP Velocity Limit Low	1 - 127	
40 70 1B	1	01 - 7F	ARP Velocity Limit High	1 - 127	
40 70 1C	1	00 - 02	ARP Key Mode	sort, thru, direct	
40 70 1D	1	00 - 01	ARP Vel Mode	original, thru	
40 70 1E	2	0000 - 00C8	ARP Velocity Rate MSB ARP Velocity Rate LSB	0...200%	
40 70 20	2	0000 - 00C8	ARP Gate Time Rate MSB ARP Gate Time Rate LSB	0...200%	
40 70 22	2	0001 - 012C	QED ARP Tempo MSB QED ARP Tempo LSB	1...300	
40 70 24	1	00 - 04	Function Select (CS Assign)	0=Pan&Send, 1= Tone, 2=Assign, 3=MeqOffset, 4=Volume	
40 70 25	1	01 - 7F	Pan	L63..C..R63	
40 70 26	1	00 - 7F	Chorus Control	-64..+63	
40 70 27	1	00 - 7F	QED Decay Time	-64..+63	
40 70 28	1	00 - 7F	QED Sustain Level	-64..+63	
40 70 29	1	00 - 7F	QED FEG Attack Time	-64..+63	
40 70 2A	1	00 - 7F	QED FEG Decay Time	-64..+63	
40 70 2B	1	00 - 7F	QED FEG Release Time	-64..+63	
40 70 2C	1	40	reserved		
40 70 2D	1	00 - 7F	QED FEG Depth	-64..+63	
40 70 2E	1	00 - 7F	ASA	-64..+63	
40 70 2F	1	00 - 7F	ASB	-64..+63	
40 70 30	1	40	reserved		
40 70 31	1	00 - 7F	EQ Low Gain	-64..+63	
40 70 32	1	00 - 7F	EQ Low Mid Gain	-64..+63	
40 70 33	1	00 - 7F	EQ High Mid Gain	-64..+63	
40 70 34	1	00 - 7F	EQ High Gain	-64..+63	
40 70 35	1	00 - 7F	Scene 1 Assign1	-64..+63	



Address	Size	Data Range (HEX)	Parameter Name	Description	Notes
40 70 36	1	00 - 7F	Scene 1 Assign2	-64..+63	
40 70 37	1	00 - 7F	Scene 1 Cutoff Frequency	-64..+63	
40 70 38	1	00 - 7F	Scene 1 Resonance	-64..+63	
40 70 39	1	00 - 7F	Scene 1 Attack Time	-64..+63	
40 70 3A	1	00 - 7F	Scene 1 Release Time	-64..+63	
40 70 3B	1	40	reserved		
40 70 3C	1	40	reserved		
40 70 3D	1	40	reserved		
40 70 3E	1	40	reserved		
40 70 3F	1	40	reserved		
40 70 40	1	40	reserved		
40 70 41	1	00	reserved		

TOTAL SIZE = 66 42 (HEX)

40 00 00	1	03	reserved		
40 00 01	1	00 - 7F	Volume	0 - 127	
40 00 02	1	00 - 01	Same Note Number Key On Assign	single, multi	
40 00 03	1	00 - 01	QED Mono/Poly Mode	mono, poly	
40 00 04	1	00 - 1F	Micro Tuning	Equal - Indian	
40 00 05	1	10 - 58	QED Pitch Bend Range Upper	-48 - +24[semitones]	
40 00 06	1	10 - 58	QED Pitch Bend Range Lower	-48 - +24[semitones]	
40 00 07	1	00 - 01	QED Portamento Mode	fingered, fulltime	
40 00 08	1	00 - 01	QED Portamento Switch	off, on	
40 00 09	1	00 - 7F	QED Portamento Time	0 - 127	
40 00 0A	1	00 - 01	Portamento Time Mode	rate, time	
40 00 0B	1	00 - 7F	Reverb Send	~<dB...0dB	
40 00 0C	1	00 - 7F	Chorus Send	~<dB...0dB	
40 00 0D	1	00	reserved		
40 00 0E	1	7F	reserved		

TOTAL SIZE = 15 0F (HEX)

40 00 40	1	00 - 02	Insertion Connect Type	Para, S -L, L -S	
40 00 41	1	7F	reserved		
40 00 42	1	7F	reserved		
40 00 43	1	00	reserved		

TOTAL SIZE = 4 04 (HEX)

40 01 00	2	00 - 7F	Reverb Type MSB	Refer to Effect Parameter List	
		00 - 7F	Reverb Type LSB		
40 01 02	2	00 - 7F	Reverb Parameter 1 MSB	-	
		00 - 7F	Reverb Parameter 1 LSB		
40 01 04	2	00 - 7F	Reverb Parameter 2 MSB	-	
		00 - 7F	Reverb Parameter 2 LSB		
40 01 06	2	00 - 7F	Reverb Parameter 3 MSB	-	
		00 - 7F	Reverb Parameter 3 LSB		
40 01 08	2	00 - 7F	Reverb Parameter 4 MSB	-	
		00 - 7F	Reverb Parameter 4 LSB		
40 01 0A	2	00 - 7F	Reverb Parameter 5 MSB	-	
		00 - 7F	Reverb Parameter 5 LSB		
40 01 0C	2	00 - 7F	Reverb Parameter 6 MSB	-	
		00 - 7F	Reverb Parameter 6 LSB		
40 01 0E	2	00 - 7F	Reverb Parameter 7 MSB	-	
		00 - 7F	Reverb Parameter 7 LSB		
40 01 10	2	00 - 7F	Reverb Parameter 8 MSB	-	
		00 - 7F	Reverb Parameter 8 LSB		
40 01 12	2	00 - 7F	Reverb Parameter 9 MSB	-	
		00 - 7F	Reverb Parameter 9 LSB		
40 01 14	2	00 - 7F	Reverb Parameter 10 MSB	-	
		00 - 7F	Reverb Parameter 10 LSB		
40 01 16	1	00 - 7F	Reverb Return	~<dB...0dB...+6dB(0...96...127)	
40 01 17	1	01 - 7F	Reverb Pan	L63...C...R63	

TOTAL SIZE = 24 18 (HEX)

40 02 00	2	00 - 7F	Chorus Type MSB	Refer to Effect Parameter List	
		00 - 7F	Chorus Type LSB		
40 02 02	2	00 - 7F	Chorus Parameter 1 MSB	-	
		00 - 7F	Chorus Parameter 1 LSB		
40 02 04	2	00 - 7F	Chorus Parameter 2 MSB	-	
		00 - 7F	Chorus Parameter 2 LSB		
40 02 06	2	00 - 7F	Chorus Parameter 3 MSB	-	
		00 - 7F	Chorus Parameter 3 LSB		
40 02 08	2	00 - 7F	Chorus Parameter 4 MSB	-	
		00 - 7F	Chorus Parameter 4 LSB		
40 02 0A	2	00 - 7F	Chorus Parameter 5 MSB	-	
		00 - 7F	Chorus Parameter 5 LSB		
40 02 0C	2	00 - 7F	Chorus Parameter 6 MSB	-	
		00 - 7F	Chorus Parameter 6 LSB		
40 02 0E	2	00 - 7F	Chorus Parameter 7 MSB	-	
		00 - 7F	Chorus Parameter 7 LSB		
40 02 10	2	00 - 7F	Chorus Parameter 8 MSB	-	
		00 - 7F	Chorus Parameter 8 LSB		
40 02 12	2	00 - 7F	Chorus Parameter 9 MSB	-	
		00 - 7F	Chorus Parameter 9 LSB		
40 02 14	2	00 - 7F	Chorus Parameter 10 MSB	-	
		00 - 7F	Chorus Parameter 10 LSB		
40 02 16	1	00 - 7F	Chorus Return	~<dB...0dB...+6dB(0...96...127)	
40 02 17	1	01 - 7F	Chorus Pan	L63...C...R63	
40 02 18	1	00 - 7F	Send Chorus To Reverb	~<dB...0dB(0...127)	

TOTAL SIZE = 25 19 (HEX)

Address	Size	Data Range (HEX)	Parameter Name	Description	Notes
40 03 00	2	00 - 7F	Insertion-1 Type MSB	Refer to Effect Parameter List	
		00 - 7F	Insertion-1 Type LSB		
40 03 02	2	00 - 7F	Insertion-1 Parameter1 MSB	-	
		00 - 7F	Insertion-1 Parameter1 LSB		
40 03 04	2	00 - 7F	Insertion-1 Parameter2 MSB	-	
		00 - 7F	Insertion-1 Parameter2 LSB		
40 03 06	2	00 - 7F	Insertion-1 Parameter3 MSB	-	
		00 - 7F	Insertion-1 Parameter3 LSB		
40 03 08	2	00 - 7F	Insertion-1 Parameter4 MSB	-	
		00 - 7F	Insertion-1 Parameter4 LSB		
40 03 0A	2	00 - 7F	Insertion-1 Parameter5 MSB	-	
		00 - 7F	Insertion-1 Parameter5 LSB		
40 03 0C	2	00 - 7F	Insertion-1 Parameter6 MSB	-	
		00 - 7F	Insertion-1 Parameter6 LSB		
40 03 0E	2	00 - 7F	Insertion-1 Parameter7 MSB	-	
		00 - 7F	Insertion-1 Parameter7 LSB		
40 03 10	2	00 - 7F	Insertion-1 Parameter8 MSB	-	
		00 - 7F	Insertion-1 Parameter8 LSB		
40 03 12	2	00 - 7F	Insertion-1 Parameter9 MSB	-	
		00 - 7F	Insertion-1 Parameter9 LSB		
40 03 14	2	00 - 7F	Insertion-1 Parameter10 MSB	-	
		00 - 7F	Insertion-1 Parameter10 LSB		

TOTAL SIZE = 22 16 (HEX)

40 04 00	2	00 - 7F	Insertion-2 Type MSB	Refer to Effect Parameter List	
		00 - 7F	Insertion-2 Type LSB		
40 04 02	2	00 - 7F	Insertion-2 Parameter 1 MSB	-	
		00 - 7F	Insertion-2 Parameter 1 LSB		
40 04 04	2	00 - 7F	Insertion-2 Parameter 2 MSB	-	
		00 - 7F	Insertion-2 Parameter 2 LSB		
40 04 06	2	00 - 7F	Insertion-2 Parameter 3 MSB	-	
		00 - 7F	Insertion-2 Parameter 3 LSB		
40 04 08	2	00 - 7F	Insertion-2 Parameter 4 MSB	-	
		00 - 7F	Insertion-2 Parameter 4 LSB		
40 04 0A	2	00 - 7F	Insertion-2 Parameter 5 MSB	-	
		00 - 7F	Insertion-2 Parameter 5 LSB		
40 04 0C	2	00 - 7F	Insertion-2 Parameter 6 MSB	-	
		00 - 7F	Insertion-2 Parameter 6 LSB		
40 04 0E	2	00 - 7F	Insertion-2 Parameter 7 MSB	-	
		00 - 7F	Insertion-2 Parameter 7 LSB		
40 04 10	2	00 - 7F	Insertion-2 Parameter 8 MSB	-	
		00 - 7F	Insertion-2 Parameter 8 LSB		
40 04 12	2	00 - 7F	Insertion-2 Parameter 9 MSB	-	
		00 - 7F	Insertion-2 Parameter 9 LSB		
40 04 14	2	00 - 7F	Insertion-2 Parameter 10 MSB	-	
		00 - 7F	Insertion-2 Parameter 10 LSB		
40 04 16	2	00 - 7F	Insertion-2 Parameter 11 MSB	-	
		00 - 7F	Insertion-2 Parameter 11 LSB		
40 04 18	2	00 - 7F	Insertion-2 Parameter 12 MSB	-	
		00 - 7F	Insertion-2 Parameter 12 LSB		
40 04 1A	2	00 - 7F	Insertion-2 Parameter 13 MSB	-	
		00 - 7F	Insertion-2 Parameter 13 LSB		
40 04 1C	2	00 - 7F	Insertion-2 Parameter 14 MSB	-	
		00 - 7F	Insertion-2 Parameter 14 LSB		
40 04 1E	2	00 - 7F	Insertion-2 Parameter 15 MSB	-	
		00 - 7F	Insertion-2 Parameter 15 LSB		
40 04 20	2	00 - 7F	Insertion-2 Parameter 16 MSB	-	
		00 - 7F	Insertion-2 Parameter 16 LSB		

TOTAL SIZE = 34 22 (HEX)

40 05 00	1	00 - 09	Controller Set1 Source	PB, MW, ..., AT, FC2, FS, FC1, BC, AS1, AS2	
40 05 01	2	00	Controller Set1 Destination MSB	0 - 62	
		00 - 3E	Controller Set1 Destination LSB		
40 05 03	1	00 - 7F	Controller Set1 Depth	-64 - +63	
40 05 04	1		reserved		
40 05 05	1	00 - 09	Controller Set2 Source	PB, MW, ..., AT, FC2, FS, FC1, BC, AS1, AS2	
40 05 06	2	00	Controller Set2 Destination MSB	0 - 62	
		00 - 3E	Controller Set2 Destination LSB		
40 05 08	1	00 - 7F	Controller Set2 Depth	-64 - +63	
40 05 09	1		reserved		
40 05 0A	1	00 - 09	Controller Set3 Source	PB, MW, ..., AT, FC2, FS, FC1, BC, AS1, AS2	
40 05 0B	2	00	Controller Set3 Destination MSB	0 - 62	
		00 - 3E	Controller Set3 Destination LSB		
40 05 0D	1	00 - 7F	Controller Set3 Depth	-64 - +63	
40 05 0E	1		reserved		
40 05 0F	1	00 - 09	Controller Set4 Source	PB, MW, ..., AT, FC2, FS, FC1, BC, AS1, AS2	
40 05 10	2	00	Controller Set4 Destination MSB	0 - 62	
		00 - 3E	Controller Set4 Destination LSB		
40 05 12	1	00 - 7F	Controller Set4 Depth	-64 - +63	
40 05 13	1		reserved		
40 05 14	1	00 - 09	Controller Set5 Source	PB, MW, ..., AT, FC2, FS, FC1, BC, AS1, AS2	
40 05 15	2	00	Controller Set5 Destination MSB	0 - 62	
		00 - 3E	Controller Set5 Destination LSB		
40 05 17	1	00 - 7F	Controller Set5 Depth	-64 - +63	
40 05 18	1		reserved		
40 05 19	1	00 - 09	Controller Set6 Source	PB, MW, ..., AT, FC2, FS, FC1, BC, AS1, AS2	

Address	Size	Data Range (HEX)	Parameter Name	Description	Notes
40 05 1A	2	00 00-3E	Controller Set6 Destination MSB Controller Set6 Destination LSB	0 - 62	
40 05 1C	1	00 - 7F	Controller Set6 Depth	-64 - +63	
40 05 1D	1	00 - 0F	reserved		

TOTAL SIZE = 30 1E (HEX)

40 06 00	1	00 - 05	LFO Phase	0, 90, 120, 180, 240, 270	
40 06 01	1	00 - 0C	LFO Wave	tri, tri-, sawup, sawdwn, squ1/4, squ1/3, squ, squ2/3, squ3/4, trpz, S/H1, S/H2, user	
40 06 02	1	00 - 3F	LFO Speed	0 - 63 (available only when the Tempo Sync is set to off)	
40 06 03	1	05 - 15	LFO TEMPO SPEED	5 - 21 (available only when the Tempo Sync is set to off)	16th, 8th/3, 16th, 8th, 4th/3, 8th, 4th, 2th/3, 4th, 2nd, Whole/3, 2nd, 4thX4, 4thX6, 4thX6, 4thX7, 4thX8
40 06 04	1	00 - 01	LFO TEMPO SYNC	OFF, ON	
40 06 05	1	00 - 7F	LFO Delay Time	0 - 127	
40 06 06	1	00 - 7F	LFO Fade In Time	0 - 127	
40 06 07	1	00 - 7F	LFO Hold Time	0 - 127	
40 06 08	1	00 - 7F	LFO Fade Out Time	0 - 127	
40 06 09	1	00 - 02	LFO Key On Reset	off, each-on, 1st-on	
40 06 0A	1	00 - 05	LFO Box1 Destination (DEST1)	AMD, PMD, FMD, RESO, PAN, ELEMENT LFO SPEED	
40 06 0B	1	00 - 7F	LFO Box1 Depth	0 - 127	
40 06 0C	1		reserved		
40 06 0D	1	00 - 05	LFO Box2 Destination (DEST2)	AMD, PMD, FMD, RESO, PAN, ELEMENT LFO SPEED	
40 06 0E	1	00 - 7F	LFO Box2 Depth	0 - 127	
40 06 0F	1		reserved		
40 06 10	1	00 - 05	LFO Box3 Destination (DEST3)	AMD, PMD, FMD, RESO, PAN, ELEMENT LFO SPEED	
40 06 11	1	00 - 7F	LFO Box3 Depth	0 - 127	
40 06 12	1		reserved		
40 06 13	1	00 - 06	USER WAVE TOTAL STEP	2, 3, 4, 6, 8, 12, 16	
40 06 14	1	00 - 03	USER WAVE SLOPE	OFF, UP, DOWN, UP&DOWN	
40 06 15	1	00 - 7F	USER WAVE STEP VALUE1	0 - 127	
40 06 16	1	00 - 7F	USER WAVE STEP VALUE2	0 - 127	
40 06 17	1	00 - 7F	USER WAVE STEP VALUE3	0 - 127	
40 06 18	1	00 - 7F	USER WAVE STEP VALUE4	0 - 127	
40 06 19	1	00 - 7F	USER WAVE STEP VALUE5	0 - 127	
40 06 1A	1	00 - 7F	USER WAVE STEP VALUE6	0 - 127	
40 06 1B	1	00 - 7F	USER WAVE STEP VALUE7	0 - 127	
40 06 1C	1	00 - 7F	USER WAVE STEP VALUE8	0 - 127	
40 06 1D	1	00 - 7F	USER WAVE STEP VALUE9	0 - 127	
40 06 1E	1	00 - 7F	USER WAVE STEP VALUE10	0 - 127	
40 06 1F	1	00 - 7F	USER WAVE STEP VALUE11	0 - 127	
40 06 20	1	00 - 7F	USER WAVE STEP VALUE12	0 - 127	
40 06 21	1	00 - 7F	USER WAVE STEP VALUE13	0 - 127	
40 06 22	1	00 - 7F	USER WAVE STEP VALUE14	0 - 127	
40 06 23	1	00 - 7F	USER WAVE STEP VALUE15	0 - 127	
40 06 24	1	00 - 7F	USER WAVE STEP VALUE16	0 - 127	

TOTAL SIZE = 37 25 (HEX)

<Table 8-2>  
MIDI PARAMETER CHANGE TABLE (NORMAL VOICE ELEMENT)

Address	Size	Data Range (HEX)	Parameter Name	Description	Notes
41 ee 00	1	00 - 01	ELEMENT ASSIGN	0:OFF, 1:ON	
41 ee 01	1	00	WAVE SELECT	0:PRESET	
41 ee 02	1	00	reserved		
41 ee 03	2	00 - 7F	Wave Number MSB	0 - 16383 (User: 0-256)	
			Wave Number LSB	1st bit 6-0 → bit 13-7	
41 ee 05	1	01	reserved		
41 ee 06	1	01	reserved		
41 ee 07	1	00	reserved		
41 ee 08	1	01 - 7F	Pan	L63 - C - R63	
41 ee 09	1	00 - 7F	Random Pan Depth	0 - 127	
41 ee 0A	1	00 - 7F	Alternate Pan Depth	L64 - 0 - R63	
41 ee 0B	1	00 - 7F	Scaling Pan Depth	-64 - +63	
41 ee 0C	1	00 - 7F	Note Limit Low	0 - 127	
41 ee 0D	1	00 - 7F	Note Limit High	0 - 127	
41 ee 0E	1	01 - 7F	Velocity Limit Low	1 - 127	
41 ee 0F	1	01 - 7F	Velocity Limit High	1 - 127	
41 ee 10	1	00 - 7F	VELOCITY CROSS FADE	0 - 127	
41 ee 11	1	00 - 7F	Key On Delay	0 - 127	
41 ee 12	1	00	reserved		
41 ee 13	1	7F	reserved		
41 ee 14	1	7F	reserved		
41 ee 15	1	00	RESERVE	RESERVE for ELEMENT VAR SEND	
41 ee 16	1	00 - 02	Insertion Effect Switch	thru, ins1, ins2	
41 ee 17	1	00	reserved		
41 ee 18	2	00 - 00	CONTROL BOX SW	BIT0-6:RESERVE	
				BIT0-5:BOX1-BOX6, BIT6:RESERVE	
41 ee 1A	2	00 - 00	LFO BOX SW	BIT0-6:RESERVE	
				BIT0-2:BOX1-BOX3, BIT3-6:RESERVE	

TOTAL SIZE = 28 1C (HEX)

Address	Size	Data Range (HEX)	Parameter Name	Description	Notes
41 ee 20	1	00 - 7F	Element Level	0 - 127	
41 ee 21	1	00 - 7F	Level Velocity Sensitivity	-64 - +63	
41 ee 22	1	00 - 04	LEVEL SENS VELOCITY CURVE	00 - 04	
41 ee 23	1	00	reserved		
41 ee 24	1	00 - 7F	AEG Attack Time	0 - 127	
41 ee 25	1	00 - 7F	AEG Decay1 Time	0 - 127	
41 ee 26	1	00 - 7F	AEG Decay2 Time	0 - 127	
41 ee 27	1	00 - 7F	AEG Release Time	0 - 127	
41 ee 28	1	00 - 7F	AEG Init Level	0 - 127	
41 ee 29	1	00	reserved		
41 ee 2A	1	00 - 7F	AEG Decay1 Level	0 - 127	
41 ee 2B	1	00 - 7F	AEG Sustain Level	0 - 127	
41 ee 2C	1	00	reserved		
41 ee 2D	1	00 - 04	AEG Time Velocity Segment	ATK, ATK+DCY, DCY, ATK+RLS, ALL	
41 ee 2E	1	00 - 7F	AEG Time Velocity Sensitivity	-64 - +63	
41 ee 2F	1	00 - 7F	Level Key Follow Sensitivity	-200% - +200%	
41 ee 30	1	00 - 7F	Level Scaling Break Point 1	C -2 - E8	BP1<BP2<BP3<BP4
41 ee 31	1	01 - 7D	Level Scaling Break Point 2	C#-2 - F8	BP1<BP2<BP3<BP4
41 ee 32	1	02 - 7E	Level Scaling Break Point 3	D -2 - F#8	BP1<BP2<BP3<BP4
41 ee 33	1	03 - 7F	Level Scaling Break Point 4	D#-2 - G8	BP1<BP2<BP3<BP4
41 ee 34	2	00 - 01	Level Scaling Offset 1	-128 - +127	
			00 - 7F		
41 ee 36	2	00 - 01	Level Scaling Offset 2	-128 - +127	
			00 - 7F		
41 ee 38	2	00 - 01	Level Scaling Offset 3	-128 - +127	
			00 - 7F		
41 ee 3A	2	00 - 01	Level Scaling Offset 4	-128 - +127	
			00 - 7F		
41 ee 3C	1	00 - 7F	AEG Time Key Follow Sensitivity	-64 - +63	
41 ee 3D	1	00 - 7F	AEG Time Key Follow Center Key	C-2 - G8	

TOTAL SIZE = 30 1E (HEX)

42 ee 00	1	10 - 70	Coarse Tune	-48 - +48	
42 ee 01	1	00 - 7F	Fine Tune	-64 - +63	
42 ee 02	1	00 - 7F	VELOCITY →PITCH SENSITIVITY	-64 - +63	
42 ee 03	1	00	reserved		
42 ee 04	1	00 - 7F	Random Pitch Depth	0 - 127	
42 ee 05	1	00 - 7F	PEG Hold Time	0 - 127	
42 ee 06	1	00 - 7F	PEG Attack Time	0 - 127	
42 ee 07	1	00 - 7F	PEG Decay1 Time	0 - 127	
42 ee 08	1	00 - 7F	PEG Decay2 Time	0 - 127	
42 ee 09	1	00 - 7F	PEG Release Time	0 - 127	
42 ee 0A	2	00 - 01	PEG Hold Level	-128 - +127 (-4800 - +4800[cent])	
			00 - 7F		
42 ee 0C	2	00 - 01	PEG Attack Level	-128 - +127 (-4800 - +4800[cent])	
			00 - 7F		
42 ee 0E	2	00 - 01	PEG Decay1 Level	-128 - +127 (-4800 - +4800[cent])	
			00 - 7F		
42 ee 10	2	00 - 01	PEG Sustain Level	-128 - +127 (-4800 - +4800[cent])	
			00 - 7F		
42 ee 12	2	00 - 01	PEG Release Level	-128 - +127 (-4800 - +4800[cent])	
			00 - 7F		
42 ee 14	1	00 - 7F	PEG Depth	-64 - +63	
42 ee 15	1	00 - 04	PEG Time Velocity Segment	ATK, ATK+DCY, DCY, ATK+RLS, ALL	
42 ee 16	1	00 - 7F	PEG Time Velocity Sensitivity	-64 - +63	
42 ee 17	1	00 - 7F	PEG Level Velocity Sensitivity	-64 - +63	
42 ee 18	1	00 - 04	PEG LEVEL SENS VELOCITY CURVE	00 - 04	
42 ee 19	1	00 - 7F	Pitch Key Follow Sensitivity	-200% - +200%	
42 ee 1A	1	00 - 7F	Pitch Key Follow Center Key	C-2 - G8	
42 ee 1B	1	00 - 7F	PEG Time Key Follow Sensitivity	-64 - +63	
42 ee 1C	1	00 - 7F	PEG Time Key Follow Center Key	C-2 - G8	

TOTAL SIZE = 29 1D (HEX)



Address	Size	Data Range (HEX)	Parameter Name	Description	Notes
43 ee 00	1	00 - 15	Filter Type	LPF24D, LPF24A, LPF18, LPF18s, LPF12, LPF6, HPF24D, HPF12, BPF12D, BPF12s, BPF6, BPFw, BEF12, BEF6, DualLPF, DualHPF, DualBPF, DualBEF, LPF12+HPF12, LPF12+BPF6, HPF12+BPF6, THRU	
43 ee 01	2	00 - 01 00 - 7F	Filter Cutoff Frequency	0 - 255	
43 ee 03	1	00 - 7F	Filter Cutoff Velocity Sensitivity	-64 - +63	
43 ee 04	1	02	reserved		
43 ee 05	1	00 - 1F	Filter Resonance/Width/Band	0 - 31	
43 ee 06	1	00 - 7F	Filter Resonance Velocity Sensitivity	-64 - +63	
43 ee 07	2	00 - 01 00 - 7F	HPF Cutoff Frequency	0 - 255	
43 ee 09	1	40	reserved		
43 ee 0A	2	00 - 01 00 - 7F	Distance	0 - 255	
43 ee 0C	2	00 - 01 00 - 7F	Filter Gain	0 - 255	
43 ee 0E	1	00 - 7F	FEG Hold Time	0 - 127	
43 ee 0F	1	00 - 7F	FEG Attack Time	0 - 127	
43 ee 10	1	00 - 7F	FEG Decay1 Time	0 - 127	
43 ee 11	1	00 - 7F	FEG Decay2 Time	0 - 127	
43 ee 12	1	00 - 7F	FEG Release Time	0 - 127	
43 ee 13	2	00 - 01 00 - 7F	FEG Hold Level	-128 - +127 (-9600 - +9600[cent])	
43 ee 15	2	00 - 01 00 - 7F	FEG Attack Level	-128 - +127 (-9600 - +9600[cent])	
43 ee 17	2	00 - 01 00 - 7F	FEG Decay1 Level	-128 - +127 (-9600 - +9600[cent])	
43 ee 19	2	00 - 01 00 - 7F	FEG Sustain Level	-128 - +127 (-9600 - +9600[cent])	
43 ee 1B	2	00 - 01 00 - 7F	FEG Release Level	-128 - +127 (-9600 - +9600[cent])	
43 ee 1D	1	00 - 7F	FEG Depth	-64 - +63	
43 ee 1E	1	00 - 04	FEG Time Velocity Segment	ATK, ATK+DCY, DCY, ATK+RLS, ALL	
43 ee 1F	1	00 - 7F	FEG Time Velocity Sensitivity	-64 - +63	
43 ee 20	1	00 - 7F	FEG Level Velocity Sensitivity	-64 - +63	
43 ee 21	1	00 - 04	FEG LEVEL VELOCITY CURVE	00 - 04	
43 ee 22	1	00 - 7F	Filter Cutoff Key Follow Sensitivity	-200% - +200%	
43 ee 23	1	00 - 7C	Filter Cutoff Scaling Break Point 1	C -2 - E8	BP1-BP2<BP3<BP4
43 ee 24	1	01 - 7D	Filter Cutoff Scaling Break Point 2	C#-2 - F8	BP1<BP2<BP3<BP4
43 ee 25	1	02 - 7E	Filter Cutoff Scaling Break Point 3	D -2 - F#8	BP1<BP2<BP3<BP4
43 ee 26	1	03 - 7F	Filter Cutoff Scaling Break Point 4	D#-2 - G8	BP1<BP2<BP3<BP4
43 ee 27	2	00 - 01 00 - 7F	Filter Cutoff Scaling Offset 1	-128 - +127	
43 ee 29	2	00 - 01 00 - 7F	Filter Cutoff Scaling Offset 2	-128 - +127	
43 ee 2B	2	00 - 01 00 - 7F	Filter Cutoff Scaling Offset 3	-128 - +127	
43 ee 2D	2	00 - 01 00 - 7F	Filter Cutoff Scaling Offset 4	-128 - +127	
43 ee 2F	1	00 - 7F	HPF Cutoff Key Follow Sensitivity	-200% - +200%	
43 ee 30	1	00 - 7F	FEG Time Key Follow Sensitivity	-64 - +63	
43 ee 31	1	00 - 7F	FEG Time Key Follow Center Key	C-2 - G8	

TOTAL SIZE = 50 32 (HEX)

44 ee 00	1	00 - 05	EQ Type	EQ L/H, PEQ, Boost6, Boost12, Boost18, thru	
44 ee 01	1	00 - 1F	EQ Resonance	0 - 31	
44 ee 02	2	00 - 01 00 - 7F	EQ 1 Frequency	EQ L/H: 46-182, PEQ: 83-251	
44 ee 04	1	20 - 60	EQ 1 Gain	-32 - +32	
44 ee 05	2	00 - 01 00 - 7F	EQ 2 Frequency	EQ L/H:131-241	
44 ee 07	1	20 - 60	EQ 2 Gain	-32 - +32	

TOTAL SIZE = 8 08 (HEX)

44 ee 40	1	00 - 02	LFO Wave	saw,tri,squ	
44 ee 41	1	00 - 01	LFO Key On Sync	off,on	
44 ee 42	1	00 - 7F	LFO KEY ON DELAY TIME	0 - 127	
44 ee 43	1	00 - 3F	LFO Speed	0 - 63	
44 ee 44	1	00 - 7F	LFO AMod Depth	0 - 127	
44 ee 45	1	00 - 7F	LFO PMod Depth	0 - 127	
44 ee 46	1	00 - 7F	LFO FMod Depth	0 - 127	

TOTAL SIZE = 7 07 (HEX)

ee = Element Number (00..03: Element1..4)

<Table 9-1>  
MIDI PARAMETER CHANGE TABLE (DRUM VOICE COMMON)

Address	Size	Data Range (HEX)	Parameter Name	Description	Notes
46 70 00	1	20 - 7E	Voice Name1	32..126(ASCII)	
46 70 01	1	20 - 7E	Voice Name2	32..126(ASCII)	
46 70 02	1	20 - 7E	Voice Name3	32..126(ASCII)	
46 70 03	1	20 - 7E	Voice Name4	32..126(ASCII)	
46 70 04	1	20 - 7E	Voice Name5	32..126(ASCII)	
46 70 05	1	20 - 7E	Voice Name6	32..126(ASCII)	
46 70 06	1	20 - 7E	Voice Name7	32..126(ASCII)	
46 70 07	1	20 - 7E	Voice Name8	32..126(ASCII)	
46 70 08	1	20 - 7E	Voice Name9	32..126(ASCII)	
46 70 09	1	20 - 7E	Voice Name10	32..126(ASCII)	
46 70 0A	1		reserved		
46 70 0B	1		reserved		
46 70 0C	1	00 - 10	Voice Category(Main)	0..16(--..Co)	Ap, Kb, Or, Gt, Ba,St, Br, Rp, Ld, Pd, Sc, Cp, Dr, Se, Me, Co
46 70 0D	1	00 - 03	Voice Category(Sub)	0..3(--.Sub1..Sub3)	depends on Main Category
46 70 0E	1		reserved		
46 70 0F	1		reserved		
46 70 10	1		reserved		
46 70 11	1		reserved		
46 70 12	1		reserved		
46 70 13	1	00 - 02	QED ARP Type Bank	pre1, pre2, user	
46 70 14	1	00 - 7F	QED ARP Type	BigBeat1 - Drm&Bs2 + α	
46 70 15	1	00 - 01	ARP Switch	off, on	
46 70 16	1	00 - 02	ARP Hold	sync-off, off, on	
46 70 17	1	00 - 06	ARP Unit Multiply	50%, 66%, 75%, 100%, 133%, 150%, 200%	
46 70 18	1	00 - 7F	ARP Note Limit Low	C-2..G8	
46 70 19	1	00 - 7F	ARP Note Limit High	C-2..G8	
46 70 1A	1	01 - 7F	ARP Velocity Limit Low	1 - 127	
46 70 1B	1	01 - 7F	ARP Velocity Limit High	1 - 127	
46 70 1C	1	00 - 02	ARP Key Mode	sort, thru, direct	
46 70 1D	1	00 - 01	ARP Vel Mode	original, thru	
46 70 1E	2	0000 - 00C8	ARP Velocity Rate MSB	0..200%	
46 70 20	2	0000 - 00C8	ARP Velocity Rate LSB		
46 70 22	2	0001 - 012C	ARP Gate Time Rate MSB	0..200%	
46 70 22	2	0001 - 012C	ARP Gate Time Rate LSB		
46 70 22	2	0001 - 012C	QED ARP Tempo MSB	1..300	
46 70 22	2	0001 - 012C	QED ARP Tempo LSB		
46 70 24	1	00 - 04	CS Function Select (CONTROL FUNCTION)	0=Pan&Send, 1= Tone, 2=Assign, 3=MeqOffset, 4=Volume	
46 70 25	1	01 - 7F	Pan	L63..C..R63	
46 70 26	1	00 - 7F	Chorus Control	-64..+63	
46 70 27	1	00 - 7F	QED Decay Time	-64..+63	
46 70 28	1	40	reserved		
46 70 29	1	40	reserved		
46 70 2A	1	40	reserved		
46 70 2B	1	40	reserved		
46 70 2C	1	40	reserved		
46 70 2D	1	40	reserved		
46 70 2E	1	00 - 7F	ASA	-64..+63	
46 70 2F	1	00 - 7F	ASB	-64..+63	
46 70 30	1	40	reserved		
46 70 31	1	00 - 7F	EQ Low Gain	-64..+63	
46 70 32	1	00 - 7F	EQ Low Mid Gain	-64..+63	
46 70 33	1	00 - 7F	EQ High Mid Gain	-64..+63	
46 70 34	1	00 - 7F	EQ High Gain	-64..+63	
46 70 35	1	00 - 7F	Scene 1 Assign1	-64..+63	
46 70 36	1	00 - 7F	Scene 1 Assign2	-64..+63	
46 70 37	1	00 - 7F	Scene 1 Cutoff Frequency	-64..+63	
46 70 38	1	00 - 7F	Scene 1 Resonance	-64..+63	
46 70 39	1	00 - 7F	Scene 1 Attack Time	-64..+63	
46 70 3A	1	40	reserved		
46 70 3B	1	40	reserved		
46 70 3C	1	40	reserved		
46 70 3D	1	40	reserved		
46 70 3E	1	40	reserved		
46 70 3F	1	40	reserved		
46 70 40	1	40	reserved		
46 70 41	1	00	reserved		

TOTAL SIZE = 66 42 (HEX)

46 00 00	1	00 - 7F	Volume	0 - 127	
46 00 01	1	00	reserved		
46 00 02	1	10 - 58	QED Pitch Bend Range Upper	-48 - +24[semitones]	
46 00 03	1	10 - 58	QED Pitch Bend Range Lower	-48 - +24[semitones]	
46 00 04	1	00 - 7F	Reverb Send	--dB...0dB	
46 00 05	1	00 - 7F	Chorus Send	--dB...0dB	
46 00 06	1	00	reserved		
46 00 07	1	7F	reserved		

TOTAL SIZE = 8 08 (HEX)

Address	Size	Data Range (HEX)	Parameter Name	Description	Notes
46 00 40	1	00 - 02	Insertion Connect Type	Para, S->L, L->S	
46 00 41	1	00 - 7F	Ins-EF Reverb Send Level	0 - 127	
46 00 42	1	00 - 7F	Ins-EF Chorus Send Level	0 - 127	
46 00 43	1	00	reserved		

TOTAL SIZE = 4 04 (HEX)

46 01 00	2	00 - 7F	Reverb Type MSB	Refer to Effect Parameter List	
		00 - 7F	Reverb Type LSB		
46 01 02	2	00 - 7F	Reverb Parameter 1 MSB	-	
		00 - 7F	Reverb Parameter 1 LSB		
46 01 04	2	00 - 7F	Reverb Parameter 2 MSB	-	
		00 - 7F	Reverb Parameter 2 LSB		
46 01 06	2	00 - 7F	Reverb Parameter 3 MSB	-	
		00 - 7F	Reverb Parameter 3 LSB		
46 01 08	2	00 - 7F	Reverb Parameter 4 MSB	-	
		00 - 7F	Reverb Parameter 4 LSB		
46 01 0A	2	00 - 7F	Reverb Parameter 5 MSB	-	
		00 - 7F	Reverb Parameter 5 LSB		
46 01 0C	2	00 - 7F	Reverb Parameter 6 MSB	-	
		00 - 7F	Reverb Parameter 6 LSB		
46 01 0E	2	00 - 7F	Reverb Parameter 7 MSB	-	
		00 - 7F	Reverb Parameter 7 LSB		
46 01 10	2	00 - 7F	Reverb Parameter 8 MSB	-	
		00 - 7F	Reverb Parameter 8 LSB		
46 01 12	2	00 - 7F	Reverb Parameter 9 MSB	-	
		00 - 7F	Reverb Parameter 9 LSB		
46 01 14	2	00 - 7F	Reverb Parameter 10 MSB	-	
		00 - 7F	Reverb Parameter 10 LSB		
46 01 16	1	00 - 7F	Reverb Return	<-dB...0dB...+6dB(0...96...127)	
46 01 17	1	01 - 7F	Reverb Pan	L63...C...R63	

TOTAL SIZE = 24 18 (HEX)

46 02 00	2	00 - 7F	Chorus Type MSB	Refer to Effect Parameter List	
		00 - 7F	Chorus Type LSB		
46 02 02	2	00 - 7F	Chorus Parameter 1 MSB	-	
		00 - 7F	Chorus Parameter 1 LSB		
46 02 04	2	00 - 7F	Chorus Parameter 2 MSB	-	
		00 - 7F	Chorus Parameter 2 LSB		
46 02 06	2	00 - 7F	Chorus Parameter 3 MSB	-	
		00 - 7F	Chorus Parameter 3 LSB		
46 02 08	2	00 - 7F	Chorus Parameter 4 MSB	-	
		00 - 7F	Chorus Parameter 4 LSB		
46 02 0A	2	00 - 7F	Chorus Parameter 5 MSB	-	
		00 - 7F	Chorus Parameter 5 LSB		
46 02 0C	2	00 - 7F	Chorus Parameter 6 MSB	-	
		00 - 7F	Chorus Parameter 6 LSB		
46 02 0E	2	00 - 7F	Chorus Parameter 7 MSB	-	
		00 - 7F	Chorus Parameter 7 LSB		
46 02 10	2	00 - 7F	Chorus Parameter 8 MSB	-	
		00 - 7F	Chorus Parameter 8 LSB		
46 02 12	2	00 - 7F	Chorus Parameter 9 MSB	-	
		00 - 7F	Chorus Parameter 9 LSB		
46 02 14	2	00 - 7F	Chorus Parameter 10 MSB	-	
		00 - 7F	Chorus Parameter 10 LSB		
46 02 16	1	00 - 7F	Chorus Return	<-dB...0dB...+6dB(0...96...127)	
46 02 17	1	01 - 7F	Chorus Pan	L63...C...R63	
46 02 18	1	00 - 7F	Send Chorus To Reverb	<-dB...0dB(0...127)	

TOTAL SIZE = 25 19 (HEX)

46 03 00	2	00 - 7F	Insertion-1 Type MSB	Refer to Effect Parameter List	
		00 - 7F	Insertion-1 Type LSB		
46 03 02	2	00 - 7F	Insertion-1 Parameter1 MSB	-	
		00 - 7F	Insertion-1 Parameter1 LSB		
46 03 04	2	00 - 7F	Insertion-1 Parameter2 MSB	-	
		00 - 7F	Insertion-1 Parameter2 LSB		
46 03 06	2	00 - 7F	Insertion-1 Parameter3 MSB	-	
		00 - 7F	Insertion-1 Parameter3 LSB		
46 03 08	2	00 - 7F	Insertion-1 Parameter4 MSB	-	
		00 - 7F	Insertion-1 Parameter4 LSB		
46 03 0A	2	00 - 7F	Insertion-1 Parameter5 MSB	-	
		00 - 7F	Insertion-1 Parameter5 LSB		
46 03 0C	2	00 - 7F	Insertion-1 Parameter6 MSB	-	
		00 - 7F	Insertion-1 Parameter6 LSB		
46 03 0E	2	00 - 7F	Insertion-1 Parameter7 MSB	-	
		00 - 7F	Insertion-1 Parameter7 LSB		
46 03 10	2	00 - 7F	Insertion-1 Parameter8 MSB	-	
		00 - 7F	Insertion-1 Parameter8 LSB		
46 03 12	2	00 - 7F	Insertion-1 Parameter9 MSB	-	
		00 - 7F	Insertion-1 Parameter9 LSB		
46 03 14	2	00 - 7F	Insertion-1 Parameter10 MSB	-	
		00 - 7F	Insertion-1 Parameter10 LSB		

TOTAL SIZE = 22 16 (HEX)

Address	Size	Data Range (HEX)	Parameter Name	Description	Notes
46 04 00	2	00 - 7F	Insertion-2 Type MSB	Refer to Effect Parameter List	
		00 - 7F	Insertion-2 Type LSB		
46 04 02	2	00 - 7F	Insertion-2 Parameter 1 MSB	-	
		00 - 7F	Insertion-2 Parameter 1 LSB		
46 04 04	2	00 - 7F	Insertion-2 Parameter 2 MSB	-	
		00 - 7F	Insertion-2 Parameter 2 LSB		
46 04 06	2	00 - 7F	Insertion-2 Parameter 3 MSB	-	
		00 - 7F	Insertion-2 Parameter 3 LSB		
46 04 08	2	00 - 7F	Insertion-2 Parameter 4 MSB	-	
		00 - 7F	Insertion-2 Parameter 4 LSB		
46 04 0A	2	00 - 7F	Insertion-2 Parameter 5 MSB	-	
		00 - 7F	Insertion-2 Parameter 5 LSB		
46 04 0C	2	00 - 7F	Insertion-2 Parameter 6 MSB	-	
		00 - 7F	Insertion-2 Parameter 6 LSB		
46 04 0E	2	00 - 7F	Insertion-2 Parameter 7 MSB	-	
		00 - 7F	Insertion-2 Parameter 7 LSB		
46 04 10	2	00 - 7F	Insertion-2 Parameter 8 MSB	-	
		00 - 7F	Insertion-2 Parameter 8 LSB		
46 04 12	2	00 - 7F	Insertion-2 Parameter 9 MSB	-	
		00 - 7F	Insertion-2 Parameter 9 LSB		
46 04 14	2	00 - 7F	Insertion-2 Parameter 10 MSB	-	
		00 - 7F	Insertion-2 Parameter 10 LSB		
46 04 16	2	00 - 7F	Insertion-2 Parameter 11 MSB	-	
		00 - 7F	Insertion-2 Parameter 11 LSB		
46 04 18	2	00 - 7F	Insertion-2 Parameter 12 MSB	-	
		00 - 7F	Insertion-2 Parameter 12 LSB		
46 04 1A	2	00 - 7F	Insertion-2 Parameter 13 MSB	-	
		00 - 7F	Insertion-2 Parameter 13 LSB		
46 04 1C	2	00 - 7F	Insertion-2 Parameter 14 MSB	-	
		00 - 7F	Insertion-2 Parameter 14 LSB		
46 04 1E	2	00 - 7F	Insertion-2 Parameter 15 MSB	-	
		00 - 7F	Insertion-2 Parameter 15 LSB		
46 04 20	2	00 - 7F	Insertion-2 Parameter 16 MSB	-	
		00 - 7F	Insertion-2 Parameter 16 LSB		

TOTAL SIZE = 34 22 (HEX)

46 05 00	1	00 - 09	Controller Set1 Source	PB, MW, ---, AT, FC2, FS, FC1, BC, AS1, AS2	
46 05 01	2	00	Controller Set1 Destination MSB	0 - 29	
		00 - 1D	Controller Set1 Destination LSB		
46 05 03	1	00 - 7F	Controller Set1 Depth	-64 - +63	
46 05 04	1		reserved		
46 05 05	1	00 - 09	Controller Set2 Source	PB, MW, ---, AT, FC2, FS, FC1, BC, AS1, AS2	
46 05 06	2	00	Controller Set2 Destination MSB	0 - 29	
		00 - 1D	Controller Set2 Destination LSB		
46 05 08	1	00 - 7F	Controller Set2 Depth	-64 - +63	
46 05 09	1		reserved		
46 05 0A	1	00 - 09	Controller Set3 Source	PB, MW, ---, AT, FC2, FS, FC1, BC, AS1, AS2	
46 05 0B	2	00	Controller Set3 Destination MSB	0 - 29	
		00 - 1D	Controller Set3 Destination LSB		
46 05 0D	1	00 - 7F	Controller Set3 Depth	-64 - +63	
46 05 0E	1		reserved		
46 05 0F	1	00 - 09	Controller Set4 Source	PB, MW, ---, AT, FC2, FS, FC1, BC, AS1, AS2	
46 05 10	2	00	Controller Set4 Destination MSB	0 - 29	
		00 - 1D	Controller Set4 Destination LSB		
46 05 12	1	00 - 7F	Controller Set4 Depth	-64 - +63	
46 05 13	1		reserved		
46 05 14	1	00 - 09	Controller Set5 Source	PB, MW, ---, AT,FC2, FS,FC1, BC, AS1, AS2	
46 05 15	2	00	Controller Set5 Destination MSB	0 - 29	
		00 - 1D	Controller Set5 Destination LSB		
46 05 17	1	00 - 7F	Controller Set5 Depth	-64 - +63	
46 05 18	1		reserved		
46 05 19	1	00 - 09	Controller Set6 Source	PB, MW, ---, AT,FC2, FS,FC1, BC, AS1, AS2	
46 05 1A	2	00	Controller Set6 Destination MSB	0 - 29	
		00 - 1D	Controller Set6 Destination LSB		
46 05 1C	1	00 - 7F	Controller Set6 Depth	-64 - +63	
46 05 1D	1		reserved		

TOTAL SIZE = 30 1E (HEX)

<Table 9-2>  
MIDI PARAMETER CHANGE TABLE (DRUM VOICE KEY)

Address	Size	Data Range (HEX)	Parameter Name	Description	Notes
47 ee 00	1	00-01	Element Assign	off, on	
47 ee 01	1	00-01	Wave Type	0:PresetWave 1:Voice	
47 ee 02	1	00	reserved		
47 ee 03	1	00-01	Receive Note Off	off, on	
47 ee 04	1	00-01	Assign Mode	single, multi	*1
47 ee 05	1	00-7F	Alternate Group	0:off, 1-127	
47 ee 06	2	00-7F	Wave Number MSB	1st bit6-0 → bit13-7 (User: 0-256)	
		00-7F	Wave Number LSB	2nd bit6-0 → bit6-0	
47 ee 08	3	00-7F	Voice Bank Number MSB	0-127	*1
		00-7F	Voice Bank Number LSB	0-127	*1
		00-7F	Voice Number	0-127	*1
47 ee 0B	1	01-7F	Pan	L63-C-R63	*1
47 ee 0C	1	00-7F	Random Pan Depth	0-127	
47 ee 0D	1	00-7F	Alternate Pan Depth	L64-0-R63	
47 ee 0E	1	00-7F	Reverb Send Level	0-127	*1
47 ee 0F	1	00-7F	Chorus Send Level	0-127	*1
47 ee 10	1		reserved		
47 ee 11	1	00-02	Insertion Effect Switch	thru, ins1, ins2	*1
47 ee 12	1	00-47	Output Select	0: L&R 8: asnL&R, 10: asn1&2, 11: asn3&4 64-65: asnL, asnR, 68-71: asn1-4	*1

TOTAL SIZE = 19 13 (HEX)

47 ee 20	1	00-7F	Element Level	0-127	*1
47 ee 21	1	00-7F	Level Velocity Sensitivity	-64-+63	
47 ee 22	1	00	reserved		
47 ee 23	1	00-7F	AEG Attack Time	0-127	
47 ee 24	1	00-7F	AEG Decay1 Time	0-127	
47 ee 25	1	00-7F	AEG Decay2 Time	0-126,hold	
47 ee 26	1	00	reserved		
47 ee 27	1	00	reserved		
47 ee 28	1	00	reserved		
47 ee 29	1	00-7F	AEG Decay1 Level	0-127	
47 ee 2A	1	00	reserved		
47 ee 2B	1	00	reserved		

TOTAL SIZE = 12 0C (HEX)

48 ee 00	1	10-70	Coarse Tune	-48-+48	*1
48 ee 01	1	00-7F	Fine Tune	-64-+63	*1
48 ee 02	1	00-7F	Pitch Velocity Sensitivity	-64-+63	

TOTAL SIZE = 3 03 (HEX)

49 ee 00	1	00	reserved		
49 ee 01	2	00-01 00-7F	LPF Cutoff Frequency MSB LPF Cutoff Frequency LSB	0-255	
49 ee 03	1	00-7F	LPF Cutoff Velocity Sensitivity	-64-+63	
49 ee 04	1	00-1F	LPF Resonance	0-31	
49 ee 05	1	40	reserved		
49 ee 06	2	00-01 00-7F	HPF Cutoff Frequency MSB HPF Cutoff Frequency LSB	0-255	

TOTAL SIZE = 8 08 (HEX)

4A ee 00	1	00-05	EQ Type	EQ LH, PEQ, Boost6, Boost12, Boost18, thru	
4A ee 01	1	00-1F	EQ Resonance	0-31	
4A ee 02	2	00-01 00-7F	EQ 1 Frequency MSB EQ 1 Frequency LSB	EQ L/H: 46-182, PEQ: 83-251	
4A ee 04	1	20-60	EQ 1 GAIN	-32-+32	
4A ee 05	2	00-01 00-7F	EQ 2 Frequency MSB EQ 2 Frequency LSB	EQ L/H:131-241	
4A ee 07	1	20-60	EQ 2 GAIN	-32-+32	

TOTAL SIZE = 8 08 (HEX)

ee = Element Number (00..48: C0 - C6)

\*1 When the Wave/Voice type is set to "voice", only these parameters are available.

<Table 10>  
MIDI PARAMETER CHANGE TABLE (PLUG-IN VOICE)

Address	Size	Data Range (HEX)	Parameter Name	Description	Notes
4C 70 00	1	20-7E	Voice Name1	32..126(ASCII)	
4C 70 01	1	20-7E	Voice Name2	32..126(ASCII)	
4C 70 02	1	20-7E	Voice Name3	32..126(ASCII)	
4C 70 03	1	20-7E	Voice Name4	32..126(ASCII)	
4C 70 04	1	20-7E	Voice Name5	32..126(ASCII)	
4C 70 05	1	20-7E	Voice Name6	32..126(ASCII)	
4C 70 06	1	20-7E	Voice Name7	32..126(ASCII)	
4C 70 07	1	20-7E	Voice Name8	32..126(ASCII)	
4C 70 08	1	20-7E	Voice Name9	32..126(ASCII)	
4C 70 09	1	20-7E	Voice Name10	32..126(ASCII)	
4C 70 0A	1		reserved		
4C 70 0B	1		reserved		
4C 70 0C	1	00-10	Voice Category(Main)	0..16(--Co)	Ap, Kb, Or, Gt, Ba, St, Br, Rp, Ld, Pd, Sc, Cp, Dr, Se, Me, Co
4C 70 0D	1	00-03	Voice Category(Sub)	0..3(--Sub1..Sub3)	depends on Main Category
4C 70 0E	1		reserved		
4C 70 0F	1		reserved		
4C 70 10	1		reserved		
4C 70 11	1		reserved		
4C 70 12	1		reserved		
4C 70 13	1	00-02	QED ARP Type Bank	pre1, pre2, user	
4C 70 14	1	00-7F	QED ARP Type	UpOct1 - GateCut3	
4C 70 15	1	00-01	ARP Switch	off, on	
4C 70 16	1	00-02	ARP Hold	sync-off, off, on	
4C 70 17	1	00-06	ARP Unit Multiply	50%, 66%, 75%, 100%, 133%, 150%, 200%	
4C 70 18	1	00-7F	ARP Note Limit Low	C-2..G8	
4C 70 19	1	00-7F	ARP Note Limit High	C-2..G8	
4C 70 1A	1	01-7F	ARP Velocity Limit Low	1-127	
4C 70 1B	1	01-7F	ARP Velocity Limit High	1-127	
4C 70 1C	1	00-02	ARP Key Mode	sort, thru, direct	
4C 70 1D	1	00-01	ARP Vel Mode	original, thru	
4C 70 1F	2	0000-00C8	ARP Velocity Rate MSB ARP Velocity Rate LSB	0...200%	
4C 70 20	2	0000-00C8	ARP Gate Time Rate MSB ARP Gate Time Rate LSB	0...200%	
4C 70 22	2	0001-012C	QED ARP Tempo MSB QED ARP Tempo LSB	1..300	
4C 70 24	1	00-04	CS Function Select	0=Pan&Send, 1= Tone, 2=Assign, 3=MeqOffset, 4=Volume	
4C 70 25	1	01-7F	Pan	L63..C..R63	
4C 70 26	1	00-7F	Chorus Control	-64..+63	
4C 70 27	1	00-7F	QED Decay Time	-64..+63	
4C 70 28	1	40	reserved		
4C 70 29	1	40	reserved		
4C 70 2A	1	40	reserved		
4C 70 2B	1	40	reserved		
4C 70 2C	1	40	reserved		
4C 70 2D	1	40	reserved		
4C 70 2E	1	00-7F	ASA	-64..+63	
4C 70 2F	1	00-7F	ASB	-64..+63	
4C 70 30	1	40	reserved		
4C 70 31	1	00-7F	EQ Low Gain	-64..+63	
4C 70 32	1	00-7F	EQ Low Mid Gain	-64..+63	
4C 70 33	1	00-7F	EQ High Mid Gain	-64..+63	
4C 70 34	1	00-7F	EQ High Gain	-64..+63	
4C 70 35	1	00-7F	Scene 1 Assign1	-64..+63	
4C 70 36	1	00-7F	Scene 1 Assign2	-64..+63	
4C 70 37	1	00-7F	Scene 1 Cutoff Frequency	-64..+63	
4C 70 38	1	00-7F	Scene 1 Resonance	-64..+63	
4C 70 39	1	00-7F	Scene 1 Attack Time	-64..+63	
4C 70 3A	1	00-7F	Scene 1 Release Time	-64..+63	
4C 70 3B	1	40	reserved		
4C 70 3C	1	40	reserved		
4C 70 3D	1	40	reserved		
4C 70 3E	1	40	reserved		
4C 70 3F	1	40	reserved		
4C 70 40	1	40	reserved		
4C 70 41	1	00	reserved		

TOTAL SIZE = 66 42 (HEX)

4C 00 00	1	00-7F	Volume	0-127	
4C 00 01	1		reserved		
4C 00 02	1	00-01	Same Note Number Key On Assign	single, multi	
4C 00 03	1	00-01	QED Mono/Poly Mode	mono, poly	
4C 00 04	1		reserved		
4C 00 05	1	28-58	QED Pitch Bend Range	-24-+24[semitones]	
4C 00 06	1		reserved		
4C 00 07	1		reserved		
4C 00 08	1	00-01	QED Portamento Switch	off, on	
4C 00 09	1	00-7F	QED Portamento Time	0-127	
4C 00 0A	1	01-02	Insertion Connect Type	S->L, L->S	
4C 00 0B	1	00-7F	Reverb Send	-->dB ...0dB	
4C 00 0C	1	00-7F	Chorus Send	-->dB ...0dB	

TOTAL SIZE = 13 0D (HEX)

Address	Size	Data Range (HEX)	Parameter Name	Description	Notes
4C 01 00	2	00 - 7F	Reverb Type MSB	Refer to Effect Parameter List	
		00 - 7F	Reverb Type LSB		
4C 01 02	2	00 - 7F	Reverb Parameter 1 MSB	-	
		00 - 7F	Reverb Parameter 1 LSB		
4C 01 04	2	00 - 7F	Reverb Parameter 2 MSB	-	
		00 - 7F	Reverb Parameter 2 LSB		
4C 01 06	2	00 - 7F	Reverb Parameter 3 MSB	-	
		00 - 7F	Reverb Parameter 3 LSB		
4C 01 08	2	00 - 7F	Reverb Parameter 4 MSB	-	
		00 - 7F	Reverb Parameter 4 LSB		
4C 01 0A	2	00 - 7F	Reverb Parameter 5 MSB	-	
		00 - 7F	Reverb Parameter 5 LSB		
4C 01 0C	2	00 - 7F	Reverb Parameter 6 MSB	-	
		00 - 7F	Reverb Parameter 6 LSB		
4C 01 0E	2	00 - 7F	Reverb Parameter 7 MSB	-	
		00 - 7F	Reverb Parameter 7 LSB		
4C 01 10	2	00 - 7F	Reverb Parameter 8 MSB	-	
		00 - 7F	Reverb Parameter 8 LSB		
4C 01 12	2	00 - 7F	Reverb Parameter 9 MSB	-	
		00 - 7F	Reverb Parameter 9 LSB		
4C 01 14	2	00 - 7F	Reverb Parameter 10 MSB	-	
		00 - 7F	Reverb Parameter 10 LSB		
4C 01 16	1	00 - 7F	Reverb Return	<math>\times dB...0dB...+6dB(...c96...127)</math>	
4C 01 17	1	01 - 7F	Reverb Pan	L63...C...R63	

TOTAL SIZE = 24 18 (HEX)

4C 02 00	2	00 - 7F	Chorus Type MSB	Refer to Effect Parameter List	
		00 - 7F	Chorus Type LSB		
4C 02 02	2	00 - 7F	Chorus Parameter 1 MSB	-	
		00 - 7F	Chorus Parameter 1 LSB		
4C 02 04	2	00 - 7F	Chorus Parameter 2 MSB	-	
		00 - 7F	Chorus Parameter 2 LSB		
4C 02 06	2	00 - 7F	Chorus Parameter 3 MSB	-	
		00 - 7F	Chorus Parameter 3 LSB		
4C 02 08	2	00 - 7F	Chorus Parameter 4 MSB	-	
		00 - 7F	Chorus Parameter 4 LSB		
4C 02 0A	2	00 - 7F	Chorus Parameter 5 MSB	-	
		00 - 7F	Chorus Parameter 5 LSB		
4C 02 0C	2	00 - 7F	Chorus Parameter 6 MSB	-	
		00 - 7F	Chorus Parameter 6 LSB		
4C 02 0E	2	00 - 7F	Chorus Parameter 7 MSB	-	
		00 - 7F	Chorus Parameter 7 LSB		
4C 02 10	2	00 - 7F	Chorus Parameter 8 MSB	-	
		00 - 7F	Chorus Parameter 8 LSB		
4C 02 12	2	00 - 7F	Chorus Parameter 9 MSB	-	
		00 - 7F	Chorus Parameter 9 LSB		
4C 02 14	2	00 - 7F	Chorus Parameter 10 MSB	-	
		00 - 7F	Chorus Parameter 10 LSB		
4C 02 16	1	00 - 7F	Chorus Return	<math>\times dB...0dB...+6dB(...c96...127)</math>	
4C 02 17	1	01 - 7F	Chorus Pan	L63...C...R63	
4C 02 18	1	00 - 7F	Send Chorus To Reverb	<math>\times dB...0dB(0...127)</math>	

TOTAL SIZE = 25 19 (HEX)

4C 03 00	2	00 - 7F	Insertion-1 Type MSB	Refer to Effect Parameter List	
		00 - 7F	Insertion-1 Type LSB		
4C 03 02	2	00 - 7F	Insertion-1 Parameter1 MSB	-	
		00 - 7F	Insertion-1 Parameter1 LSB		
4C 03 04	2	00 - 7F	Insertion-1 Parameter2 MSB	-	
		00 - 7F	Insertion-1 Parameter2 LSB		
4C 03 06	2	00 - 7F	Insertion-1 Parameter3 MSB	-	
		00 - 7F	Insertion-1 Parameter3 LSB		
4C 03 08	2	00 - 7F	Insertion-1 Parameter4 MSB	-	
		00 - 7F	Insertion-1 Parameter4 LSB		
4C 03 0A	2	00 - 7F	Insertion-1 Parameter5 MSB	-	
		00 - 7F	Insertion-1 Parameter5 LSB		
4C 03 0C	2	00 - 7F	Insertion-1 Parameter6 MSB	-	
		00 - 7F	Insertion-1 Parameter6 LSB		
4C 03 0E	2	00 - 7F	Insertion-1 Parameter7 MSB	-	
		00 - 7F	Insertion-1 Parameter7 LSB		
4C 03 10	2	00 - 7F	Insertion-1 Parameter8 MSB	-	
		00 - 7F	Insertion-1 Parameter8 LSB		
4C 03 12	2	00 - 7F	Insertion-1 Parameter9 MSB	-	
		00 - 7F	Insertion-1 Parameter9 LSB		
4C 03 14	2	00 - 7F	Insertion-1 Parameter10 MSB	-	
		00 - 7F	Insertion-1 Parameter10 LSB		

TOTAL SIZE = 22 16 (HEX)

4C 04 00	2	00 - 7F	Insertion-2 Type MSB	Refer to Effect Parameter List	
		00 - 7F	Insertion-2 Type LSB		
4C 04 02	2	00 - 7F	Insertion-2 Parameter 1 MSB	-	
		00 - 7F	Insertion-2 Parameter 1 LSB		
4C 04 04	2	00 - 7F	Insertion-2 Parameter 2 MSB	-	
		00 - 7F	Insertion-2 Parameter 2 LSB		
4C 04 06	2	00 - 7F	Insertion-2 Parameter 3 MSB	-	
		00 - 7F	Insertion-2 Parameter 3 LSB		
4C 04 08	2	00 - 7F	Insertion-2 Parameter 4 MSB	-	
		00 - 7F	Insertion-2 Parameter 4 LSB		

4C 04 0A	2	00 - 7F	Insertion-2 Parameter 5 MSB	Refer to Effect Parameter List	
		00 - 7F	Insertion-2 Parameter 5 LSB		
4C 04 0C	2	00 - 7F	Insertion-2 Parameter 6 MSB	-	
		00 - 7F	Insertion-2 Parameter 6 LSB		
4C 04 0E	2	00 - 7F	Insertion-2 Parameter 7 MSB	-	
		00 - 7F	Insertion-2 Parameter 7 LSB		
4C 04 10	2	00 - 7F	Insertion-2 Parameter 8 MSB	-	
		00 - 7F	Insertion-2 Parameter 8 LSB		
4C 04 12	2	00 - 7F	Insertion-2 Parameter 9 MSB	-	
		00 - 7F	Insertion-2 Parameter 9 LSB		
4C 04 14	2	00 - 7F	Insertion-2 Parameter 10 MSB	-	
		00 - 7F	Insertion-2 Parameter 10 LSB		
4C 04 16	2	00 - 7F	Insertion-2 Parameter 11 MSB	-	
		00 - 7F	Insertion-2 Parameter 11 LSB		
4C 04 18	2	00 - 7F	Insertion-2 Parameter 12 MSB	-	
		00 - 7F	Insertion-2 Parameter 12 LSB		
4C 04 1A	2	00 - 7F	Insertion-2 Parameter 13 MSB	-	
		00 - 7F	Insertion-2 Parameter 13 LSB		
4C 04 1C	2	00 - 7F	Insertion-2 Parameter 14 MSB	-	
		00 - 7F	Insertion-2 Parameter 14 LSB		
4C 04 1E	2	00 - 7F	Insertion-2 Parameter 15 MSB	-	
		00 - 7F	Insertion-2 Parameter 15 LSB		
4C 04 20	2	00 - 7F	Insertion-2 Parameter 16 MSB	-	
		00 - 7F	Insertion-2 Parameter 16 LSB		

TOTAL SIZE = 34 22 (HEX)

4C 05 00	1	00 - 09	Controller Set1 Source	PB, MW, ..., AT, FC2, FS, FC1, BC, AS1, AS2	
4C 05 01	2	00	Controller Set1 Destination MSB	0 - 29	
		00 - 1D	Controller Set1 Destination LSB		
4C 05 03	1	00 - 7F	Controller Set1 Depth	-64 - +63	
4C 05 04	1		reserved		
4C 05 05	1	00 - 09	Controller Set2 Source	PB, MW, ..., AT, FC2, FS, FC1, BC, AS1, AS2	
4C 05 06	2	00	Controller Set2 Destination	0 - 29	
		00 - 1D	Controller Set2 Destination MSB		
4C 05 08	1	00 - 7F	Controller Set2 Depth	-64 - +63	
4C 05 09	1		reserved		

TOTAL SIZE = 10 0A (HEX)

4C 10 00	1	00 - 7F	Voice Bank MSB	0..127	
4C 10 01	1	00 - 7F	Voice Bank LSB	0..127	
4C 10 02	1	00 - 7F	Voice Number	0..127	
4C 10 03	1	28 - 58	Note Shift	-24...0...+24[semitones]	
4C 10 04	1	00 - 7F	Velocity Sense Depth	0..127	
4C 10 05	1	00 - 7F	Velocity Sense Offset	0..127	
4C 10 06	1	00 - 7F	(Vibrato Rate) LFO Speed	-64..+63	
4C 10 07	1	00 - 7F	(Vibrato Depth) LFO Pitch Depth	-64..+63	
4C 10 08	1	00 - 7F	(Vibrato Delay) LFO Delay	-64..+63	
4C 10 09	1	00 - 7F	MW Filter Control	-64..+63	
4C 10 0A	1	40	reserved	0	
4C 10 0B	1	00 - 7F	MW LFO Pitch Modulation Depth	0..127	
4C 10 0C	1	00 - 7F	MW LFO Filter Modulation Depth	0..127	
4C 10 0D	1	00 - 7F	MW LFO Amplitude Modulation Depth	0..127	
4C 10 0E	1	28 - 58	CAT Pitch Control	-24..+24[semitones]	
4C 10 0F	1	00 - 7F	CAT Filter Control	-64..+63	
4C 10 10	1	40	reserved	-64..+63	
4C 10 11	1	00 - 7F	CAT LFO Pitch Modulation Depth	0..127	
4C 10 12	1	00 - 7F	CAT LFO Filter Modulation Depth	0..127	
4C 10 13	1	00 - 7F	CAT LFO Amplitude Modulation Depth	0..127	
4C 10 14	1	00 - 5F	AC1 Control Number	0..95	
4C 10 15	1	00 - 7F	AC1 Filter Control	-64..+63	
4C 10 16	1	40	reserved	-64..+63	
4C 10 17	1	00 - 7F	AC1 LFO Pitch Modulation Depth	0..127	
4C 10 18	1	00 - 7F	AC1 LFO Filter Modulation Depth	0..127	
4C 10 19	1	00 - 7F	AC1 LFO Amplitude Modulation Depth	0..127	
4C 10 1A	1	00 - 7F	Pitch EG Initial Level	-64..+63	
4C 10 1B	1	00 - 7F	Pitch EG Attack Time	-64..+63	
4C 10 1C	1	00 - 7F	Pitch EG Release Level	-64..+63	
4C 10 1D	1	00 - 7F	Pitch EG Release Time	-64..+63	
4C 10 1E	1	00 - 7F	EQ Low Gain	-64..+63(-12 - +12[dB])	
4C 10 1F	1	00 - 7F	EQ High Gain	-64..+63(-12 - +12[dB])	
4C 10 20	1	04 - 28	EQ Low Frequency	32...2.0k[Hz]	
4C 10 21	1	1C - 3A	EQ High Frequency	500...16.0k[Hz]	
4C 10 22	1	00 - 7F	HPF Cutoff Frequency	-64...0...+63	

TOTAL SIZE = 35 23 (HEX)

4C 20 00	64	00 - 7F	Plug-in Board Native Parameter	Depends on Plug-in Board	
4C 20 40	3	00 - 7F	Plug-in Board Type MSB		
		00 - 7F	Plug-in Board Type LSB		
		00 - 7F	Plug-in Board Version Number		
	43	1	reserved		

TOTAL SIZE = 68 44 (HEX)

<Table 11>  
MIDI PARAMETER CHANGE TABLE (MIX COMMON  
for Sequence Play)

Address	Size	Data Range (HEX)	Parameter Name	Description	Notes
36 00 00	1	20	reserved		
36 00 01	1	20	reserved		
36 00 02	1	20	reserved		
36 00 03	1	20	reserved		
36 00 04	1	20	reserved		
36 00 05	1	20	reserved		
36 00 06	1	20	reserved		
36 00 07	1	20	reserved		
36 00 08	1	20	reserved		
36 00 09	1	20	reserved		
36 00 0A	1		reserved		
36 00 0B	1		reserved		
36 00 0C	1		reserved		
36 00 0D	1		reserved		
36 00 0E	1		reserved		
36 00 0F	1		reserved		
36 00 10	1	10	reserved		
36 00 11	1	00 - 01	ARP MIDI Out Switch	off, on	
36 00 12	1	00 - 10	ARP MIDI Out Channel	1..16, kbd-ch	
36 00 13	1	00 - 02	ARP Type Bank	pre1, pre2, user	
36 00 14	1	00 - 7F	ARP Type	UpOct1 - GateCut3	
36 00 15	1	00 - 01	ARP Switch	off, on	
36 00 16	1	00 - 02	ARP Hold	sync-off, off, on	
36 00 17	1	00 - 06	ARP Unit Multiply	50%, 66%, 75%, 100%, 133%, 150%, 200%	
36 00 18	1	00 - 7F	ARP Note Limit Low	C-2..G8	
36 00 19	1	00 - 7F	ARP Note Limit High	C-2..G8	
36 00 1A	1	01 - 7F	ARP Velocity Limit Low	1 - 127	
36 00 1B	1	01 - 7F	ARP Velocity Limit High	1 - 127	
36 00 1C	1	00 - 02	ARP Key Mode	sort, thru, direct	
36 00 1D	1	00 - 01	ARP Vel Mode	original, thru	
36 00 1E	2	0000 - 00C8	ARP Velocity Rate MSB	0...200%	
			ARP Velocity Rate LSB		
36 00 20	2	0000 - 00C8	ARP Gate Time Rate MSB	0...200%	
			ARP Gate Time Rate LSB		
36 00 22	2		reserved		
			reserved		
36 00 24	1	00 - 04	CS Function Select	0=Pan&Send, 1=Tone, 2=Assign, 3=MeqOffset, 4=Volume	
36 00 25	1	40	reserved		
36 00 26	1	00 - 7F	Chorus Control	-64..+63	
36 00 27	1	40	reserved		
36 00 28	1	40	reserved		
36 00 29	1	40	reserved		
36 00 2A	1	40	reserved		
36 00 2B	1	40	reserved		
36 00 2C	1	40	reserved		
36 00 2D	1	40	reserved		
36 00 2E	1	00 - 7F	ASA	-64..+63	
36 00 2F	1	00 - 7F	ASB	-64..+63	
36 00 30	1	40	reserved		
36 00 31	1	00 - 7F	EQ Low Gain	-64..+63	
36 00 32	1	00 - 7F	EQ Low Mid Gain	-64..+63	
36 00 33	1	00 - 7F	EQ High Mid Gain	-64..+63	
36 00 34	1	00 - 7F	EQ High Gain	-64..+63	
36 00 35	1	00 - 7F	Scene 1 Assign1	-64..+63	
36 00 36	1	00 - 7F	Scene 1 Assign2	-64..+63	
36 00 37	1	40	reserved		
36 00 38	1	40	reserved		
36 00 39	1	40	reserved		
36 00 3A	1	40	reserved		
36 00 3B	1	40	reserved		
36 00 3C	1	40	reserved		
36 00 3D	1	40	reserved		
36 00 3E	1	40	reserved		
36 00 3F	1	40	reserved		
36 00 40	1	40	reserved		
36 00 41	1	00	reserved		
36 00 42	1	7F	reserved		
36 00 43	1	40	reserved		
36 00 44	1	00	reserved		
36 00 45	1	20	reserved		
36 00 46	1	00	reserved		
36 00 47	1	00	reserved		
36 00 48	1	00 - 5F	Assign1 Control Number	off, 1 - 95	
36 00 49	1	00 - 5F	Assign2 Control Number	off, 1 - 95	
36 00 4A	1	00 - 5F	BC Control Number	off, 1 - 95	
36 00 4B	1	00 - 5F	FC2 Control Number	off, 1 - 95	
36 00 4C	1	00 - 5F	FC1 Control Number	off, 1 - 95	
36 00 4D	1	00 - 7F	Voice Insertion Effect Part	0 - 15: Part1...16 96 - 98: PB Part1, 2, 3 127: off	
36 00 4E	1		reserved		
36 00 4F	1	00 - 7F	InsEF Plug-in Part	0 - 15: Part1...16 64: PartAD 97 - 98: PB Part2,3 127: off	
36 00 50	1	00 - 01	A/D Input Mode	L mono, R mono, L+R mono, stereo	Fixed at "mono" when using the Analog Input.

Address	Size	Data Range (HEX)	Parameter Name	Description	Notes
36 00 51	1	00 - 7F	A/D Part Volume	0 - 127	
36 00 52	1	01 - 7F	A/D Part Pan	L63 - C - R63	
36 00 53	1	00 - 7F	A/D Part Reverb Send	0 - 127	
36 00 54	1	00 - 7F	A/D Part Chorus Send	0 - 127	
36 00 55	1	00 - 7F	A/D Part Variation Send	0 - 127	
36 00 56	1	00 - 7F	A/D Part Dry Level	0 - 127	
36 00 57	1	00 - 71	A/D Part Output Select	0: L&R 8: asnL&R, 10: asn1&2, 11: asn3&4 64 - 65: asnL, asnR, 68 - 71: asn1 - 4	

TOTAL SIZE = 88 58 (HEX)

36 01 00	2	00 - 7F	Reverb Type MSB	Refer to Effect Parameter List	
		00 - 7F	Reverb Type LSB		
36 01 02	2	00 - 7F	Reverb Parameter 1 MSB	-	
		00 - 7F	Reverb Parameter 1 LSB		
36 01 04	2	00 - 7F	Reverb Parameter 2 MSB	-	
		00 - 7F	Reverb Parameter 2 LSB		
36 01 06	2	00 - 7F	Reverb Parameter 3 MSB	-	
		00 - 7F	Reverb Parameter 3 LSB		
36 01 08	2	00 - 7F	Reverb Parameter 4 MSB	-	
		00 - 7F	Reverb Parameter 4 LSB		
36 01 0A	2	00 - 7F	Reverb Parameter 5 MSB	-	
		00 - 7F	Reverb Parameter 5 LSB		
36 01 0C	2	00 - 7F	Reverb Parameter 6 MSB	-	
		00 - 7F	Reverb Parameter 6 LSB		
36 01 0E	2	00 - 7F	Reverb Parameter 7 MSB	-	
		00 - 7F	Reverb Parameter 7 LSB		
36 01 10	2	00 - 7F	Reverb Parameter 8 MSB	-	
		00 - 7F	Reverb Parameter 8 LSB		
36 01 12	2	00 - 7F	Reverb Parameter 9 MSB	-	
		00 - 7F	Reverb Parameter 9 LSB		
36 01 14	2	00 - 7F	Reverb Parameter 10 MSB	-	
		00 - 7F	Reverb Parameter 10 LSB		
36 01 16	1	00 - 7F	Reverb Return	-<dB...0dB...+6dB(...c96...127)	
36 01 17	1	01 - 7F	Reverb Pan	L63...C...R63	

TOTAL SIZE = 24 18 (HEX)

36 02 00	2	00 - 7F	Chorus Type MSB	Refer to Effect Parameter List	
		00 - 7F	Chorus Type LSB		
36 02 02	2	00 - 7F	Chorus Parameter 1 MSB	-	
		00 - 7F	Chorus Parameter 1 LSB		
36 02 04	2	00 - 7F	Chorus Parameter 2 MSB	-	
		00 - 7F	Chorus Parameter 2 LSB		
36 02 06	2	00 - 7F	Chorus Parameter 3 MSB	-	
		00 - 7F	Chorus Parameter 3 LSB		
36 02 08	2	00 - 7F	Chorus Parameter 4 MSB	-	
		00 - 7F	Chorus Parameter 4 LSB		
36 02 0A	2	00 - 7F	Chorus Parameter 5 MSB	-	
		00 - 7F	Chorus Parameter 5 LSB		
36 02 0C	2	00 - 7F	Chorus Parameter 6 MSB	-	
		00 - 7F	Chorus Parameter 6 LSB		
36 02 0E	2	00 - 7F	Chorus Parameter 7 MSB	-	
		00 - 7F	Chorus Parameter 7 LSB		
36 02 10	2	00 - 7F	Chorus Parameter 8 MSB	-	
		00 - 7F	Chorus Parameter 8 LSB		
36 02 12	2	00 - 7F	Chorus Parameter 9 MSB	-	
		00 - 7F	Chorus Parameter 9 LSB		
36 02 14	2	00 - 7F	Chorus Parameter 10 MSB	-	
		00 - 7F	Chorus Parameter 10 LSB		
36 02 16	1	00 - 7F	Chorus Return	-<dB...0dB...+6dB(...c96...127)	
36 02 17	1	01 - 7F	Chorus Pan	L63...C...R63	
36 02 18	1	00 - 7F	Send Chorus To Reverb	-<dB...0dB(0...127)	

TOTAL SIZE = 25 19 (HEX)

36 03 00	2	00 - 7F	Variation Type MSB (for Performance)	Refer to Effect Parameter List	
		00 - 7F	Variation Type LSB		
36 03 02	2	00 - 7F	Variation Parameter1 MSB	-	
		00 - 7F	Variation Parameter1 LSB		
36 03 04	2	00 - 7F	Variation Parameter2 MSB	-	
		00 - 7F	Variation Parameter2 LSB		
36 03 06	2	00 - 7F	Variation Parameter3 MSB	-	
		00 - 7F	Variation Parameter3 LSB		
36 03 08	2	00 - 7F	Variation Parameter4 MSB	-	
		00 - 7F	Variation Parameter4 LSB		
36 03 0A	2	00 - 7F	Variation Parameter5 MSB	-	
		00 - 7F	Variation Parameter5 LSB		
36 03 0C	2	00 - 7F	Variation Parameter6 MSB	-	
		00 - 7F	Variation Parameter6 LSB		
36 03 0E	2	00 - 7F	Variation Parameter7 MSB	-	
		00 - 7F	Variation Parameter7 LSB		
36 03 10	2	00 - 7F	Variation Parameter8 MSB	-	
		00 - 7F	Variation Parameter8 LSB		
36 03 12	2	00 - 7F	Variation Parameter9 MSB	-	
		00 - 7F	Variation Parameter9 LSB		
36 03 14	2	00 - 7F	Variation Parameter10 MSB	-	
		00 - 7F	Variation Parameter10 LSB		
36 03 16	2	00 - 7F	Variation Parameter11 MSB	-	
		00 - 7F	Variation Parameter11 LSB		
36 03 18	2	00 - 7F	Variation Parameter12 MSB	-	
		00 - 7F	Variation Parameter12 LSB		

Address	Size	Data Range (HEX)	Parameter Name	Description	Notes
		00 - 7F	Variation Parameter12 LSB		
36 03 1A 2		00 - 7F	Variation Parameter13 MSB		
		00 - 7F	Variation Parameter13 LSB		
36 03 1C 2		00 - 7F	Variation Parameter14 MSB	Refer to Effect Parameter List	
		00 - 7F	Variation Parameter14 LSB		
36 03 1E 2		00 - 7F	Variation Parameter15 MSB		
		00 - 7F	Variation Parameter15 LSB		
36 03 20 2		00 - 7F	Variation Parameter16 MSB		
		00 - 7F	Variation Parameter16 LSB		
36 03 22 1		00 - 7F	Variation Return	~<dB...>dB...+6dB(...c96...127)	
36 03 23 1		01 - 7F	Variation Pan	L63...C...R63	
36 03 24 1		00 - 7F	Send Variation To Reverb	~<dB...>dB(0...127)	
36 03 25 1		00 - 7F	Send Variation To Chorus	~<dB...>dB(0...127)	

TOTAL SIZE = 38 26 (HEX)

36 10 00 1		34 - 4C	EQ Gain1	-12 - +12[dB]	
36 10 01 1		04 - 28	EQ Frequency1	32 - 2000[Hz]	
36 10 02 1		01 - 78	EQ Q1	0.1 - 12.0	
36 10 03 1		00 - 01	EQ Shape1	shelv, peak	
36 10 04 1		34 - 4C	EQ Gain2	-12 - +12[dB]	
36 10 05 1		0E - 36	EQ Frequency2	100 - 10.0[kHz]	
36 10 06 1		01 - 78	EQ Q2	0.1 - 12.0	
36 10 07 1		01	reserved		
36 10 08 1		34 - 4C	EQ Gain3	-12 - +12[dB]	
36 10 09 1		0E - 36	EQ Frequency3	100 - 10.0[kHz]	
36 10 0A 1		01 - 78	EQ Q3	0.1 - 12.0	
		1	Not Used		
36 10 0C 1		34 - 4C	EQ Gain4	-12 - +12[dB]	
36 10 0D 1		0E - 36	EQ Frequency4	100 - 10.0[kHz]	
36 10 0E 1		01 - 78	EQ Q4	0.1 - 12.0	
		1	Not Used		
36 10 10 1		34 - 4C	EQ Gain5	-12 - +12[dB]	
36 10 11 1		1C - 3A	EQ Frequency5	0.5 - 16.0[kHz]	
36 10 12 1		01 - 78	EQ Q5	0.1 - 12.0	
36 10 13 1		00 - 01	EQ Shape5	shelv, peak	

TOTAL SIZE = 20 14 (HEX)

36 20 00 16		00 - 7F	Plug-in Board Native System Parameter	(for InsEF Plug-in)	
36 20 10 48		00 - 7F	Plug-in Board Native Parameter	(for InsEF Plug-in)	
36 20 40 3		00 - 7F	Plug-in Board Type MSB	(for InsEF Plug-in)	
		00 - 7F	Plug-in Board Type LSB		
		00 - 7F	Plug-in Board Version Number		
		43 1	reserved		

TOTAL SIZE = 68 44 (HEX)

## MIDI PARAMETER CHANGE TABLE (MIX PART for Sequence Play)

Address	Size	Data Range (HEX)	Parameter Name	Description	Notes
37 pp 00 1		00 - 7F	Bank Select MSB	0 - 127	
37 pp 01 1		00 - 7F	Bank Select LSB	0 - 127	
37 pp 02 1		00 - 7F	Program Number	1 - 128	
37 pp 03 1		00 - 0F, 7F	Receive Channel	1..16, off(7F)	
37 pp 04 1		00 - 01	Part Mode	mono, poly	
37 pp 05 1		01 - 7F	Velocity Limit Low	1 - 127	
37 pp 06 1		01 - 7F	Velocity Limit High	1 - 127	
37 pp 07 1		00 - 7F	Note Limit Low	C-2 - G8	
37 pp 08 1		00 - 7F	Note Limit High	C-2 - G8	
37 pp 09 1		10 - 58	Pitch Bend Range Upper	-48 - +24 (PB Part: -24 - +24)	
37 pp 0A 1		10 - 58	Pitch Bend Range Lower	-48 - +24	
37 pp 0B 1		00 - 7F	Velocity Sense Depth	0 - 127	
37 pp 0C 1		00 - 7F	Velocity Send Offset	0 - 127	
37 pp 0D 1		00 - 7F	Volume	0 - 127	
37 pp 0E 1		01 - 7F	Pan	L63 - C - R63	
37 pp 0F 1			reserved		
37 pp 10 2		00 - 0F, 00 - 0F	Detune MSB, Detune LSB	-12.8 - +12.7[Hz], 1st bit3-0 → bit7-4, 2nd bit3-0 → bit3-0	
37 pp 12 1		00 - 7F	Reverb Send	0 - 127	
37 pp 13 1		00 - 7F	Chorus Send	0 - 127	
37 pp 14 1		00 - 7F	Variation Send	0 - 127	
37 pp 15 1		00 - 7F	Dry Level	0 - 127	
37 pp 16 1		28 - 58	Note Shift	-24 - +24[semitones]	
37 pp 17 1		00 - 7F	Filter Cutoff Frequency	-64 - +63	
37 pp 18 1		00 - 7F	Filter Resonance/Width	-64 - +63	
37 pp 19 1			reserved		
37 pp 1A 1		00 - 01	Portamento Switch	off, on	
37 pp 1B 1		00 - 7F	Portamento Time	0 - 127	
37 pp 1C 1		00 - 01	Portamento Mode	fingered, fulltime	
37 pp 1D 1			reserved		
37 pp 1E 1		00 - 7F	Output Select	0: L&R, 8: asnL&R, 10: asn1&2, 11: asn3&4, 64 - 65: asnL, asnR, 68 - 71: asn1 - 4, 127: drum(or L&R)	L&R on parts 17-32
37 pp 1F 1		00 - 7F	reserved, Arpeggio Sw, Receive Control Change, Receive Bank Select, Receive Program Change, Receive AT, Receive PB	bit0: reserved, bit1: Arpeggio Sw off, on, bit2: off, on Control Change, bit3: off, on Bank Select, bit4: off, on Program Change, bit5: off, on AT, bit6: off, on PB	
37 pp 20 1		00 - 7F	Receive Volume/Expression, Receive Pan, Receive Sustain/Sostenute, Receive MW	bit0: off, on Volume/Expression, bit1: off, on Pan, bit2: reserved, bit3: off, on Sustain/Sostenute, bit4: reserved, bit5: off, on MW, bit6: reserved	
37 pp 21 1		00 - 7F	Receive FC2, Receive FS, Receive FC1, Receive BC, Receive AS1, Receive AS2	bit0: off, on FC2, bit1: off, on FS, bit2: off, on FC1, bit3: off, on BC, bit4: off, on AS1, bit5: off, on AS2, bit6: reserved	
37 pp 22 1		00 - 7F	AEG Decay2 Level (EG Sustain Level)	-64 - +63	
37 pp 23 1		00 - 7F	AEG Attack Time (EG Attack Time)	-64 - +63	
37 pp 24 1		00 - 01	Voice Pan on/off	off, on	
37 pp 25 1		00 - 7F	AEG Decay2 Time (EG Decay Time)	-64 - +63	
37 pp 26 1		00 - 7F	AEG Release Time (EG Release Time)	-64 - +63	
37 pp 27 1		00 - 7F	FEG Decay2 Level (EG Sustain Level)	-64 - +63	
37 pp 28 1		00 - 7F	FEG Attack Time (EG Attack Time)	-64 - +63	
37 pp 29 1			reserved		
37 pp 2A 1		00 - 7F	FEG Decay2 Time (EG Decay Time)	-64 - +63	
37 pp 2B 1		00 - 7F	FEG Release Time (EG Release Time)	-64 - +63	
37 pp 2C 1		00 - 7F	FEG DEPTH	-64 - +63	

TOTAL SIZE = 45 2D (HEX)

- pp = part number  
00 - 0F Part 1 - 16 (Normal, Drum)  
60 Part Plug-in 1 (User, Preset, Direct)  
61 Part Plug-in 2 (User, Preset, Direct)  
62 Part Plug-in 3 (User, Preset, Direct)  
10 - 1F Multi Plug-in Board Part (Not included in the Mixing setup)

Function...	Transmitted	Recognized	Remarks
Basic Channel      Default Changed	1 - 16 X	X X	Memorized
Mode	Default Messages Altered X X *****	X X X	
Note Number : True voice	0 - 127 *****	X X	
Velocity	Note ON      O 9nH,v=1-127 Note OFF     X 9nH,v=0	X X	
After Touch	Key's      O Ch's        O	X X	
Pitch Bend	O	X	
Control Change      0-121	O	X	
Prog Change      : True #	O 0 - 127 *****	X	
System Exclusive	O	X	
Common      : Song Pos. : Song Sel. : Tune	X X X	X X X	
System      : Clock Real Time   : Commands	O            *2 O            *2	O            *1,*2 O            *2	
Aux      : All Sound Off : Reset All Cntrls : Local ON/OFF Mes-     : All Notes OFF sages    : Active Sense : Reset	O O O O X X	X X X X X X	
Notes:	*1 if MIDI Sync is midi *2 if MIDI Control is on		



Function...	Transmitted	Recognized	Remarks
Basic Channel Default Changed	1 - 16 1 - 16	1 - 16 1 - 16	Memorized
Mode Default Messages Altered	3 X *****	1 1 - 4(m=1) *2 X	Memorized
Note Number : True voice	0 - 127 *****	0 - 127 0 - 127	Transpose
Velocity Note ON Note OFF	O 9nH,v=1-127 X 9nH,v=0	O v=1-127 X	
After Touch Key's Ch's	X O	X O	*1
Pitch Bend	O	O	*1
Control Change 0,32 1,7,10,11 6,38 64 65 66 71-75 91,93 96-97 100-101 1-95	O O X O X X O O X X O	O O O O O O O O O O O	*1 *1 *1 *1 *1 *1 *1 *1 *1 *1 *1 *1
Prog Change : True #	O 0 - 127 *****	O 0 - 127 0 - 127	
System Exclusive	O	O	
Common : Song Pos. : Song Sel. : Tune	X X X	X X X	
System : Clock Real Time : Commands	X X	O X	
Aux : All Sound Off : Reset All Cntrls : Local ON/OFF Mes- : All Notes OFF sages: Active Sense : Reset	X X X X O X	O (120,126,127) O (121) X O (123-125) O X	

Notes: \*1 receive if switch is on.  
 \*2 m is always treated as "1" regardless of its value.