

YAMAHA

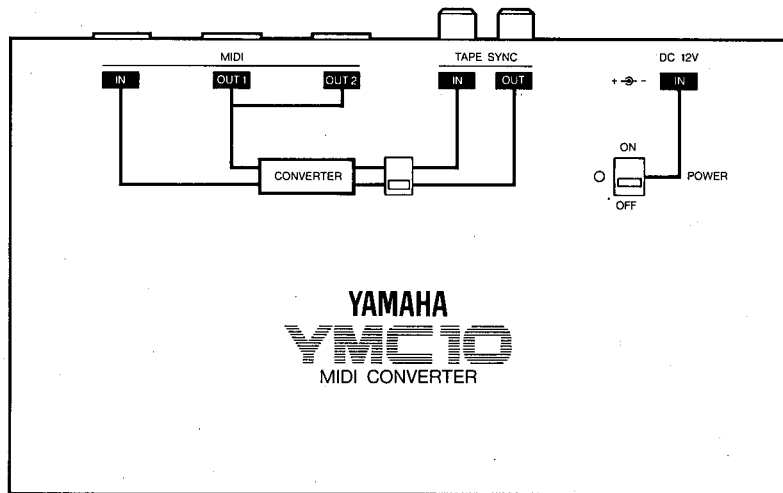

YMC10

MIDI CONVERTER

OWNER'S MANUAL

CONTENTS

PRECAUTIONS	2
FUNCTION AND FEATURES OF THE YAMAHA MIDI CONVERTER YMC10	4
DIAGRAM OF THE YMC10	5
HOW TO USE THE YMC10	7
SYNCHRONIZED PLAYBACK · RECORDING	11
YMC10 CONVERSION INFORMATION	13
SPECIFICATIONS	15
RELATED EQUIPMENT	16
BLOCK DIAGRAM	17

PRECAUTIONS

LOCATION

Avoid placing the YMC10 in direct sunlight or close to a source of heat. Also, avoid locations in which it is likely to be subjected to vibration, excessive dust, cold or moisture.

HANDLING

Avoid applying excessive force to the switches, dropping or rough handling.

CLEANING

Use only a dry soft cloth. Never use solvents (such as benzine or thinner) since they can melt or discolor the finish.

ELECTROMAGNET FIELDS

Computer circuitry is also sensitive to electromagnetic radiation. Television sets, as well as radio receivers, transmit-

ters and transceivers, and wireless microphone or intercom systems are all potential sources of such radiation, and should be kept at least several feet from the YMC10 to avoid possible interference, both to and from the YMC10.

CONNECTION

Turn off all power before connecting the YMC10 to other equipment, and disconnect all cables before moving the YMC10.

DO NOT ATTEMPT TO OPEN THE CASE

There are no user-serviceable parts inside.

MIDI CABLES

Use cables conforming to the MIDI standard. Cables are limited to 15 m. If you use a longer cable, there is a possibility of the waveform degrading, and trouble resulting.

POWER SUPPLY

The YMC10 power supply must be DC +12V. Please use the included PA1 AC adaptor. If you use other AC adaptors, problems may result.

BE CAREFUL OF THE AC CORD

To avoid shorting or breaking the cord, when you unplug the AC adaptor, grasp the adaptor, not the cord. When you will not be using it for a long time, it is a good idea to unplug the AC adaptor.

- The AC adaptor will differ according to the voltage in your area. Please check that you have the correct one.

ELECTRICAL STORMS

If there is danger of an electrical storm (lightening), immediately unplug the AC adaptor from the wall socket.

KEEP THIS OWNERS MANUAL

For future reference, keep its manual in a safe place with the guarantee.

FUNCTION AND FEATURES OF THE YAMAHA MIDI CONVERTER YMC10

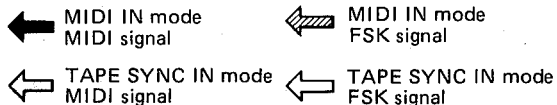
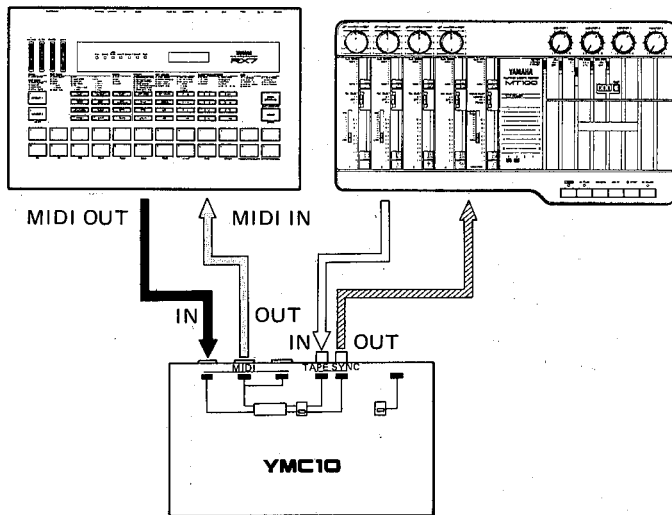

- When making multi-track recordings using a MIDI equipped RX Digital Rhythm Programmer or QX Digital Sequence Recorder, the YMC10 converts MIDI synchronization signals into an FSK tape sync signal. This tape sync signal is recorded on one of the tracks of the multi-track recorder. When you playback the tape, the YMC10 will convert this tape sync signal back into MIDI data, and synchronize the MIDI rhythm machine or sequencer with the performance on tape.
- For high reliability, the tape sync uses an FSK (Frequency Shift Keying) signal.
- The tempo range is from $J = 25$ to $J = 300$.
- When in MIDI IN mode, the MIDI OUT jacks function as MIDI THRU.

DIAGRAM OF THE YMC10

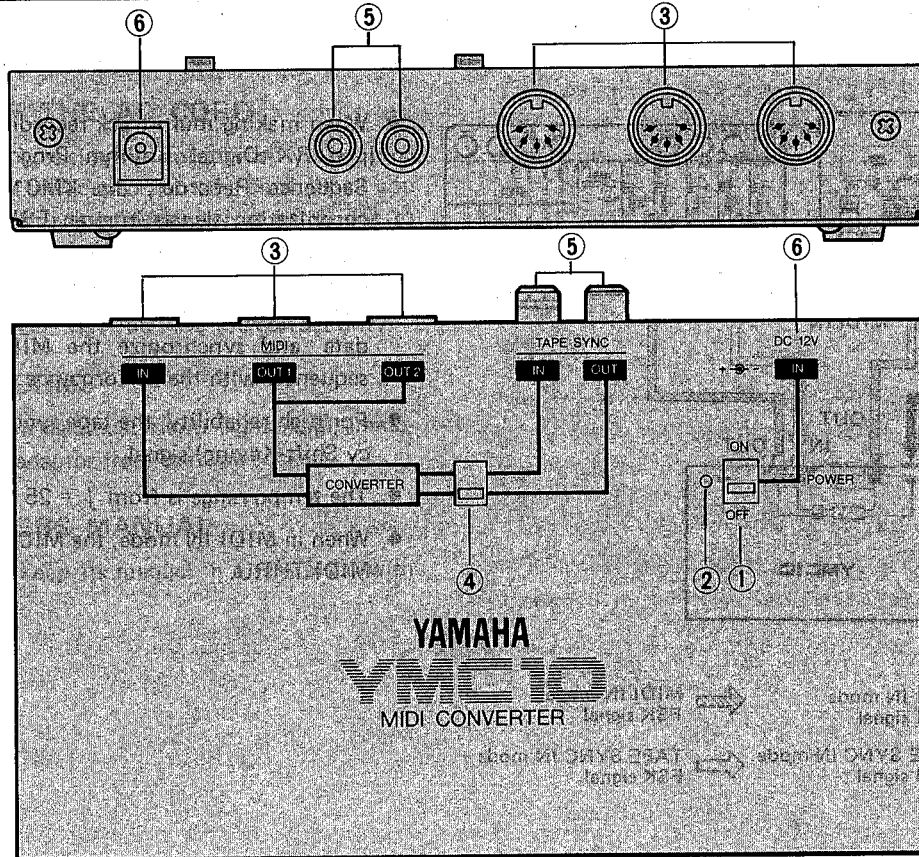

1 POWER SWITCH

This turns the unit on. (Check connections first.)

2 POWER INDICATOR

When the power switch is on, the LED will be lit.

3 MIDI CONNECTORS

These send and receive MIDI signals.

IN MIDI input jack

When the YMC10 is in MIDI IN mode, signals from the sequencer or rhythm machine are received here.

OUT 1, 2 MIDI output jacks

When the YMC10 is in TAPE IN mode, the tape sync signals are converted into MIDI signals and sent from these jacks. Connect these jacks to the MIDI device you want to synchronize with the tape. OUT 1, 2 both send the same signals.

When the YMC10 is in MIDI IN mode, the two MIDI OUT jacks function as MIDI THRU jacks.

4 MODE SELECT SWITCH

This selects MIDI IN mode or TAPE IN mode. In MIDI IN mode, MIDI start, continue, timing clock and stop signals are converted into FSK tape sync signals.

When the YMC10 is in TAPE IN mode, it will receive FSK tape sync signals coming into the TAPE IN jack, and will convert them to MIDI start, timing clock and stop signals.

5 TAPE SYNC JACKS

Input and output jacks for the tape sync signal.

OUT

When in MIDI IN mode, FSK tape sync signals are sent from this jack.

IN

When in TAPE IN mode, the recorded tape sync signal comes into this jack.

6 DC 12V JACK: PA1 (B,C)

Connect the PA1 (B,C) AC adaptor (included) to this jack. Use only the PA1 (B,C) AC adaptor.

HOW TO USE THE YMC10

1. SYNCHRONIZE A TAPE WITH A RHYTHM MACHINE

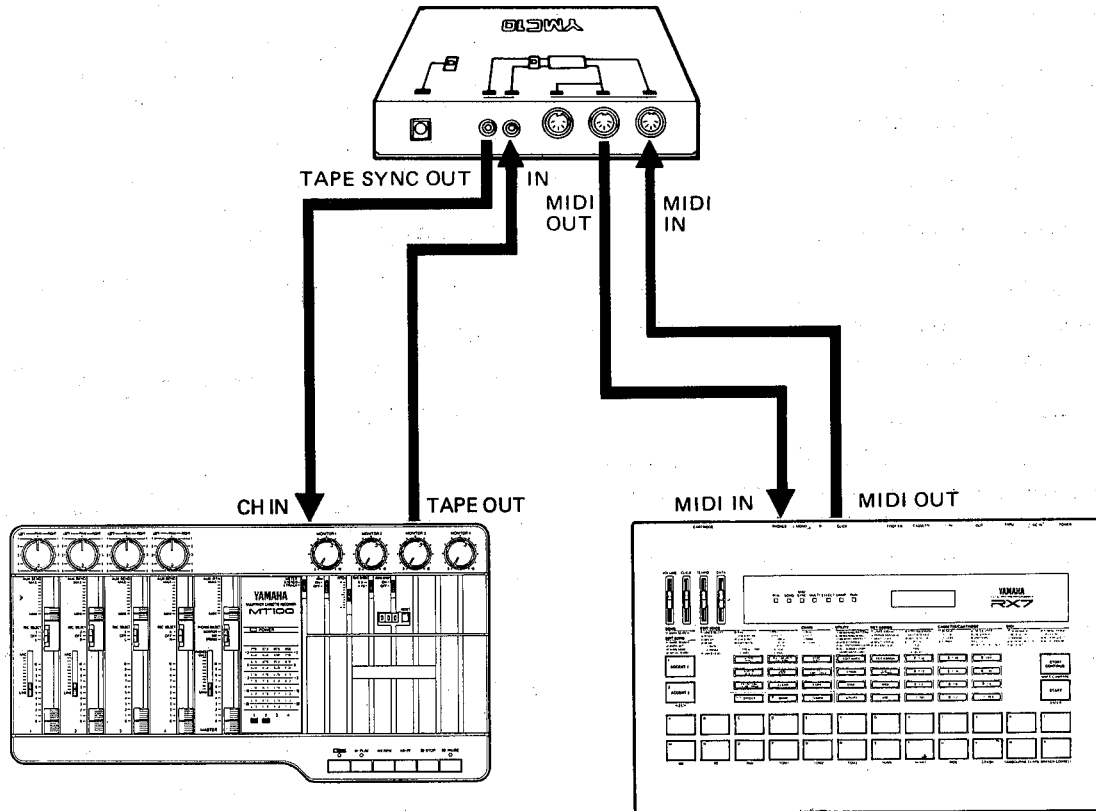

RECORDING THE SYNC TRACK

- 1 Connect a MIDI rhythm machine (such as the RX7) to the YMC10 and multi-track tape recorder (such as the MT100) as shown.
- 2 Set the YMC10 mode switch to MIDI IN.
- 3 Begin recording on tape (track 1), and start the RX7.

CAUTION

- When recording the sync signal, set the recording volume on the MT100 so that the MT100 level meter will read about 0VU.
- When in MIDI IN mode, there will always be a steady tone sent from the TAPE OUT jack. When the song begins, the steady tone will change to a warble, and when the song is over, it will change back to a steady tone. There is no need to listen to this, but it can be a useful checkpoint.

SYNCHRONIZED PLAYBACK

- 1 Set the YMC10 mode switch to TAPE IN.
- 2 Set the RX7 sync to MIDI CLOCK. (See the RX7 owners manual.) Play the tape, and the RM7 will begin playing in sync with the tape.
(If you use the MT100 pitch control to change the tape speed, the RX7 tempo will change accordingly.)

CAUTION

- Before playback, be sure to rewind the tape to a bit before the point where the tape sync signal starts.

When using other MTR equipment to record and reproduce the sync signal, be sure the recording level is correct. Otherwise, it may not sync. Also, some equipment may reverse the phase of the sync signal, making synchronization impossible.

2. MULTITRACK RECORDING WITH SYNCHRONIZED MIDI EQUIPMENT

Here we will explain a multitrack recording system using the Yamaha multitrack recorder MT100 and MIDI equipment.

NOTE: For a detailed explanation of multitrack recording, see the manuals of the MT100.

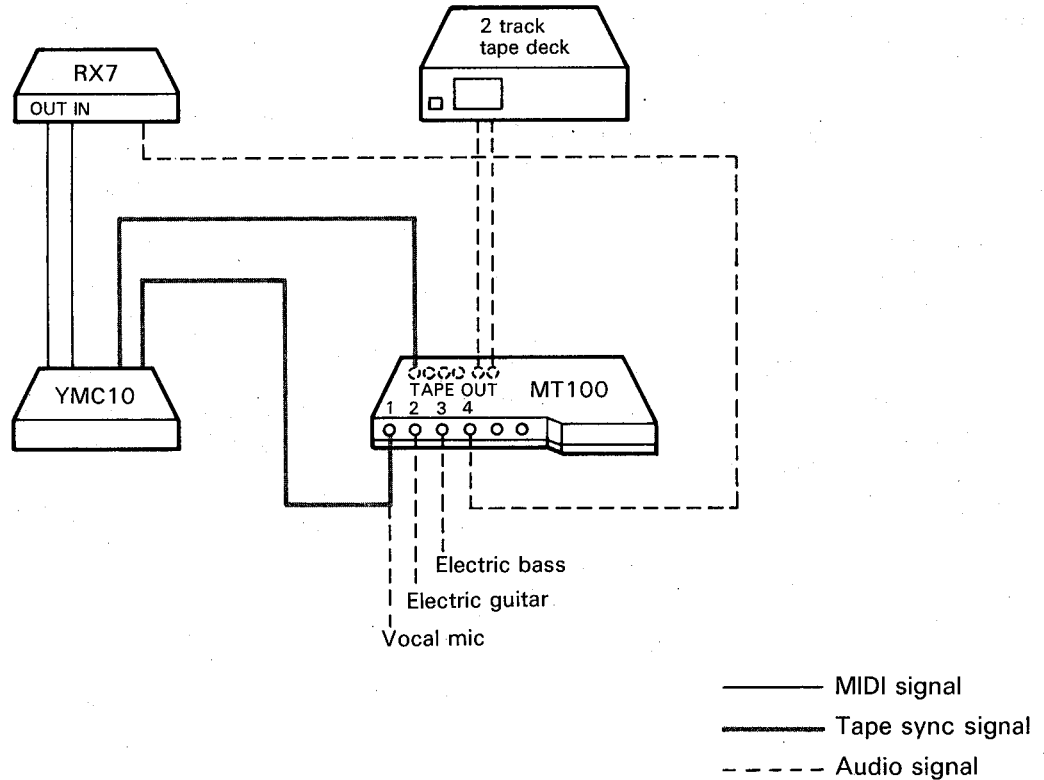

PREPARATIONS

- 1 First, plan your recording.
Let's record the tape sync signal on track 1 of the MT100, and use this tape sync signal to synchronize a sequencer and a rhythm machine to the tape. Then, we will mix everything down on a 2 track cassette deck, using the MT100's mixing function.

- 2 Connect the components of the system as shown.
Connect the TAPE SYNC IN, OUT of the YMC10 to the TAPE OUT, CH IN of the MT100.
- 3 Input the rhythm patterns into the RX7.

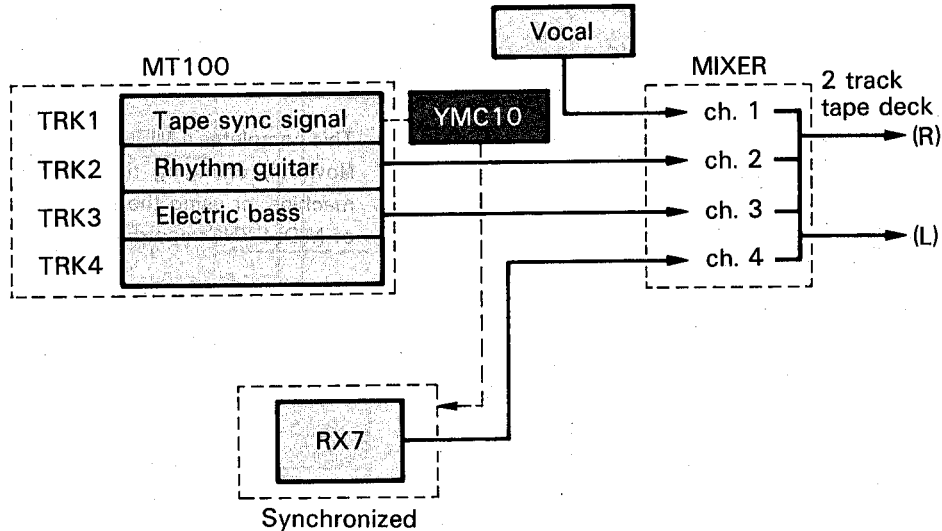

SYNCHRONIZED PLAYBACK · RECORDING

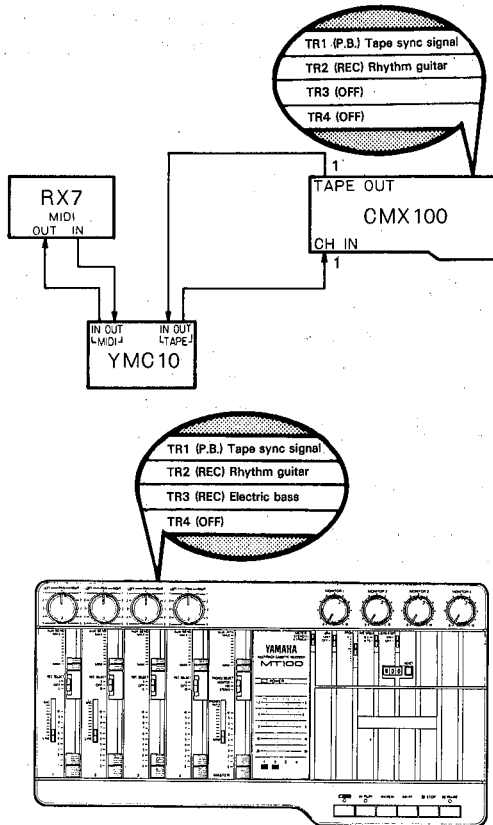

1. Play the RX7 and record the tape sync signal from the YMC10.
2. Rewind the tape, and record rhythm guitar on track 2 of the MT100, listening to the rhythm machine as a guide. (Be careful not to erase the sync signal on track 1.)
3. Record electric bass on track 3 of the MT100.

CAUTION

If you pause or stop the tape during synchronized playback, be sure to rewind to the beginning of the song and re-synchronize from the beginning. When you re-start the tape, the MIDI devices will start again from the beginning.

This completes a MIDI-synchronized multi-track recording. Now, try changing the rhythm patterns of the rhythm machine, or using the sequencer. Explore the possibilities of MIDI SYNC recording.

- 4 While adding a vocal part, mix down the completed recording onto a two-track cassette. Playback the MT100, and the RX7 will play along in sync

with the rhythm guitar and electric bass on tracks 2 and 3. While adding a vocal part, mix this down using the MT100's mixing function.

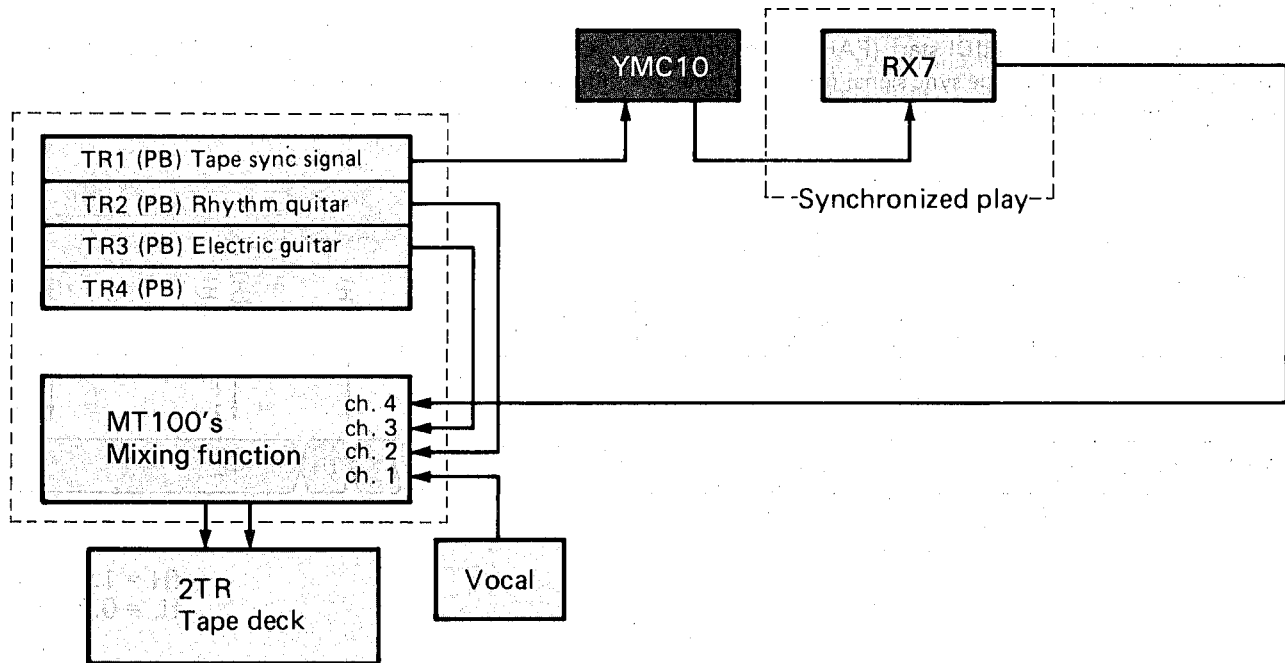

YMC10 CONVERSION INFORMATION

Here is a detailed explanation of how the YMC10 actually works.

■ MIDI IN mode

Once the YMC10 receives a MIDI start (FAH) or continue (FBH) signal, it will send a tape sync signal (fH) every time it receives a timing clock (F8H).

Once it receives a MIDI stop signal (FCH), it will ignore further timing clock signals. (the output from the TAPE SYNC OUT jack changes back to a steady tone)

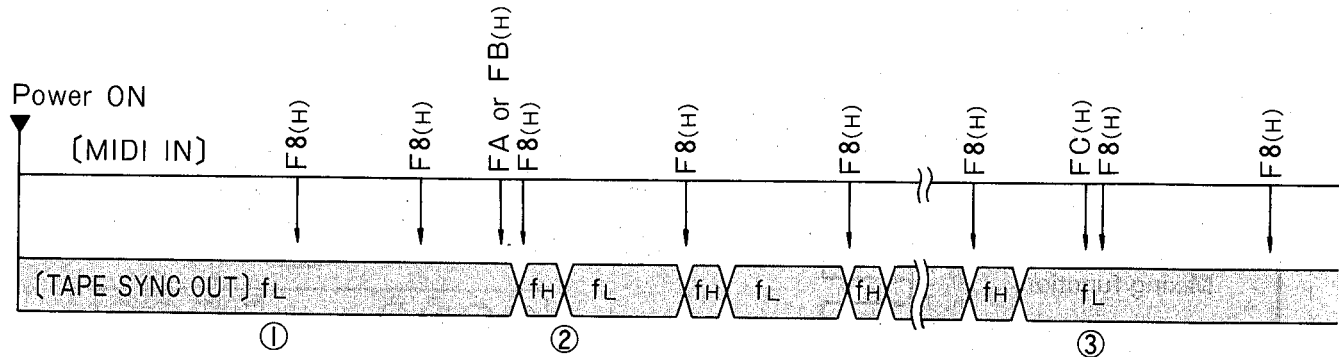

fH = 1.953KHz
fL = 0.977KHz

■ TAPE SYNC IN mode

When the YMC10 receives the first tape sync signal (fH), it will send a MIDI start (FAH) and timing clock (F8H). After that, every time it receives a tape sync signal (fH), it will send a MIDI timing clock (F8H). If the tape stops, or no more tape sync signals are received, it will send a stop (FCH) signal.

From this you can see that if you stop (or pause) and restart the tape in the middle of synchronized playback, the MIDI sequencers and rhythm machines will start again from the beginning. The YMC10 tape sync is not compatible with tape sync signals of other MIDI converters. Also, to ensure perfect synchronization, use the same YMC10 for recording and playback.

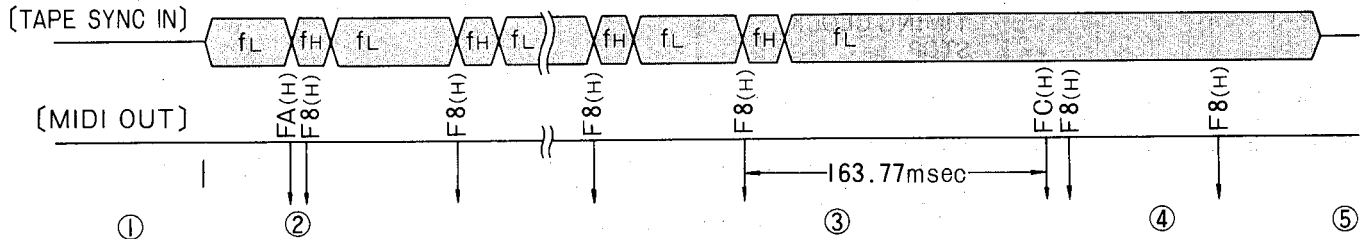

fH = 1.953KHz
fL = 0.977KHz

SPECIFICATIONS

MIDI RECEIVE DATA	START, CONTINUE TIMING CLOCK STOP
TAPE SYNC OUT	TAPE SYNC CLOCK (FSK SIGNAL): fH = 1.953KHz, fL = 0.977KHz OUTPUT LEVEL -10 dB (245 mV)
TAPE SYNC IN	TAPE SYNC CLOCK (FSK SIGNAL): INPUT LEVEL -20 dB (78 mV) ~ 0 dB (775 mV)
MIDI TRANSMIT DATA	START TIMING CLOCK STOP
TEMPO RANGE	Min. ♩ = 25 ~ Max. ♩ = 300
SWITCHES	POWER SWITCH ON/OFF (LED INDICATOR) MODE SWITCH MIDI MODE/TAPE SYNC IN MODE SWITCH
INPUT JACKS	MIDI IN x 1 OUT x 2 TAPE SYNC IN x 1 OUT x 1 DC (12V) IN x 1
DIMENSIONS (W x D x H)	190 mm x 116 mm x 38.8 mm (7-½" x 4-½" x 1-½")
WEIGHT	610 g (13.4 lb)
INCLUDED ITEM	AC ADAPTOR - PA1 (B,C)

RELATED EQUIPMENT

MT100

The MT100 will allow you to produce multi-track master tapes which approach the quality of those produced on much more costly recording systems. With dbx noise reduction systems built-in, you always have clean, quality recording.

* dbx is a trade mark of dbx Incorporated.

RM 602

The RM602 is a lightweight and compact 6-in/2-out mixing console offering exceptional sound quality and a wide range of control features. It has been designed specifically to enhance the performance of a small home recording studio.

MT100

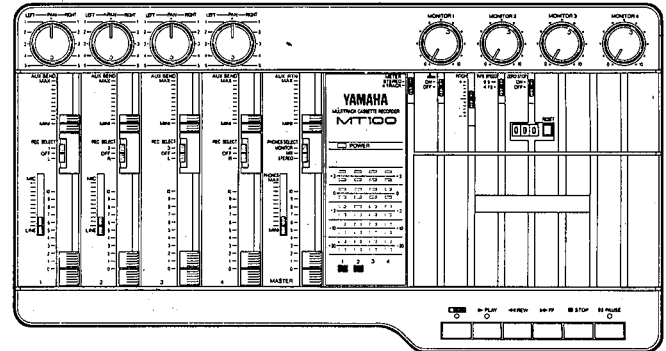

BLOCK DIAGRAM

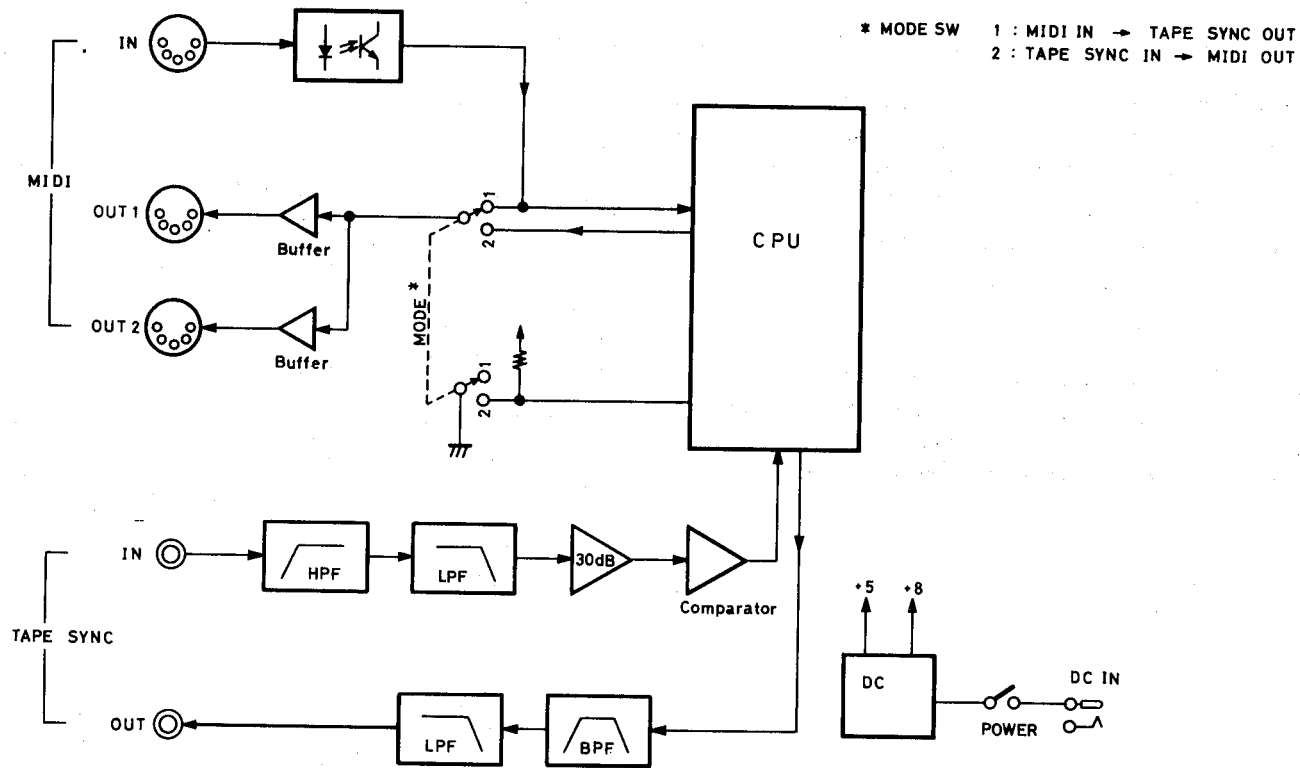

YAMAHA

YAMAHA CORPORATION
P.O.Box 1, Hamamatsu, Japan

VD69540 88 08 R2 ① Printed in Japan