

DIGITAL DRUMMER

# EMR-1

USER'S GUIDE

BEDIENUNGSANLEITUNG

MANUEL DE L'UTILISATEUR

MANUAL DE INSTRUCCIONES

Thank you for purchasing a Yamaha EMR-1 Digital Drummer. The EMR-1 is a sophisticated but easy-to-use Digital Drummer designed primarily for use with Yamaha Clavinova, PortaTone and PortaSound instruments, and which incorporates the very latest Yamaha technology. In order to obtain maximum performance, we urge you to read this User's Guide thoroughly before using your EMR-1, and keep the manual in a safe place for later reference.

## Contents

|   | Page |   | Page |
|---|------|---|------|
| 1. The Power Supply .....                       | 2    | 6. Troubleshooting .....                      | 17   |
| 2. Description of Controls and Connectors ..... | 3    | 7. MIDI System Realtime Message Information . | 17   |
| 3. System Examples .....                        | 5    | 8. MIDI System Exclusive Message Information  | 18   |
| 4. Operation .....                              | 6    | 9. Specifications .....                       | 18   |
| 5. MIDI Control .....                           | 14   |   |      |

## Precautions ... READ THIS FIRST!

To ensure safe, reliable operation of your EMR-1, please read the following precautions carefully.



### ••• Choosing a Location for your EMR-1

Avoid placing the EMR-1 in the following locations to prevent possible damage:

- Locations exposed to direct sunlight or near sources of heat.
- Excessively cold locations.
- Locations exposed to high humidity or excessive dust.
- Locations subject to vibration or shock.
- Locations next to transformers or motors (e.g. refrigerators or similar heavy equipment), fluorescent lighting fixtures, television receivers, etc. This type of equipment emits electrical noise which may cause a buzzing or humming sound from the EMR-1.



### ••• Never Apply Unnecessary Force

The EMR-1 is a precision electronic device, and can be damaged if dropped or subject to strong physical shocks. Handle it with care.



### ••• The Power Supply

Use **ONLY** the specified power supply for the EMR-1, and always turn the power switch **OFF** and disconnect the power adaptor from the AC wall outlet after use.

#### **Cautions:**

Do not place the AC power adaptor on top of the EMR-1.



### ••• External Cleaning

Clean the outer case with a soft, dry cloth. Never use solvents such as benzine or thinner, as these can damage the finish.



### ••• Connection with Other Devices

Before connecting the EMR-1 to a keyboard or other electronic device, make sure the power to both devices is turned **OFF**. Also make sure the power is **OFF** when connecting or disconnecting the optional FC-5 footswitch.

# 1 The Power Supply

The EMR-1 is designed for use with an optional Yamaha Power Adaptor. Read the following instructions carefully to ensure that you select the appropriate Power Adaptor and connect it properly.

## Using the EMR-1 Alone

If you intend to use the EMR-1 alone (without other Yamaha EM-series devices), select a Yamaha PA-1, PA-4 (PA-40 in U.S.) or PA-5 Power Adaptor. Attempting to use other power adaptors can result in serious damage to the EMR-1.

## Using the EMR-1 with Other EM-series Devices

If you plan to use the EMR-1 together with another EM-series device (such as the EMT-10 AWM Sound Expander), select the Yamaha PA-5 Power Adaptor. The PA-5 has sufficient power capacity (2 Amperes) to power two or three EM-series devices as long as their total power consumption does not exceed 2 Amperes.

Connect the power supply as shown in the diagram to the right. Use the DC cord provided to connect the DC OUT jack of the device powered by the PA-5 to the DC IN jack of the second device.

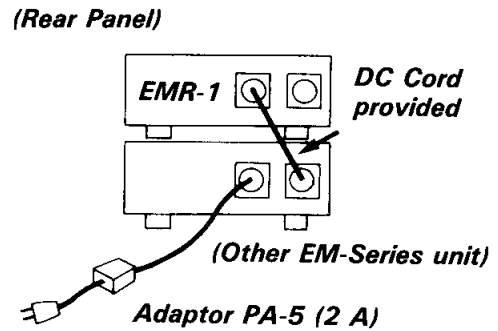

## Powering 3 or More EM-series Devices

A single PA-5 Power Adaptor can supply a maximum of 2 Amps (2000 mA), and can therefore be used to power three or more EM-series devices as long as their power consumption does not exceed this value.

### [Combination Example 1]

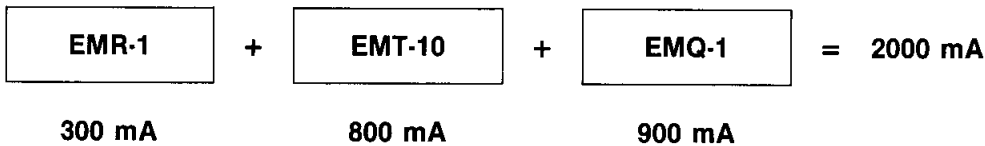

The total power consumption of the combination shown above does not exceed 2000 mA, so a single PA-5 is sufficient.

### [Combination Example 2]

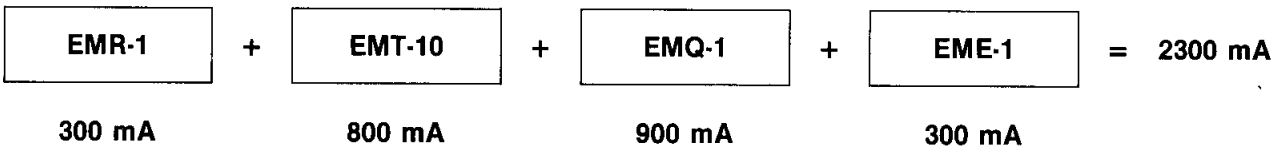

In this case the 2000 mA limit is exceeded, and two Power Adaptors will be required.

## Installing the Holders and Mounting Plates

- The EMR-1 comes supplied with two holders and two mounting plates. If you will be placing the EMR-1 on top of a Clavinova or other keyboard with top-mounted speakers, the holders and mounting plates raise the EMR-1 to prevent obstruction of the speaker.

Attach one of the mounting plates to the five grooves on one of the holders. Then attach the mounting plate to the grooves on one side of the EMR-1. For added stability screw two of the screws provided into the holes in the bottom panel via the holes in the holder.

Repeat this process with the remaining holder and mounting plate on the other side of the EMR-1.

- To mount an EM-series device on top of another, use only the mounting plates to connect the grooves of the upper and lower units.

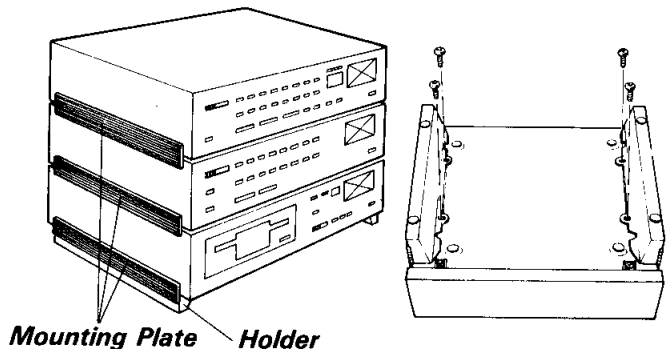

## 2 Description of the Controls and Connectors

### Front Panel

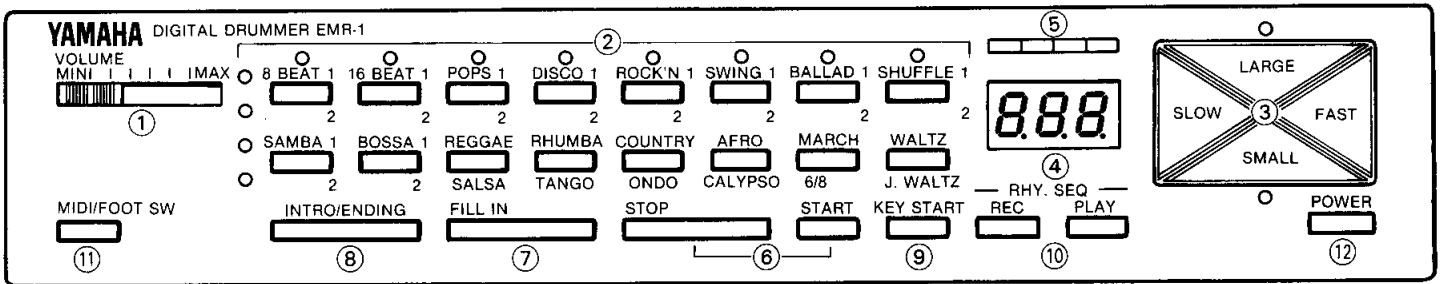

#### ① VOLUME Control

The VOLUME control adjusts the volume level of the EMR-1's rhythms delivered via the rear-panel LINE OUT jacks.

- Signals received via the rear-panel AUX IN jacks are not affected by the VOLUME control.

#### ② Voice Selectors & Indicators

The EMR-1's 32 superb rhythm patterns are selected using these 16 selector buttons. The LED indicators above and to the left of the rhythm selectors indicate the currently selected voice.

#### ③ Rhythm Variator and Indicators

The SMALL and LARGE buttons make it possible to vary the "size of the rhythm section" playing the currently selected rhythm. The FAST and SLOW buttons allow variation of the tempo of the selected rhythm (the rhythm pattern also changes to provide the best sound with the selected tempo). The LED indicators associated with the SMALL and LARGE buttons show whether the small, normal or large rhythm section is currently selected. These indicators also show the status of many of the EMR-1's other functions.

#### ④ Measure/Tempo Display

This 3-digit LED display shows the number of measures played during normal rhythm playback, the currently selected tempo when the rhythm is stopped or when the SLOW and FAST buttons are used to vary tempo, and other important information in other EMR-1 modes.

#### ⑤ Beat Display

The four-segment LED beat display above the Measure/Tempo Display shows the beats of each measure during rhythm playback. The first beat of each measure is indicated by the red LED segment to the left, while the remaining beats are indicated by the green segments to the right.

#### ⑥ START & STOP Buttons

The START and STOP buttons start and stop the selected EMR-1 rhythm.

#### ⑦ FILL IN Button

This button can be used to add rhythm variations or "fill-ins" at any point during rhythm playback.

#### ⑧ INTRO/ENDING Button

Press this button while the EMR-1 is in the "STOP" mode to start the selected rhythm with a 2-measure intro, or during rhythm playback to end with a rhythmic ending rather than simply stopping the rhythm.

#### ⑨ KEY START Button

The KEY START button places the EMR-1 in the KEY START mode, allowing rhythm playback to be initiated by playing a note on a MIDI keyboard connected to the EMR-1's MIDI IN connector.

#### ⑩ Rhythm Sequencer Buttons (REC and PLAY)

The REC and PLAY buttons are used to record and playback a sequence of rhythms and rhythm variations. Tempo variations can also be recorded and played back.

#### ⑪ MIDI/FOOT SW Button

The MIDI/FOOT SW button provides access to a number of MIDI control and footswitch functions that add significantly to the versatility of the EMR-1.

#### ⑫ POWER Switch

Press once to turn power ON, a second time to turn power OFF. The 8 BEAT 1 rhythm will be selected when the power is initially turned ON.

## ■ Rear Panel

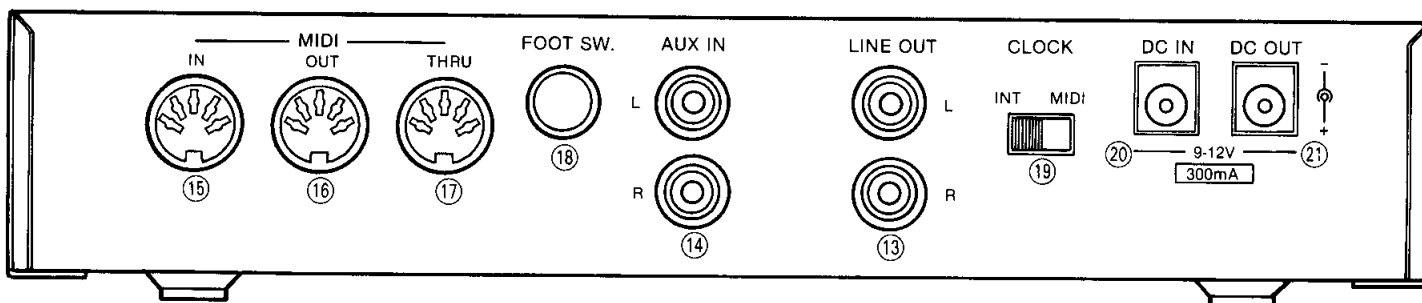

### ⑬ LINE OUT Jacks

These are the main outputs from the EMR-1. They should normally be connected to the inputs of your amplifier/speaker system or instrument.

### ⑭ AUX IN Jacks

A second instrument or line-level source can be connected to these jacks. Signals received at the AUX IN jacks are mixed with the EMR-1 rhythms and output via the LINE OUT jacks, but the front-panel VOLUME control setting does not affect the AUX IN signals.

### ⑮ MIDI IN Connector

MIDI data from a keyboard's MIDI OUT connector or other MIDI device is received via this connector. The received MIDI data "tells" the EMR-1 how to respond to actions performed on the keyboard or other MIDI device.

### ⑯ MIDI OUT Connector

MIDI data generated by the EMR-1 itself is transmitted via this connector. If the MIDI OUT connector is connected to a keyboard's MIDI IN connector, for example, it is possible to select voices on the keyboard from the EMR-1's rhythm selectors.

### ⑰ MIDI THRU Connector

The MIDI THRU connector simply re-transmits any data received via the MIDI IN connector, allowing several MIDI devices like the EMR-1 to be "chained" together and controlled simultaneously.

### ⑱ FOOT SW Jack

An optional Yamaha FC-5 Footswitch connected to this jack can be used for convenient foot control of a number of EMR-1 functions.

### ⑲ INT/MIDI CLOCK Switch

Normally this switch must be set to the INT position, causing the EMR-1 to be controlled by its own internal clock. If the CLOCK switch is set to the MIDI position, the timing of the EMR-1 rhythms can only be controlled by MIDI clock data received at the MIDI IN connector from an external device such as a MIDI sequencer or Disk Recorder (Yamaha EMQ-1, for example).

### ⑳ DC IN Jack

The optional Yamaha PA-1/PA-4/PA-40/PA-5 Power Adaptor connects to this jack.

### ㉑ DC OUT Jack

Supplies power to another EM-series device via the supplied DC cord.

# 3 System Examples

The systems shown below represent only a few of the possibilities available with the EMR-1. With these examples, however, you should be able to apply the EMR-1 in just about any type of system. Of course, the EMR-1 doesn't necessarily have to be used in a keyboard system. It will function perfectly well as an independent rhythm machine for use with guitars and other instruments.

**Note:**

Certain EMR-1 functions—such as KEY START which allows rhythms to be started from your keyboard—require the keyboard you use to have a MIDI OUT connector.

### 1. Keyboard with Internal Speakers + EMR-1

This type of system is the most simple and convenient since it allows you to play along with rhythms produced by the EMR-1 without the need for an external amplifier/speaker system.

The MIDI OUT connector of the keyboard should be connected to the EMR-1 MIDI IN connector using the MIDI cable provided (the MIDI cable has a 5-pin connector on either end). If your keyboard has stereo LINE IN, AUX IN or OPTIONAL IN jacks, the EMR-1's LINE OUT jacks should be connected to these using the connecting cord provided. If your keyboard only has a single (mono) LINE IN or AUX IN jack, connect it to the EMR-1's LINE OUT L jack.

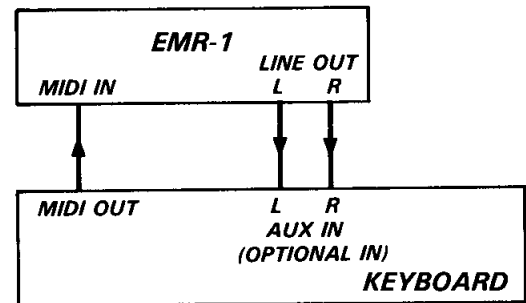

### 2. Keyboard + EMR-1 + External Sound System

This type of setup can be used with virtually any keyboard instrument, and provides the advantage of bigger, more dynamic sound thanks to external amplification.

The MIDI connections are made in the same way as described in system 1, above. The EMR-1 LINE OUT jacks are connected directly to an external amplification system and, if you want to send the keyboard sound to the external sound system as well, the keyboard LINE OUT jacks can be connected to the EMR-1 AUX IN jacks.

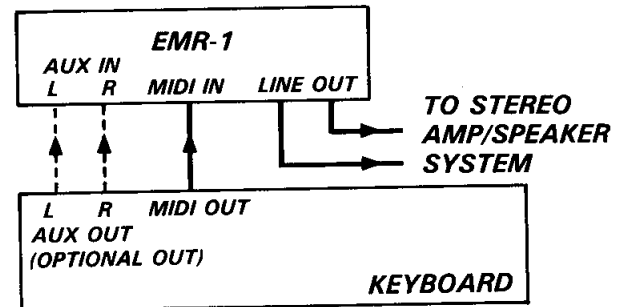

### 3. Keyboard with Internal Speakers + EMR-1 + EMT-1 or EMT-10

In this system, the EMR-1 is used together with an EMT-1 FM Sound Expander or EMT-10 AWM Sound Expander to add a range of outstanding voices to your keyboard as well as providing life-like rhythms.

Since the EMT-1 and EMT-10 require MIDI control from the keyboard, the unit used should be connected into the MIDI control chain as described below (refer to the EMT-1 or EMT-10 User's Guide for details).

The MIDI connections between the keyboard and EMR-1 are made as described in the previous systems. The MIDI THRU connector of the EMR-1 is then connected to the MIDI IN connector of the EMT-1 or EMT-10 so that MIDI signals transmitted by the keyboard are received by both the EMR-1 and EMT-1/EMT-10. The LINE OUT jacks of the EMT-1/EMT-10 are connected to the AUX IN jacks of the EMR-1, and the LINE OUT jacks of the EMR-1 are connected to the LINE IN, AUX IN or OPTIONAL IN jacks on the keyboard.

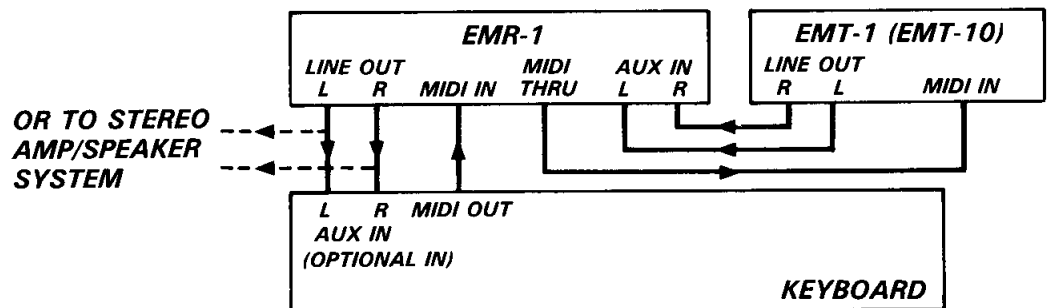

**Note:** If your keyboard does not have LINE IN, AUX IN or OPTIONAL IN jacks, the LINE OUT jacks of the EMR-1 can be fed to an external amplifier/speaker system.

# 4 Operation

## Preliminary Notes

The EMR-1 permits some functions to be controlled by MIDI data from a keyboard or other MIDI device. If MIDI control is to be used, the EMR-1's MIDI receive and send channel numbers must be set to the same channel numbers on which the controlling keyboard is sending and receiving for proper operation. When the EMR-1 is initially turned ON, it is automatically set to the OMNI receive mode allowing reception on all MIDI channels. The send channel is automatically set to channel 1. This means that if you don't have any specific MIDI-related requirements you can simply turn ON and use the MIDI control functions.

If your system includes several devices that will be operating on different MIDI channels, you may need to set the EMR-1 MIDI channels accordingly. Refer to the "Setting the MIDI Send and Receive Channels" and "Setting the MIDI Mode" sections on page 14 of this User's Guide for details.

When properly set up, the EMR-1 KEY START function allows the selected rhythm to be started automatically as soon as a key is played on your keyboard, and the EMR-1's individual percussion "instruments" can be played directly from the keyboard (See "The Keyboard Percussion Mode" on page 13).

## The Volume Control

Begin by setting the VOLUME control to a position about three-quarters of the way toward the "MAX" end of the scale. Then, when you actually begin playing the EMR-1, you can set the best VOLUME control level "by ear."



## Selecting Rhythm Patterns

The EMR-1's 32 rhythm patterns are selected using 16 rhythm selectors. Note that each rhythm selector has a label above and below it. The rhythm patterns indicated by the upper and lower labels are selected alternately each time the corresponding selector is pressed. For example, if the DISCO 1 rhythm is selected and you press the same selector a second time, the DISCO 2 rhythm will be selected. Each press on the DISCO 1/DISCO 2 selector alternately selects the DISCO 1 and DISCO 2 rhythm patterns.

The two LEDs to the left of each row of rhythm selectors indicate whether an upper or lower rhythm is selected. The LEDs above the selectors indicate which selector is currently active.

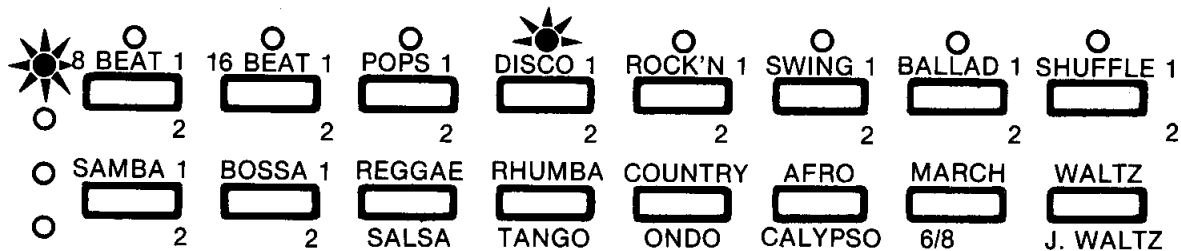

In this example the indicator LEDs show that the DISCO 1 rhythm is selected.

- The 8 BEAT 1 rhythm is automatically selected when the power is initially turned ON.

## ■ Selecting Rhythms from Your Keyboard or Other MIDI Device

Many MIDI keyboards send MIDI program change numbers when one of their voice selectors is pressed. This capability allows EMR-1 rhythms to be selected directly from the controlling keyboard by simply pressing the appropriate voice selector on the keyboard. The following chart shows which EMR-1 rhythms are selected according to received MIDI program change numbers.

| VOICE     | VOICE SELECTOR<br>(PROGRAM CHANGE NO.) | VOICE     | VOICE SELECTOR<br>(PROGRAM CHANGE NO.) | VOICE     | VOICE SELECTOR<br>(PROGRAM CHANGE NO.) |
|-----------|--|-----------|--|-----------|--|
| 8 BEAT 1  | 0                                      | RHUMBA    | 11                                     | BALLAD 2  | 22                                     |
| 16 BEAT 1 | 1                                      | COUNTRY   | 12                                     | SHUFFLE 2 | 23                                     |
| POPS 1    | 2                                      | AFRO      | 13                                     | SAMBA 2   | 24                                     |
| DISCO 1   | 3                                      | MARCH     | 14                                     | BOSSA 2   | 25                                     |
| ROCK'N 1  | 4                                      | WALTZ     | 15                                     | SALSA     | 26                                     |
| SWING 1   | 5                                      | 8 BEAT 2  | 16                                     | TANGO     | 27                                     |
| BALLAD 1  | 6                                      | 16 BEAT 2 | 17                                     | ONDO      | 28                                     |
| SHUFFLE 1 | 7                                      | POPS 2    | 18                                     | CALYPSO   | 29                                     |
| SAMBA 1   | 8                                      | DISCO 2   | 19                                     | 6/8       | 30                                     |
| BOSSA 1   | 9                                      | ROCK'N 2  | 20                                     | J.WALTZ   | 31                                     |
| REGGAE    | 10                                     | SWING 2   | 21                                     |           |  |

The EMR-1 also sends the above program change numbers whenever a rhythm is selected using the front-panel rhythm selectors. If your keyboard is set up to receive program change numbers, keyboard voices can also be selected using the EMR-1 rhythm selectors. To do this, the MIDI OUT connector of the EMR-1 must be connected to the MIDI IN connector of your keyboard.

- Reception and transmission of MIDI program change numbers can be turned OFF if desired. See "Program Change ON/OFF" on page 15 of this user's guide.
- If your keyboard only has, for example, 5 voices and thus 5 voice selectors, only the first 5 EMR-1 rhythms can be selected from the keyboard.

## Starting and Stopping the Selected Rhythm

### ■ Using the START and STOP Buttons

The most straightforward way to start and stop the selected EMR-1 rhythm is to use the START and STOP buttons. Simply press the START button to start the rhythm, then press the STOP button when you want to stop the rhythm.



**Note:** Make sure that the rear-panel CLOCK switch is set to INT.

- Different rhythms can be selected at any time during playback.
- The currently selected tempo is displayed on the Measure/Tempo Display while rhythm playback is stopped.
- The total number of measures played (i.e. the number of the current measure) will be shown on the LED Measure/Tempo Display during rhythm playback.

### ■ Using the INTRO/ENDING Button

This button can be used to both start and stop the selected rhythm, with a little more "style" than the START and STOP buttons provide. If you press the INTRO/ENDING button while rhythm playback is stopped, the selected rhythm will start after an appropriate 2-measure introduction. When you're ready to end the rhythm, press the INTRO/ENDING button again—the EMR-1 will create an appropriate 2-measure rhythmic ending for the currently selected rhythm pattern.

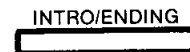

- If you press the INTRO/ENDING button during the first half of a measure, the ending pattern will begin during that measure. If you press the INTRO/ENDING button during the second half of a measure, the ending pattern will begin on the first beat of the next measure.
- Rhythm playback started by pressing the START button can be ended by pressing the INTRO/ENDING button. In the same way, rhythm playback started by pressing the INTRO/ENDING button can be ended at any time by pressing the STOP button.



## Adding Fill-Ins

Simply press the FILL IN button at any time during rhythm playback to insert an exciting rhythm variation that lasts until the end of the current measure. The fill-in can be terminated at any time during the same measure by pressing the FILL IN button a second time. For example, if you press FILL IN on the first beat of a measure and then again on the third beat, the fill-in will last from the first until the third beat of the measure.

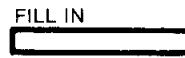

### ■ Fill-in Start

You can start a rhythm pattern with a fill-in on the very first measure by first pressing the FILL IN button while rhythm playback is stopped, and then pressing the START button. When the FILL IN button is initially pressed (while rhythm playback is stopped), the third (green) LED segment on the Beat Display will light, indicating that the first measure of the rhythm pattern will be a fill-in.



## Modifying the Rhythm Section Size & Tempo

### ■ LARGE/SMALL (Rhythm section size) Variation

The large SMALL and LARGE buttons located to the right of the panel can be used to modify the “size” of the rhythm section played by the EMR-1.

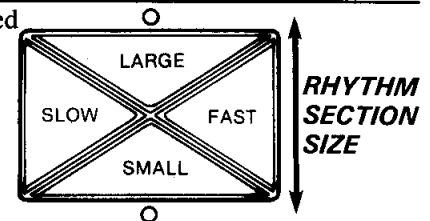

When neither the SMALL or LARGE LEDs are lit, which is the case immediately after the POWER switch has been turned ON, the rhythm section size is set to NORMAL. Pressing the LARGE button once causes the LARGE LED to light and sets the LARGE rhythm section configuration—you’ll hear more instruments and a more complex rhythm. From the LARGE setting, pressing the SMALL button once restores the normal rhythm section size, and pressing the SMALL button a second time sets the SMALL rhythm section size (the SMALL LED will light and you’ll hear fewer instruments).

### ■ SLOW/FAST (Tempo) Variation

The large SLOW and FAST buttons located to the right of the panel can be used to modify the tempo of the selected rhythm. Tempo can be varied from 32 beats per minute up to 280 beats per minute.

When the EMR-1 is initially turned ON a tempo of 120 is automatically selected.

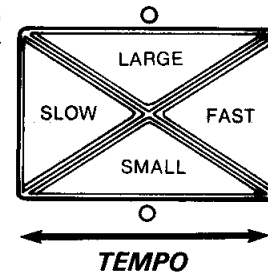

Pressing the SLOW button decreases the tempo, while pressing the FAST button increases the tempo. Holding either of these buttons down causes a continuous increase or decrease in the tempo setting. The current tempo setting is displayed on the Measure/Tempo Display while either the SLOW or FAST button is pressed during rhythm playback, and the display reverts to measure number display about one second after either the SLOW or FAST button is released. The tempo setting is also displayed, and can be changed, while rhythm playback is stopped.

**Note:** If the rear-panel CLOCK switch is set to MIDI and the EMR-1 is being controlled by an external clock signal, the front-panel SLOW and FAST buttons will have no effect.

Each of the EMR-1’s rhythms has an “optimum” tempo setting which is automatically recalled when a rhythm is selected. If the tempo setting has been changed by operating the SLOW and FAST buttons, the initial tempo setting can be automatically recalled by pressing both the SLOW and FAST buttons simultaneously while the rhythm is selected. This works both while rhythm playback is stopped or while the rhythm is playing.

- As you change the tempo of a rhythm, the rhythm pattern changes slightly to provide the best overall sound within the current tempo range.

## The KEY START Function

This function causes the selected rhythm to be started automatically when you play the first note on your keyboard, thus synchronizing the beginning of the rhythm to your performance.



**Note:** This function requires MIDI control from your keyboard. The MIDI OUT connector of your keyboard must therefore be connected to the MIDI IN connector of the EMR-1.

After selecting the desired rhythm, press the KEY START button. The first (red) LED segment of the Beat Display will begin to flash, indicating that the EMR-1 is in the KEY START mode. Then, as soon as you play a key on your keyboard, playback of the selected rhythm will begin.



You can have the rhythm begin with a fill-in in the KEY START mode by pressing the KEY START and FILL IN buttons simultaneously before playing your keyboard. In this case, both the first (red) and third (green) LED segments of the Beat Display will flash while the EMR-1 waits for you to play on the keyboard.



### ■ Key Split KEY START Operation

This function makes it possible to define a range of notes on the left-hand side of your keyboard which can be used for KEY START. If you press the RHUMBA rhythm selector while holding the MIDI/FOOT SW button, and then (still holding the MIDI/FOOT SW button) press a key on your keyboard, the KEY START function will only be activated (i.e. the rhythm will only start playing) when a key to the left of that key is pressed. If you simply press RHUMBA while holding MIDI/FOOT SW and do not press a key on your keyboard, the F#2 key is selected by default.

## Footswitch Functions

An optional Yamaha FC-5 Footswitch plugged into the rear-panel FOOT SW can be set to perform the following functions:

FOOT SW.



**Caution:** Always make sure that the EMR-1 power is OFF when connecting or disconnecting the optional FC-5 footswitch.

### ■ INTRO/ENDING

While holding the MIDI/FOOT SW button, press the INTRO/ENDING button. This sets the footswitch to perform the same function as the front-panel INTRO/ENDING button.

Press the footswitch to start the selected rhythm with an introduction. Press the footswitch a second time to stop the rhythm with an appropriate ending.

### ■ FILL IN

While holding the MIDI/FOOT SW button, press the FILL IN button.

This sets the footswitch to perform the same function as the front-panel FILL IN button.

Press the footswitch at any time during rhythm playback to add a fill-in.

### ■ START

While holding the MIDI/FOOT SW button, press the START button. This sets the footswitch to perform the same function as the front-panel START button.

Press the footswitch to start the selected rhythm. In this case the footswitch cannot be used to stop the rhythm.

### ■ START/STOP

This is the default footswitch function, and does not have to be specifically set if you have simply plugged in a footswitch and turned the EMR-1 ON. If you have selected a different footswitch function, however, the START/STOP function can be reset as follows.

While holding the MIDI/FOOT SW button, press the STOP button.

This sets the footswitch to perform the same functions as the front-panel START and STOP buttons.

Press the footswitch once to start the selected rhythm, and a second time to stop the rhythm.

## ■ BREAK

“BREAK” is a function that can only be activated using the optional FC-5 footswitch—no front-panel BREAK control is provided.

While holding the MIDI/FOOT SW button, press the KEY START button. This sets the footswitch to function as a BREAK footswitch, stopping and starting the rhythm sound while maintaining the tempo and rhythmic timing.

Press the footswitch whenever you want to insert a break in the rhythm—the rhythm sound stops but the tempo and rhythm timing are maintained and, if the footswitch is released immediately, the rhythm resumes from the first beat of the following measure. If the footswitch is pressed a second time during the same measure, the rhythm resumes immediately. If the footswitch is held, the break will continue until it is released and the rhythm will start again from the beginning of the following measure.

## ■ Break Start

When the footswitch is set for BREAK operation, it can also be used to activate a “BREAK START” function. If the footswitch is pressed before the rhythm is started, the fourth (green) LED segment on the BEAT display will light indicating that the EMR-1 is in the BREAK START mode. Then when the rhythm is started by pressing the START button or by using the KEY START function, the first measure will be silent. The rhythm sound will actually begin from the second measure.

## Using the Rhythm Sequencer

The EMR-1's Rhythm Sequencer functions allows you to record a sequence of rhythm patterns with intros, fill-ins, tempo variations, rhythm section size variations and endings, making it possible to create complex rhythm backings for your performances and compositions.

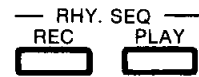

To describe the operation of the Rhythm Sequencer, we'll use an actual example—a 10-measure recording in which:

- The first two measures are a POPS 1 rhythm INTRO at a tempo of 94.
- The third measure is a standard POPS 1 rhythm.
- The fourth measure is a POPS 1 rhythm FILL IN.
- The fifth and sixth measures are a POPS 1 rhythm with the LARGE rhythm section size at a tempo of 120.
- The seventh and eighth measures are a standard SAMBA 1 rhythm.
- The ninth and tenth measures are a SAMBA 1 ENDING.

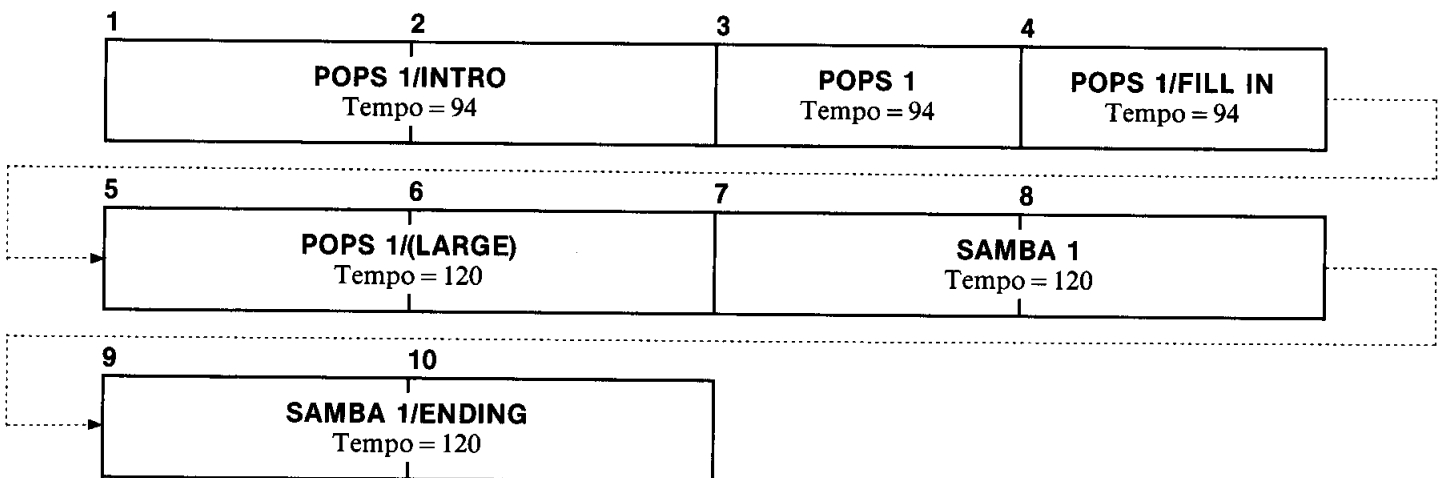

### The Measure/Tempo Display Dots

The LED dots following each of the three digits in the Measure/Tempo display have the following meanings when the EMR-1 Rhythm Sequencer functions are in use.

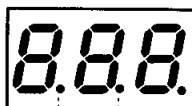

..... Lights during sequence playback.

..... Lights during the sequence check mode.

..... Lights during sequence recording.

## ■ Recording the Rhythm Sequence

1. Press the PLAY button while holding the REC button to enter the RECORD mode. "CLr" will appear on the Measure/Tempo display for about a second, indicating that any previous recording has been "cleared." The display then switches to ". 0" indicating that the EMR-1 is ready to record the first measure.

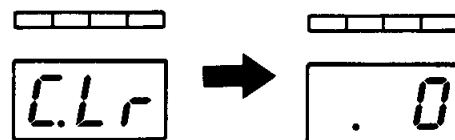

2. Select the desired rhythm—in this case POPS 1. Press the SLOW and FAST buttons simultaneously to set the optimum tempo (94) for the selected rhythm (POPS 1). Press the INTRO/ENDING button (the second (green) Beat Display segment will light).

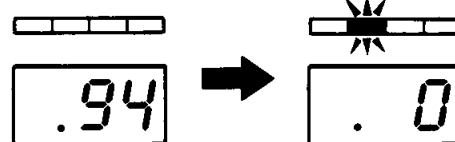

3. Now, when you press the REC button all the settings you made in step 2, above, will actually be recorded. The Measure/Tempo display will show "2" to indicate that 2 measures have been recorded (you just recorded a POPS 1 INTRO, which is 2 measures long). The second (green) segment in the Beat Display will go out indicating that INTRO/ENDING is no longer selected.

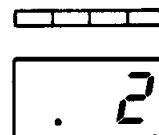

4. Press the REC button once again to record one measure of the standard POPS 1 rhythm. "1" will be shown on the Measure/Tempo display, indicating that one measure has been recorded since the last data change (in this case, the end of the INTRO). After about a second, the display will then show the total number of measures recorded—"3" at this point.

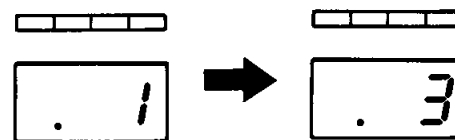

5. Press the FILL IN button. The third (green) segment of the Beat Display will light indicating that you are ready to record a FILL IN.

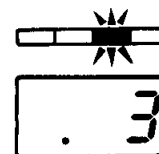

6. Press the REC button to record the POPS 1 FILL IN. As you do this the Measure/Tempo display will show "1" indicating that one measure has been recorded since the last data change (FILL IN selected), then after about a second it will display "4"—the total number of measures recorded. Note also that now that the FILL IN has been recorded, the third (green) Beat Display LED has gone out.

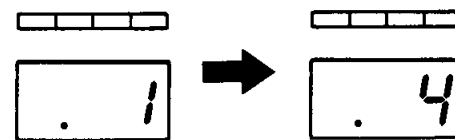

7. Press the LARGE button to select the LARGE rhythm section for POPS 1, then press the FAST button until a tempo setting of 120 is achieved.

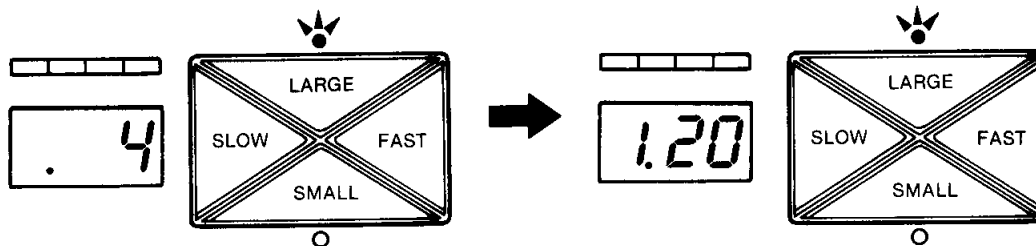

8. Press the REC button twice to record two measures of LARGE rhythm section POPS 1 rhythm at a tempo of 120. The total number of measure recorded is now 6.

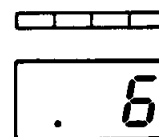

9. Press the SAMBA 1 rhythm selector. Press the SMALL button to restore the rhythm section size to normal.

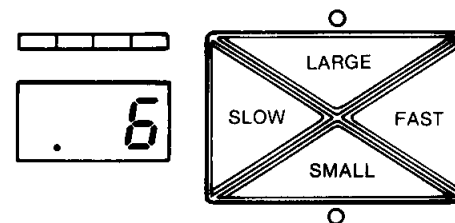

10. Press the REC button twice to record two measures of the standard SAMBA 1 rhythm.



11. Press the INTRO/ENDING button (the second (green) Beat Display segment will light).



12. Press the REC button to record the SAMBA 1 rhythm ENDING (2 measures for a total of 10).

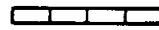

13. Press the STOP button to finish the recording. "End" will appear on the Measure/Tempo display for about a second, then normal EMR-1 operation will be resumed.



### General Recording Procedure Summary

1. Press the PLAY button while holding the REC button to enter the record mode.
2. Set the desired data.
  - INTRO/ENDING is indicated by the 2nd (green) Beat LED.
  - FILL IN is indicated by the 3rd (green) Beat LED.
  - BREAK (foot switch) is indicated by the 4th (green) Beat LED.
3. Record the current data by pressing the REC button.
  - The number of measures recorded since the last data change is first displayed, followed by the total number of measures recorded.
  - It is possible to return to the previous measure by pressing the REC button while holding the MIDI/FOOT SW button.
4. Finish by pressing the STOP button.

### ■ Playing Back the Recorded Rhythm Sequence

To play back the rhythm sequence, first press the PLAY button.

"PLy" will flash on the Measure/Tempo display indicating that the EMR-1 is ready to begin playback of the recorded sequence. Press the START button to actually begin sequence playback. You can also press the INTRO/ENDING button before pressing START to start the sequence with an introduction. The sequence will play through to the end, at which point "End" will appear on the Measure/Tempo display for about one second, then the EMR-1 will return to the normal mode.

- During sequence playback the START button can be used to "pause" playback. Press START once to temporarily stop the rhythm, and again to start the rhythm from the same point.
- Sequence playback can be stopped at any time by pressing the STOP button, or a footswitch set up for STOP/START operation.

### ■ Checking the Recorded Sequence

The Recorded sequence can be checked step-by-step by pressing the PLAY button while holding the MIDI FOOT SW button. Each time you press the PLAY button while holding the MIDI/FOOT SW button the number of measures for which the same data continues is shown on the Measure/Tempo display, the data itself is shown by the various indicators (i.e. the selected rhythm, LARGE/SMALL settings, INTRO/ENDING, etc), and finally the current measure number is displayed. When the end of the sequence is reached, "End" is shown on the Measure/Tempo display, immediately followed by the total number of measures in the sequence.

Exit from the CHECK mode by pressing the STOP button.

### ■ Editing the Recorded Sequence

If the REC and PLAY buttons are pressed simultaneously while in the CHECK mode described above, the record mode is entered from the measure following the currently displayed measure number. Recording can then be carried out from the current measure number in the normal way. If you need to change a portion of a recorded sequence, therefore, you can do it by re-recording from the measure which has to be changed rather than having to re-record the entire sequence from the very beginning.

- If the REC and PLAY buttons are pressed simultaneously to enter the record mode as described above, all data after the point at which the record mode is entered is immediately erased. Use caution when activating this function.

## The Keyboard Percussion Mode

In the Keyboard Percussion mode, the EMR-1's various instruments can be played directly from your keyboard. You can play your own rhythm pattern, or add rhythmic accents during rhythm playback.

**Note:** This function requires MIDI control from your keyboard. The MIDI OUT connector of your keyboard must therefore be connected to the MIDI IN connector of the EMR-1. The MIDI OMNI mode of the EMR-1 must be ON, or the receive channel must be matched to the send channel of your keyboard. Refer to "5. MIDI Control" on page 14.

Each instrument has its own "instrument Number," and is assigned to a specific key on your keyboard (i.e. a specific MIDI note number). The available instruments, their instrument numbers and default note assignments are given in the chart below.

| INST. NO. | INSTRUMENT                  | DEFAULT NOTE. (MIDI NOTE NO.) | INST. NO. | INSTRUMENT                    | DEFAULT NOTE. (MIDI NOTE NO.) |
|-----------|-----------------------------|-------------------------------|-----------|-------------------------------|-------------------------------|
| 1         | HH CLOSED (HI-HAT CLOSED)   | C# <sub>2</sub> (49)          | 21        | TIMBALE LO (TIMBALE LOW)      | F <sub>3</sub> (65)           |
| 2         | HH OPEN (HI-HAT OPEN)       | D# <sub>2</sub> (51)          | 22        | CUICA HI (CUICA HIGH)         | B <sub>3</sub> (71)           |
| 3         | CRASH CYMBAL                | G# <sub>2</sub> (56)          | 23        | CUICA LO (CUICA LOW)          | A <sub>3</sub> (69)           |
| 4         | SNARE DRUM HEAVY            | G <sub>1</sub> (43)           | 24        | AGOGO HI (AGOGO HIGH)         | D# <sub>4</sub> (75)          |
| 5         | BASS DRUM                   | F <sub>1</sub> (41)           | 25        | AGOGO LO (AGOGO LOW)          | C# <sub>4</sub> (73)          |
| 6         | HH PEDAL (HI-HAT PEDAL)     | A# <sub>1</sub> (46)          | 26        | COWBELL                       | A# <sub>3</sub> (70)          |
| 7         | RIDE CYMBAL                 | F# <sub>2</sub> (54)          | 27        | BONGO                         | E <sub>3</sub> (64)           |
| 8         | SNARE DRUM LIGHT            | A <sub>1</sub> (45)           | 28        | TAMBOURINE                    | F# <sub>4</sub> (78)          |
| 9         | SNARE DRUM ECHO             | B <sub>1</sub> (47)           | 29        | TRIANGLE CL (TRIANGLE CLOSED) | G# <sub>4</sub> (80)          |
| 10        | BRUSH                       | G# <sub>1</sub> (44)          | 30        | TRIANGLE OP (TRIANGLE OPEN)   | A# <sub>4</sub> (82)          |
| 11        | RIM                         | F# <sub>1</sub> (42)          | 31        | HAND CLAPS                    | C <sub>4</sub> (72)           |
| 12        | TOM 1                       | F <sub>2</sub> (53)           | 32        | CASTANETS                     | G# <sub>3</sub> (68)          |
| 13        | TOM 2                       | E <sub>2</sub> (52)           | 33        | WOODBLOCK HI (WOODBLOCK HIGH) | F# <sub>3</sub> (66)          |
| 14        | TOM 3                       | D <sub>2</sub> (50)           | 34        | WOODBLOCK LO (WOODBLOCK LOW)  | D# <sub>3</sub> (63)          |
| 15        | E. TOM 1 (ELECTRONIC TOM 1) | B <sub>2</sub> (59)           | 35        | SHAKER                        | C# <sub>3</sub> (61)          |
| 16        | E. TOM 2 (ELECTRONIC TOM 2) | A <sub>2</sub> (57)           | 36        | TOM 4                         | C <sub>2</sub> (48)           |
| 17        | E. TOM 3 (ELECTRONIC TOM 3) | G <sub>2</sub> (55)           | 37        | REVERSED CYMBAL               | A# <sub>2</sub> (58)          |
| 18        | CONGA HI (CONGA HIGH)       | D <sub>3</sub> (62)           |           |                               |                               |
| 19        | CONGA LO (CONGA LOW)        | C <sub>3</sub> (60)           |           |                               |                               |
| 20        | TIMBALE HI (TIMBALE HIGH)   | G <sub>3</sub> (67)           |           |                               |                               |

To enter the Keyboard Percussion mode, press the COUNTRY rhythm selector while holding the MIDI/FOOT SW button. To exit the Keyboard Percussion mode, press the COUNTRY rhythm selector while holding the MIDI/FOOT SW button again. When the Keyboard Percussion mode is ON, you can play the various instruments by playing the appropriate notes on your keyboard (refer to the chart above). When keyboard percussion is turned ON the LARGE LED will light, and when keyboard percussion is turned OFF the SMALL LED will light.

- A handy note assignment sticker is provided as an accessory with the EMR-1 (a printed version is also provided on the last page of this User's Guide). Place it anywhere you like—on the top panel of the EMR-1 is convenient—for easy reference.

### ■ To Change the Note Assignments

If you want to change the notes to which the EMR-1's instruments are assigned, do the following:

1. Press the MARCH rhythm selector while holding the MIDI/FOOT SW button. Each time you press the MARCH selector while holding the MIDI/FOOT SW button the instrument number shown on the EMR-1 display will increase by 1, and by pressing the AFRO selector while holding the MIDI/FOOT SW button the instrument number will decrease by one. Press the MARCH and/or AFRO selector until the number of the instrument you wish to assign to a new note appears on the display.
2. When the desired instrument number has been selected, press the key on your keyboard (while still holding the MIDI/FOOT SW button) to which you wish to assign the selected instrument.

### ■ Cancelling Instruments During Rhythm Playback

Specific instruments can be cancelled (they will not sound) during rhythm playback by holding down the START button and pressing the key on your keyboard to which the desired instrument is assigned. Normal operation is resumed as soon as a different rhythm is selected.

# 5 MIDI Control

## Power-on MIDI Settings

When the EMR-1 is initially turned ON, the MIDI channels and modes are automatically set as follows:

|                     |                   |
|---------------------|-------------------|
| Receive Channel     | Channel 1         |
| Send Channel        | Channel 1         |
| OMNI Mode           | ON (Receive only) |
| Program Change      | ON                |
| Keyboard Percussion | OFF               |

If the MIDI/FOOT SW button is held while the power switch is turned ON, the MIDI channels are set to match Yamaha EM-series expander modules:

|                     |            |
|---------------------|------------|
| Receive Channel     | Channel 15 |
| Send Channel        | Channel 15 |
| OMNI Mode           | OFF        |
| Keyboard Percussion | ON         |

## Setting the MIDI Send and Receive Channels

If you need to set the EMR-1 MIDI send and receive channels to any other channel than channel 1, follow the instructions given below.

1. While holding the MIDI/FOOT SW button, press the 8 BEAT rhythm selector once to set the send channel, or the 16 BEAT rhythm selector once to set the receive channel. This will cause the currently set MIDI send or receive channel to be shown on the Measure/Tempo display.

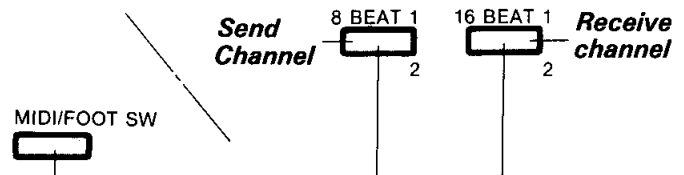

*Press while holding down the MIDI/FOOT SW button.*

2. To change the MIDI channel, press the 8 BEAT (for transmit channel) or 16 BEAT (for receive channel) rhythm selector again (while still holding the MIDI/FOOT SW button). Each time you press the 8 BEAT or 16 BEAT rhythm selector, the MIDI channel will be incremented (increased) by one, and the result shown on the Measure/Tempo display. If the rhythm selector is pressed again after the highest available MIDI channel number is reached (channel 16), channel 1 will be selected.
3. Release the MIDI/FOOT SW button when the desired MIDI channel has been set.

### ■ Automatic Receive Channel Setting

Here's a quick, easy way to match the EMR-1 MIDI receive channel to that of the controlling keyboard.

1. While holding the MIDI/FOOT SW button, press and hold the 16 BEAT rhythm selector. Then, while still holding the MIDI/FOOT SW button, press any key on the controlling keyboard. This automatically sets the EMR-1 MIDI receive channel to the keyboard's transmit channel.
2. Release the MIDI/FOOT SW button.

## Setting the MIDI Mode

In addition to MIDI send and receive channel selection, the EMR-1 makes it possible to set three other MIDI modes:

### ■ OMNI ON/OFF

When the OMNI mode is ON, the EMR-1 will receive on all MIDI channels regardless of the MIDI receive channel currently selected. When the OMNI mode is OFF, the EMR-1 will receive only on the currently selected MIDI channel. The OMNI mode is automatically turned ON whenever the EMR-1 POWER switch is turned ON.

1. While holding the MIDI/FOOT SW button down, press the POPS rhythm selector once. This will display the current OMNI status:
  - If the SMALL LED is lit, the OMNI mode is ON.
  - If the LARGE LED is lit, the OMNI mode is OFF.
2. To change the current setting, press the POPS rhythm selector a second time (while still holding the MIDI/FOOT SW button). Each time you press the POPS selector the OMNI mode will alternate between ON and OFF.
3. Release the MIDI/FOOT SW button.

### ■ Program Change ON/OFF

Normally the EMR-1 will respond to MIDI program change numbers received from the controlling keyboard, causing the correspondingly numbered EMR-1 rhythm to be selected whenever a voice selector is pressed on the keyboard. The EMR-1 will normally also send a MIDI program change number whenever one of its rhythms is selected, causing the correspondingly numbered voice to be selected on the keyboard if the keyboard is set up to receive program change numbers.

This function makes it possible to cancel program change number reception and transmission so that voices and rhythms can be independently selected on the controlling keyboard and EMR-1.

1. While holding the MIDI/FOOT SW button down, press the DISCO rhythm selector once. This will display the current program change status:
  - If the SMALL LED is lit, program change is ON.
  - If the LARGE LED is lit, program change is OFF.
2. To change the current setting, press the DISCO rhythm selector a second time (while still holding the MIDI/FOOT SW button). Each time you press the DISCO selector the program change status will alternate between ON and OFF.
3. Release the MIDI/FOOT SW button.

## Volume Control Reception

The EMR-1 can be made to receive volume control data from the controlling keyboard as follows.

1. While holding the MIDI/FOOT SW button down, press the BOSSA selector once. This will display the current volume reception status:
  - If the LARGE LED is lit, volume reception is ON.
  - If the SMALL LED is lit, volume reception is OFF.
2. To change the current setting, press the BOSSA selector a second time (while still holding the MIDI/FOOT SW button). Each time you press the BOSSA selector the volume reception status will alternate between ON and OFF.
3. Release the MIDI/FOOT SW button.



## Changing the Velocity Mode

Depending on the keyboard you use, the dynamics of EMR-1 voices played in the Keyboard Percussion Mode may not properly match those of the keyboard voices. For example, if you play a mezzoforte (mf = moderately loud) note on the keyboard, the EMR-1 voice might sound too loud in relation to the keyboard voice. This situation can be easily remedied by changing the EMR-1 VELOCITY MODE.

1. While holding the MIDI/FOOT SW button down, press the WALTZ selector once. This will display the current velocity mode:
  - If the SMALL LED is lit, the velocity mode is normal (the EMR-1 produces mf volume when it receives a MIDI velocity value of 64).
  - If the LARGE LED is lit, the EMR-1 produces mf volume when it receives a MIDI velocity value of 96—i.e. you have to play the keyboard harder to produce mf volume.
2. To change the current setting, press the WALTZ voice selector a second time (while still holding the MIDI/FOOT SW button). Each time you press the WALTZ selector the velocity mode will alternate between mf = 64 and mf = 96.
3. Release the MIDI/FOOT SW button.

## Rhythm START/STOP Reception and Transmission

Normally the EMR-1 will transmit and respond to received MIDI START and STOP messages.

This function makes it possible to cancel START/STOP reception and transmission if you do not want the EMR-1 to respond to external MIDI START/STOP messages, or an external MIDI device to be affected by START/STOP messages from the EMR-1.

1. While holding the MIDI/FOOT SW button down, press the SAMBA selector once. This will display the current START/STOP status:
  - If the LARGE LED is lit, START/STOP reception/transmission is OFF.
  - If the SMALL LED is lit, START/STOP reception/transmission is ON.
2. To change the current setting, press the SAMBA selector a second time (while still holding the MIDI/FOOT SW button). Each time you press the SAMBA selector the START/STOP reception status will alternate between ON and OFF.
3. Release the MIDI/FOOT SW button.

## Transmitting the EMR-1 Settings

This function causes all the current EMR-1 settings to be transmitted via the MIDI OUT terminal. This is particularly useful if you will be recording performances on the EMQ-1 Disk Recorder which will be used to control the EMR-1 on playback. By transmitting the EMR-1 settings and recording them on the EMQ-1 prior to the actual performance data, the EMR-1 will be automatically restored to the same settings when the performance recorded on the EMQ-1 is played back. Refer to the EMQ-1 User's Guide for operational details.

1. While holding the MIDI/FOOT SW button, press the SWING rhythm selector. This causes all the current EMR-1 settings to be transmitted via the MIDI OUT terminals.
2. Release the MIDI/FOOT SW button.

## Bulk Dump Data Transmission

Two bulk-dump data transmission functions permit bulk-dump transmission of EMR-1 data to a MIDI sequencer or disk recorder.

1. Press the BALLAD rhythm selector while holding the MIDI/FOOT SW button to transmit the EMR-1's rhythm sequence data.
2. Press the SHUFFLE rhythm selector while holding the MIDI/FOOT SW button to transmit the EMR-1's instrument/keyboard note assignments.

## 6 Troubleshooting

If the EMR-1 does not seem to be functioning properly, please check the following points before assuming that the EMR-1 is faulty.

| Symptom  | Possible Cause   |
|--|--|
| No sound.  | <ul style="list-style-type: none"> <li>• EMR-1 LINE-OUT jacks not connected to amplifier or keyboard inputs. Check all connections carefully.</li> <li>• External amplifier power not on or volume turned down.</li> <li>• EMR-1 power not on or VOLUME control is turned down.</li> <li>• Is the rear-panel CLOCK switch set to the MIDI position? Make sure this switch is set to INT if you are not driving the EMR-1 from a sequencer or disk recorder.</li> </ul> |
| Keyboard Percussion do not work.   | <ul style="list-style-type: none"> <li>• The OMNI mode is OFF and the EMR-1 MIDI receive channel is not set to match the send channel of the keyboard. Check MIDI channel settings.</li> <li>• MIDI connections between keyboard and EMR-1 not properly made. Check all connections carefully.</li> </ul>  |
| The rhythm cannot be started or the tempo cannot be changed using the SLOW and FAST buttons. | <ul style="list-style-type: none"> <li>• The rear-panel CLOCK switch is set to MIDI. Check the switch and set to INT unless external MIDI clock signals are being used.</li> </ul>   |

## 7 MIDI System Realtime Message Information

MIDI SYSTEM REALTIME MESSAGES are used primarily for timing purposes. The EMR-1 receives MIDI SYSTEM REALTIME MESSAGES via the MIDI IN connector and uses them to control tempo when the rear-panel CLOCK switch is set to the "MIDI" position.

### MIDI Timing CLock = F8H

#### Transmission:

CLOCK switch set to INT: Internal clock (1/96th-beat timing).  
 CLOCK switch set to MIDI: No data is transmitted.

#### Reception (When rhythm is running):

CLOCK switch set to INT: data discarded.  
 CLOCK switch set to MIDI: received data used as timing clock.

#### Reception (When rhythm is stopped)

CLOCK switch set to INT: data discarded.  
 CLOCK switch set to MIDI: data discarded.

- Rhythm playback will stop if the external clock signal is interrupted or stopped when the CLOCK switch is set to MIDI.
- Rhythm playback will stop if the CLOCK switch is switched from INT to MIDI during internal-clock operation.
- If the START button is pressed in an attempt to start rhythm playback while the CLOCK switch is set to MIDI and external MIDI clock signals (F8H) are not being received, "Err" (Error) will appear on the LED display. The error can be corrected by either pressing the STOP button or setting the CLOCK switch to INT.

# 8 MIDI System Exclusive Message Information

If you're already very familiar with MIDI, or are using a computer to control your music hardware with computer-generated MIDI messages, the data provided in this section can help you to control the EMR-1.

## 1. EXCLUSIVE MESSAGE FORMAT

F0H, 43H, 73H, 13H, xxH, nnH, F7H

Values for xxH and nnH in the above data string are given below.

| xxH, nnH | Parameter                                    | xxH, nnH | Parameter                                       |
|----------|--|----------|---|
| 00H, xxH | Transmit channel reception.                  | 11H, 10H | Keyboard percussion OFF transmission/reception. |
| 01H, xxH | Receive channel reception.                   | 11H, 11H | Keyboard percussion ON transmission/reception.  |
| 11H, 06H | SMALL rhythm section size transmission.      | 11H, 20H | Velocity mode mf = 64 transmission/reception.   |
| 11H, 07H | NORMAL rhythm section size transmission.     | 11H, 21H | Velocity mode mf = 96 transmission/reception.   |
| 11H, 08H | LARGE rhythm section size transmission.      | 23H, 00H | Volume control disable transmission/reception.  |
| 11H, 09H | FILL IN switch ON transmission/reception.    | 23H, 01H | Volume control enable transmission/reception.   |
| 11H, 0AH | FILL IN switch OFF transmission/reception.   | 24H, 00H | START/STOP control OFF transmission/reception.  |
| 11H, 0BH | BREAK switch ON transmission/reception.      | 24H, 01H | START/STOP control ON transmission/reception.   |
| 11H, 0CH | BREAK switch OFF transmission/reception.     | 30H, ttH | Tempo data transmission/reception.              |
| 11H, 0DH | INTRO/ENDING transmission/reception.         |          |   |
| 11H, 0EH | Sequence play switch transmission/reception. |          |   |

\* Rhythm playback will stop if a START/STOP control ON or OFF message is received.

## 2. Panel Data & Name Data Request

The following messages can only be received on the MIDI basic channel, even if the OMNI mode is ON.

a) [F0H, 43H, 2xH, 7CH, F7H]

The EMR-1 panel data is transmitted when this data string is received.

b) [F0H, 43H, 2xH, 7DH, F7H]

The EMR-1 name data is transmitted when this data string is received.

# 9 Specifications

- **Rhythms:** 8 BEAT 1, 16 BEAT 1, POPS 1, DISCO 1, ROCK'N 1 (Rock'n' Roll 1), SWING 1, BALLAD 1, SHUFFLE 1, SAMBA 1, BOSSA 1 (Bossa Nova 1), REGGAE, RHUMBA, COUNTRY, AFRO, MARCH, WALTZ, 8 BEAT 2, 16 BEAT 2, POPS 2, DISCO 2, ROCK'N 2 (Rock'n Roll 2), SWING 2, BALLAD 2, SHUFFLE 2, SAMBA 2, BOSSA 2 (Bossa Nova 2), SALSA, TANGO, ONDO, CALYPSO, 6/8, J. WALTZ (Jazz Waltz)
- **Controls:** VOLUME, Rhythm Selectors, INTRO/ENDING, FILL IN, STOP, START, KEY START, REC, PLAY, SMALL/LARGE, SLOW/FAST, MIDI/FOOT SW, Power Switch
- **Displays:** 7-segment × 3-digit LED, 4-segment LED
- **Connectors:** LINE OUT (L, R), AUX IN (L, R), MIDI IN/THRU/OUT, FOOT SW, DC IN (9—12V), DC OUT (9—12V)
- **Nominal Output Level:** +4 dBm or 3V p-p max.
- **AUX IN/LINE OUT Gain:** 0 dB ± 2 dB
- **Power Supply:** Optional Yamaha PA-1 (300 mA), PA-4/PA-40 (1 A) or PA-5 (2 A) Power Adaptor
- **Power Consumption:** 300 mA max.
- **Dimensions (W × H × D):** 218 × 44 × 215 mm (8-4/7" × 1-5/7" × 8-4/9")
- **Weight:** 1.1 kg (2.4 lbs)
- **Accessories:** DC Cord × 1, MIDI cable × 1, Connecting Cord × 1, Holder × 2, Mounting Plate × 2, Key-assign sticker × 1.

\* Specifications are subject to change without notice.

| Function            | Transmitted | Recongized     | Remarks           |
|---------------------|-------------|----------------|-------------------|
| Basic Default       | : 1         | : 1            |                   |
| Channel Changed     | : 1-16      | : 1-16         |                   |
| Mode Default        | : 3         | : 1            |                   |
| Mode Messages       | : X         | : X            |                   |
| Mode Altered        | : *****     | : X            |                   |
| Note                | : X         | : 0-127/21-127 |                   |
| Number : True voice | : *****     | : X            |                   |
| Velocity Note on    | : X         | : 0 v=1-127    |                   |
| Velocity Note off   | : X         | : X            |                   |
| After Key's         | : X         | : X            |                   |
| Touch Ch's          | : X         | : X            |                   |
| Pitch Bender        | : X         | : X            |                   |
| Control 07          | : X         | : 0            | : Volume          |
| Change              |             |                |                   |
| Program             | : 0 0-31    | : 0 0-127      |                   |
| Change : True #     | : *****     | : 0-31         |                   |
| System Exclusive    | : 0         | : 0            |                   |
| System : Song Pos   | : X         | : X            |                   |
| System : Song Sel   | : X         | : X            |                   |
| Common : Tune       | : X         | : X            |                   |
| System :Clock       | : 0         | : 0            |                   |
| Real Time:Commands  | : 0         | : 0            | :start,stop,cont: |
| Aux :Local ON/OFF   | : X         | : X            |                   |
| Aux :All Notes OFF  | : X         | : 0(123-127)   |                   |
| Mes- :Active Sense  | : 0         | : 0            |                   |
| sages:Reset         | : X         | : X            |                   |
| Notes:              |             |                |                   |

**EMR-1 NOTE ASSIGNMENTS / NOTENZUWEISUNGEN FÜR KEYBOARD-PERCUSSIONFUNKTION  
AFFECTATION DES RYTHMES AUX TOUCHES DU CLAVIER / ASIGNACIÓN DE RITMOS EN LAS TECLAS DE NOTAS**

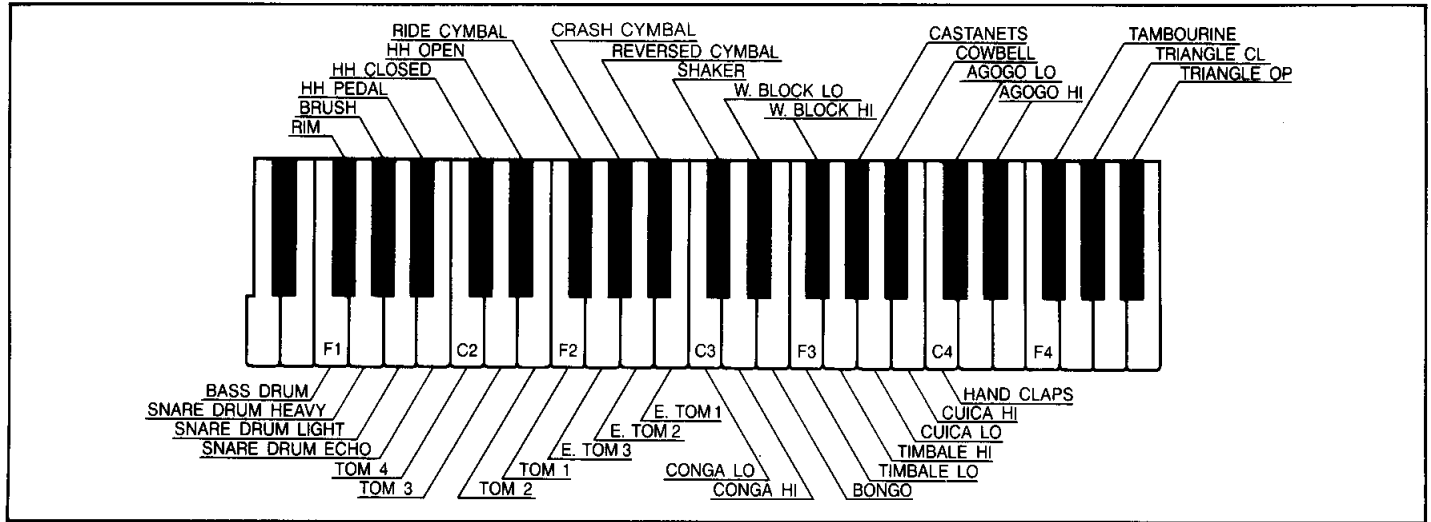

**FCC INFORMATION**

**Attention users in the U.S.A.**

This equipment generates and uses radio frequency energy and if not installed and used properly, that is, in strict accordance with the manufacturer's instructions, may cause interference to radio and television reception. It has been type tested and found to comply with the limits for a Class B computing device in accordance with the specifications in Subpart J of Part 15 of FCC Rules, which are designed to provide reasonable protection against such interference in a residential installation. However, there is no guarantee that interference will not occur in a particular installation. If this equipment does cause interference to radio or television reception which can be determined by turning the equipment off and on, the user is encouraged to try to correct the interference by one or more of the following measures.

- Reorient the receiver antenna
  - Relocate the equipment with respect to the receiver
  - Move the equipment away from the receiver
  - Plug the equipment into a different outlet so that equipment and receiver are on different branch circuits.
- If necessary, the user should consult the dealer or an experienced radio/television technician for additional suggestions. The user may find the following booklet prepared by the Federal Communications Commission helpful:  
 "How to Identify and Resolve Radio-TV Interference Problems."  
 This booklet is available from the U.S. Government Printing Office, Washington D.C. 20402. Stock No. 004-000-00345-4.

• This applies only to products distributed by YAMAHA CORPORATION OF AMERICA.

**Wichtiger Hinweis für die Benutzung in der Bundesrepublik Deutschland.**

**Bescheinigung des Importeurs**

Hiermit wird bescheinigt, daß der / die / des

**Digital Drummer Typ: EMR-1**

(Gerät, Typ, Bezeichnung)

in Übereinstimmung mit den Bestimmungen der

**VERFÜGUNG 1046/84**

(Amtsblattverfügung)

funk-entstört ist.

Der Deutschen Bundespost wurde das Inverkehrbringen dieses Gerätes angezeigt und die Berechtigung zur Überprüfung der Serie auf Einhaltung der Bestimmungen eingeräumt.

**Yamaha Europa GmbH**

Name des Importeurs

• Dies bezieht sich nur auf die von der YAMAHA EUROPA GmbH vertriebenen Produkte.

**YAMAHA**

YAMAHA CORPORATION  
PO Box 1, Hamamatsu, Japan