



# SILENT *Piano*™



Owner's manual  
Manuel de l'utilisateur  
Bedienungsanleitung  
Manual del usuario  
Uso e manutenzione  
Руководство пользователя  
使用说明书  
操作説明書

## **IMPORTANT NOTICE FOR THE UNITED KINGDOM**

### **Applies to power adaptor Connecting the Plug and Cord**

**IMPORTANT:**

THE WIRES IN THE MAINS LEAD ARE COLOURED IN ACCORDANCE WITH THE FOLLOWING CODE:

BLUE: NEUTRAL

BROWN: LIVE

As the colours of the wires in the mains lead of this apparatus may not correspond with the coloured markings identifying the terminals in your plug, proceed as follows:

The wire which is coloured BLUE must be connected to the terminal which is marked with the letter N or coloured BLACK .

The wire which is coloured BROWN must be connected to the terminal which is marked with the letter L or coloured RED.

Make sure that neither core is connected to the earth terminal of the three pin plug.



**ME10**

## **FCC INFORMATION (U.S.A):**

**IMPORTANT NOTICE: DO NOT MODIFY THIS UNIT!**

This product, when installed as indicated in the instructions contained in this manual, meets FCC requirements. Modifications not expressly approved by Yamaha may void your authority, granted by the FCC, to use the product.

**IMPORTANT:**

When connecting this product to accessories and/or another product use only high quality shielded cables. Cable/s supplied with this product MUST be used. Follow all installation instructions. Failure to follow instructions could void your FCC authorization to use to use this product in the USA.

**NOTE:**

This product has been tested and found to comply with the requirements listed in FCC Regulations, Part 15 for Class "B" digital devices. Compliance with these requirements provides a reasonable level of assurance that your use of this product in a residential environment will not result in harmful interference with other electronic devices. This requirement generates/ uses radio frequencies and, if not installed and used according to the instructions found in the users manual, may cause interference harmful to the operation of other electronic devices. Compliance with FCC regulations does not guarantee that interference will not occur in all installations. If this product is found to be the source of interference, which can be determined by turning the unit "OFF" and "ON", please try to eliminate the problem by using one of the following measures:

Relocate either this product or the device that is being affected by the interference.

Utilize power outlets that are on different branch (circuit breaker or fuse) circuits or install AC line filter/s.

In the case of radio or TV interference, relocate/reorient the antenna. If the antenna lead-in is 300 ohm ribbon lead, change the lead-in to co-axial type cable.

If these corrective measures do not produce satisfactory results, please contact the local retailer authorized to distribute this type of product. If you can not locate the appropriate retailer, please contact Yamaha Corporation of America, Electronic Service Division, 6600 Orangethorpe Ave, Buena Park, CA 90620

### Information for Users on Collection and Disposal of Old Equipment



This symbol on the products, packaging, and/or accompanying documents means that used electrical and electronic products should not be mixed with general household waste. For proper treatment, recovery and recycling of old products, please take them to applicable collection points, in accordance with your national legislation and the Directives 2002/96/EC.

By disposing of these products correctly, you will help to save valuable resources and prevent any potential negative effects on human health and the environment which could otherwise arise from inappropriate waste handling.

For more information about collection and recycling of old products, please contact your local municipality, your waste disposal service or the point of sale where you purchased the items.

#### [For business users in the European Union]

If you wish to discard electrical and electronic equipment, please contact your dealer or supplier for further information.

#### [Information on Disposal in other Countries outside the European Union]

This symbol is only valid in the European Union. If you wish to discard these items, please contact your local authorities or dealer and ask for the correct method of disposal.

### Information concernant la Collecte et le Traitement des déchets d'équipements électriques et électroniques



Le symbole sur les produits, l'emballage et/ou les documents joints signifie que les produits électriques ou électroniques usagés ne doivent pas être mélangés avec les déchets domestiques habituels. Pour un traitement, une récupération et un recyclage appropriés des déchets d'équipements électriques et électroniques, veuillez les déposer aux points de collecte prévus à cet effet, conformément à la réglementation nationale et aux Directives 2002/96/EC.

En vous débarrassant correctement des déchets d'équipements électriques et électroniques, vous contribuerez à la sauvegarde de précieuses ressources et à la prévention de potentiels effets négatifs sur la santé humaine qui pourraient advenir lors d'un traitement inapproprié des déchets.

Pour plus d'informations à propos de la collecte et du recyclage des déchets d'équipements électriques et électroniques, veuillez contacter votre municipalité, votre service de traitement des déchets ou le point de vente où vous avez acheté les produits.

#### [Pour les professionnels dans l'Union Européenne]

Si vous souhaitez vous débarrasser des déchets d'équipements électriques et électroniques veuillez contacter votre vendeur ou fournisseur pour plus d'informations.

#### [Information sur le traitement dans d'autres pays en dehors de l'Union Européenne]

Ce symbole est seulement valable dans l'Union Européenne. Si vous souhaitez vous débarrasser de déchets d'équipements électriques et électroniques, veuillez contacter les autorités locales ou votre fournisseur et demander la méthode de traitement appropriée.

### Verbraucherinformation zur Sammlung und Entsorgung alter Elektrogeräte



Befindet sich dieses Symbol auf den Produkten, der Verpackung und/oder beiliegenden Unterlagen, so sollten benutzte elektrische Geräte nicht mit dem normalen Haushaltsabfall entsorgt werden.

In Übereinstimmung mit Ihren nationalen Bestimmungen und den Richtlinien 2002/96/EC, bringen Sie alte Geräte bitte zur fachgerechten Entsorgung, Wiederaufbereitung und Wiederverwendung zu den entsprechenden Sammelstellen.

Durch die fachgerechte Entsorgung der Elektrogeräte helfen Sie, wertvolle Ressourcen zu schützen und verhindern mögliche negative Auswirkungen auf die menschliche Gesundheit und die Umwelt, die andernfalls durch unsachgerechte Müllentsorgung auftreten könnten.

Für weitere Informationen zum Sammeln und Wiederaufbereiten alter Elektrogeräte, kontaktieren Sie bitte Ihre örtliche Stadtdor Gemeindeverwaltung, Ihren Abfallentsorgungsdienst oder die Verkaufsstelle der Artikel.

#### [Information für geschäftliche Anwender in der Europäischen Union]

Wenn Sie Elektrogeräte ausrangieren möchten, kontaktieren Sie bitte Ihren Händler oder Zulieferer für weitere Informationen.

#### [Entsorgungsinformation für Länder außerhalb der Europäischen Union]

Dieses Symbol gilt nur innerhalb der Europäischen Union. Wenn Sie solche Artikel ausrangieren möchten, kontaktieren Sie bitte Ihre örtlichen Behörden oder Ihren Händler und fragen Sie nach der sachgerechten Entsorgungsmethode.

### Información para Usuarios sobre Recolección y Disposición de Equipamiento Viejo



Este símbolo en los productos, embalaje, y/o documentación que se acompañe significa que los productos electrónicos y eléctricos usados no deben ser mezclados con desechos hogareños corrientes. Para el tratamiento, recuperación y reciclado apropiado de los productos viejos, por favor llévelos a puntos de recolección aplicables, de acuerdo a su legislación nacional y las directivas 2002/96/EC.

Al disponer de estos productos correctamente, ayudará a ahorrar recursos valiosos y a prevenir cualquier potencial efecto negativo sobre la salud humana y el medio ambiente, el cual podría surgir de un inapropiado manejo de los desechos.

Para mayor información sobre recolección y reciclado de productos viejos, por favor contacte a su municipio local, su servicio de gestión de residuos o el punto de venta en el cual usted adquirió los artículos.

#### **[Para usuarios de negocios en la Unión Europea]**

Si usted desea deshacerse de equipamiento eléctrico y electrónico, por favor contacte a su vendedor o proveedor para mayor información.

#### **[Información sobre la Disposición en otros países fuera de la Unión Europea]**

Este símbolo sólo es válidos en la Unión Europea. Si desea deshacerse de estos artículos, por favor contacte a sus autoridades locales y pregunte por el método correcto de disposición.

### Informazioni per gli utenti sulla raccolta e lo smaltimento di vecchia attrezzatura



Questo simbolo sui prodotti, sull'imballaggio, e/o sui documenti che li accompagnano significa che i prodotti elettriche e elettroniche non dovrebbero essere mischiati con i rifiuti domestici generici.

Per il trattamento, recupero e riciclaggio appropriati di vecchi prodotti, li porti, prego, ai punti di raccolta appropriati, in accordo con la Sua legislazione nazionale e le direttive 2002/96/CE.

Smaltendo correttamente questi prodotti, Lei aiuterà a salvare risorse preziose e a prevenire alcuni potenziali effetti negativi sulla salute umana e l'ambiente, che altrimenti potrebbero sorgere dal trattamento improprio dei rifiuti.

Per ulteriori informazioni sulla raccolta e il riciclaggio di vecchi prodotti, prego contatti la Sua amministrazione comunale locale, il Suo servizio di smaltimento dei rifiuti o il punto vendita dove Lei ha acquistato gli articoli.

#### **[Per utenti imprenditori dell'Unione europea]**

Se Lei desidera disfarsi di attrezzatura elettrica ed elettronica, prego contatti il Suo rivenditore o fornitore per ulteriori informazioni.

#### **[Informazioni sullo smaltimento negli altri Paesi al di fuori dell'Unione europea]**

Questo simbolo è validi solamente nell'Unione europea. Se Lei desidera disfarsi di questi articoli, prego contatti le Sue autorità locali o il rivenditore e richieda la corretta modalità di smaltimento.

## Для инструментов с заземленным кабелем питания

### ПРЕДУПРЕЖДЕНИЕ

---

#### Электропитание/кабель питания

- Подключайте только к электросети с соответствующим напряжением и защитным заземлением. Неправильное заземление может вызвать поражение электрическим током.

#### Беречь от воды

- Не держите инструмент там, где он может попасть под дождь, рядом с водой, а также в сырых и влажных помещениях. Не ставьте на него емкости с жидкостью, которая может пролиться и попасть в отверстия.

#### Беречь от огня

- Не ставьте на инструмент зажженные свечи и другие подобные предметы. Горящий предмет может упасть и вызвать пожар.

### ВНИМАНИЕ!

---

#### Место установки

- При установке инструмента убедитесь в том, что используемая электрическая розетка легкодоступна. При возникновении какого-либо сбоя или неисправности немедленно отключите питание инструмента и отсоедините кабель питания от электросети. Даже если питание устройства отключено, инструмент продолжает в минимальном количестве потреблять электроэнергию. Если инструмент не используется в течение длительного времени, отсоедините кабель питания от электросети.

## Для инструментов с незаземленным кабелем питания

### ПРЕДУПРЕЖДЕНИЕ

---

#### Беречь от воды

- Не держите инструмент там, где он может попасть под дождь, рядом с водой, а также в сырых и влажных помещениях. Не ставьте на него емкости с жидкостью, которая может пролиться и попасть в отверстия.

#### Беречь от огня

- Не ставьте на инструмент зажженные свечи и другие подобные предметы. Горящий предмет может упасть и вызвать пожар.

### ВНИМАНИЕ!

---

#### Место установки

- При установке инструмента убедитесь в том, что используемая электрическая розетка легкодоступна. При возникновении какого-либо сбоя или неисправности немедленно отключите питание инструмента и отсоедините кабель питания от электросети. Даже если питание устройства отключено, инструмент продолжает в минимальном количестве потреблять электроэнергию. Если устройство не используется в течение длительного времени, отсоедините кабель питания от электросети.

## Для инструментов с блоком питания

### ПРЕДУПРЕЖДЕНИЕ

---

#### Беречь от воды

- Не держите инструмент там, где он может попасть под дождь, рядом с водой, а также в сырых и влажных помещениях. Не ставьте на него емкости с жидкостью, которая может пролиться и попасть в отверстия.

#### Беречь от огня

- Не ставьте на инструмент зажженные свечи и другие подобные предметы. Горящий предмет может упасть и вызвать пожар.

### ВНИМАНИЕ!

---

#### Место установки

- При установке инструмента убедитесь в том, что используемая электрическая розетка легкодоступна. При возникновении какого-либо сбоя или неисправности немедленно отключите питание инструмента и отсоедините кабель питания от электросети. Даже если кнопка питания находится в положении STANDBY, устройство продолжает в минимальном количестве потреблять электроэнергию. Если устройство не используется в течение длительного времени, отсоедините кабель питания от электросети.

部件名称	有毒有害物质或元素					
	铅 (Pb)	汞 (Hg)	镉 (Cd)	六价铬 (Cr(VI))	多溴联苯 (PBB)	多溴二苯醚 (PBDE)
外壳、框架	×	○	○	○	○	○
印刷线路板	×	○	○	○	○	○

○：表示该有毒有害物质在该部件所有均质材料中的含量均在SJ/T 11363-2006标准规定的限量要求以下。

×：表示该有毒有害物质至少在该部件的某一均质材料中的含量超出SJ/T 11363-2006标准规定的限量要求。

(此产品符合EU的RoHS指令。)

(この製品はEUのRoHS指令には適合しています。)

(This product conforms to the RoHS regulations in the EU.)

(Dieses Produkt entspricht der RoHS-Richtlinie der EU.)

(Ce produit est conforme aux réglementations RoHS de l'UE.)

(Este producto cumple con los requisitos de la directiva RoHS en la UE.)

---



此标识适用于在中华人民共和国销售的电子信息产品。  
标识中间的数字为环保使用期限的年数。



SILENT *Piano*<sup>TM</sup>

Owner's manual

## SPECIAL MESSAGE SECTION

---

This product utilizes an external power supply (adaptor). DO NOT connect this product to any power supply or adaptor other than one described in the manual, on the name plate, or specifically recommended by Yamaha.

### **WARNING:**

Do not place this product in a position where anyone could walk on, trip over, or roll anything over power cords or other connecting cords. The use of an extension cord is not recommended! If you must use an extension cord, the minimum wire size for a 25' cord (or less) is 18 AWG.

### **NOTE:**

The smaller the AWG number, the larger the current handling capacity. For longer extension cords, consult a local electrician.

This product should be used only with the components supplied or; a cart, rack, or stand that is recommended by Yamaha. If a cart, etc., is used, please observe all safety markings and instructions that accompany the accessory product.

### **SPECIFICATIONS SUBJECT TO CHANGE:**

The information contained in this manual is believed to be correct at the time of printing. However, Yamaha reserves the right to change or modify any of the specifications without notice or obligation to update existing units.

Do not attempt to service this product beyond that described in the user-maintenance instructions. All other servicing should be referred to qualified service personnel.

This product, either alone or in combination with an amplifier and headphones or speaker/s, may be capable of producing sound levels that could cause permanent hearing loss. DO NOT operate for a long period of time at a high volume level or at a level that is uncomfortable. If you experience any hearing loss or ringing in the ears, you should consult an audiologist.

### **IMPORTANT:**

The louder the sound, the shorter the time period before damage occurs.

Some Yamaha products may have benches and/or accessory mounting fixtures that are either supplied as a part of the product or as optional accessories. Some of these items are designed to be dealer assembled or installed. Please make sure that benches are stable and any optional fixtures (where applicable) are well secured BEFORE using. Benches supplied by Yamaha are designed for seating only. No other uses are recommended.

### **NOTICE:**

Service charges incurred due to lack of knowledge relating to how a function or effect works (when the unit is operating as designed) are not covered by the manufacturer's warranty, and are therefore the owners responsibility. Please study this manual carefully and consult your dealer before requesting service.

### **ENVIRONMENTAL ISSUES:**

Yamaha strives to produce products that are both user safe and environmentally friendly. We sincerely believe that our products and the production methods used to produce them, meet these goals. In keeping with both the letter and the spirit of the law, we want you to be aware of the following:

#### **Disposal Notice:**

Should this product become damaged beyond repair, or for some reason its useful life is considered to be at an end, please observe all local, state, and federal regulations that relate to the disposal of products that contain lead, batteries, plastics, etc. If your dealer is unable to assist you, please contact Yamaha directly.

## PLEASE KEEP THIS MANUAL



## Contents

Accessories .....	1	Adjusting the Pitch (Tuning) .....	4
Installation .....	1	Setting the DDE (Dynamic Damper Effect) .....	5
Attaching the Headphones Hanger .....	1	Returning Settings to Their Default Configuration (Reset All) .....	5
Connecting the AC Adaptor .....	2	Troubleshooting .....	6
Part Names .....	2	Specifications .....	6
Using the Silent Piano™ Function .....	3		
Setting the Amount of Reverb .....	4		

## Accessories

- AC adaptor (PA-5D/PA-150)
- Headphones
- Headphones hanger and attachment screws
- Owner's manual

## Installation

- Avoid placing this instrument in direct sunlight, in close proximity to heating equipment or other high-temperature areas, or in locations with a high degree of humidity.
- Avoid placing this instrument in dusty or dirty areas.
- Do not expose this instrument to spray or fumes.
- Use only the specified AC adaptor. Use of any other adaptor may result in damage.

## Attaching the Headphones Hanger

Attach the hanger to the underside of the control box with the two screws supplied.

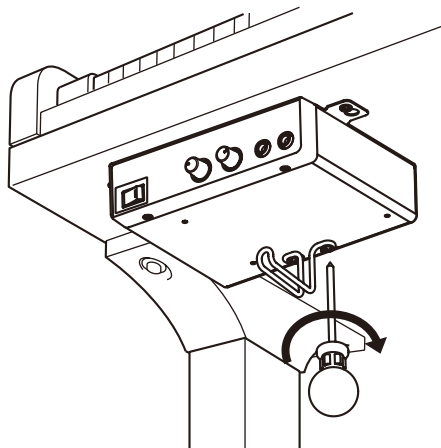

## Connecting the AC Adaptor

- 1** Connect the AC adaptor to the DC IN 12V socket at the rear of the control box.
- 2** Loop the cord through the hook on the piano, as shown.
- 3** Connect the AC adaptor to the AC wall outlet.

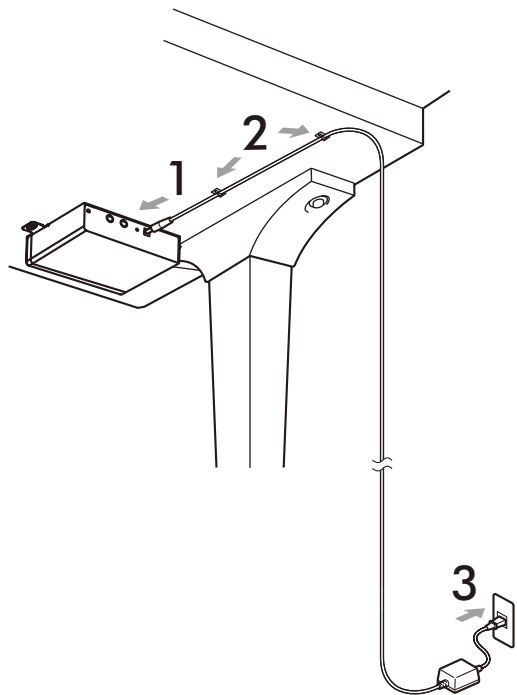

### Caution

- Use the Yamaha PA-5D/PA-150 AC adaptor.
- Do not stretch the cord or bend its ends.
- Do not attempt to use the cord if it is stretched or if the ends of the cord have been bent. Attempting to do so may cause interruptions to the power supply.
- Always turn off the main unit power before disconnecting the AC adaptor.
- When you wish to move the Silent Piano, unplug the AC adaptor from the AC outlet and disconnect it from the DC IN 12V socket at the rear of the control box before proceeding.
- Unplug the AC adaptor from the AC outlet if you do not intend to use the instrument for an extended period of time.

## Part Names

### ■ Control box-Front panel

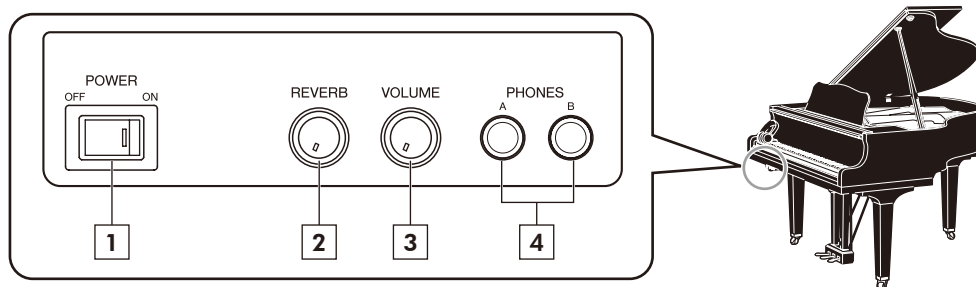

#### **1** Power switch (POWER)

Used to turn the digital piano on and off.

#### **2** Reverb control (REVERB)

Adjusts the amount of reverb.

#### **3** Volume control (VOLUME)

Adjusts the volume for both headphones simultaneously.

#### **4** Two headphone sockets (PHONES)

You can connect two stereo headphones, allowing you to share your playing with another person.

# Using the Silent Piano™ Function

- 1** Pull the silent lever towards you until you hear a click and feel the mechanism catch.

This prevents the hammers from actually striking the strings.

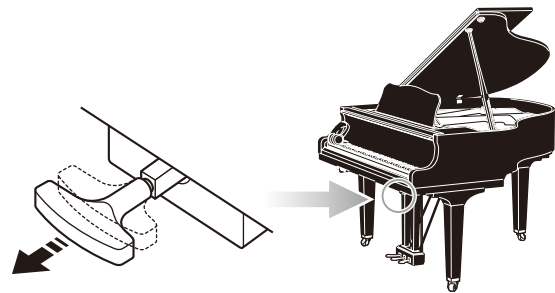

- 2** Plug the headphones into the PHONES socket.

You can use two sets of headphones simultaneously.

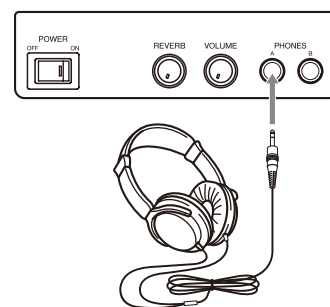

- 3** Turn the power on.

The POWER lamp lights green.

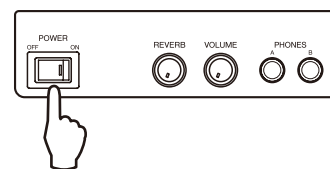

- 4** Adjust the volume with the VOLUME control.

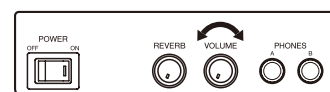

## Caution

To prevent damage to your hearing, refrain from raising the volume to excessive levels, and do not use the headphones for extended periods of time.

## Setting the Amount of Reverb

Reverb adds echo to the sound to give it more fullness and reverberation.

Use the REVERB control to adjust the depth (the degree to which the reverb effect is applied to the sound). To turn the reverb off, set the control in the far left position.

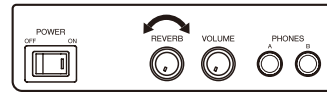

You can also change the type of reverb to apply.

Reverb type	Effect	Setting method
Room	Reverberation similar to that heard in a normal room	Hold down the A-1, A#-1, and B-1 keys and press C2.
Hall 1 (Default setting)	Reverberation similar to that heard in a small concert hall	Hold down the A-1, A#-1, and B-1 keys and press D2.
Hall 2	Reverberation similar to that heard in a large concert hall	Hold down the A-1, A#-1, and B-1 keys and press E2.
Stage	Reverberation similar to that heard on a stage	Hold down the A-1, A#-1, and B-1 keys and press F2.

The reverb function reverts to its default setting when you turn the power off.

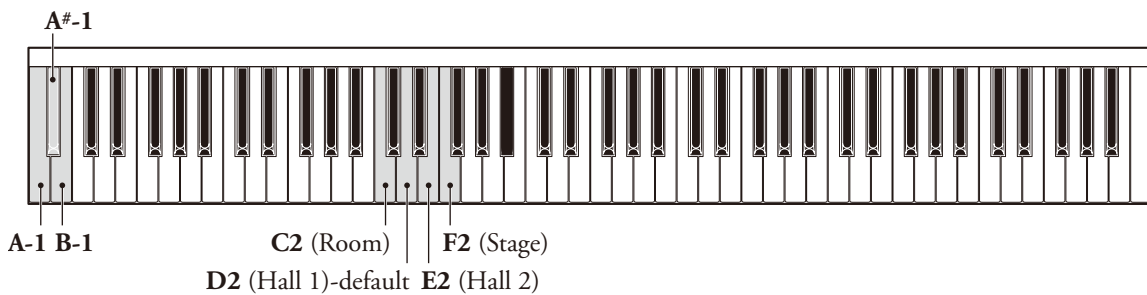

## Adjusting the Pitch (Tuning)

The pitch of this instrument is set so that A3=440Hz. You can fine tune the pitch up or down 65 cents in 1 cent steps (100 cents is equal to 1 semitone).

Operation	Setting method
Raise the pitch	Hold down the A-1 and B-1 keys and press any one of the keys between C3 and B3.
Lower the pitch	Hold down the A-1 and A#-1 keys and press any one of the keys between C3 and B3.
Return to default tuning	Hold down the A-1, A#-1, and B-1 keys and press any one of the keys between C3 and B3.

The pitch setting is stored when you turn the instrument off.

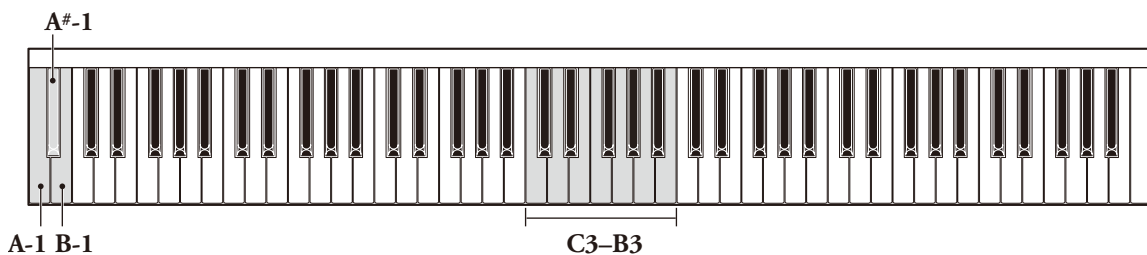

## Setting the DDE (Dynamic Damper Effect)

The DDE (Dynamic Damper Effect) recreates the subtle resonances that occur when you depress the damper pedal on an acoustic piano. You can set the DDE to suit your preferences.

Operation	Setting method
Turn the DDE off	Hold down the A-1, A#-1, and B-1 keys and press C6.
Turn the DDE on (5 levels)	Hold down the A-1, A#-1, and B-1 keys and press D6, E6, F6, G6 or A6. (A6 is the deepest DDE setting. The default setting is E6)

The DDE setting does not change when you turn the power off.

### Note

Even when the DDE is turned off, the sound continues as if you had pressed the damper pedal, but without any resonating effect.

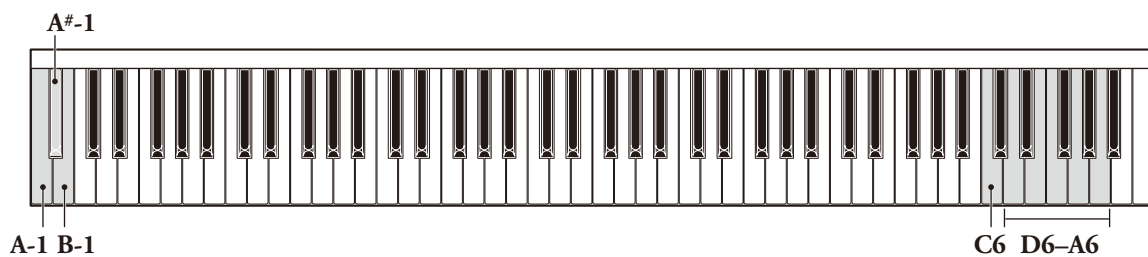

## Returning Settings to Their Default Configuration (Reset All)

You can reset all settings to their default state.

Hold down the A-1, A#-1, and B-1 keys and press C7, the highest key on the keyboard.

This returns reverb, pitch, and DDE to their default settings.

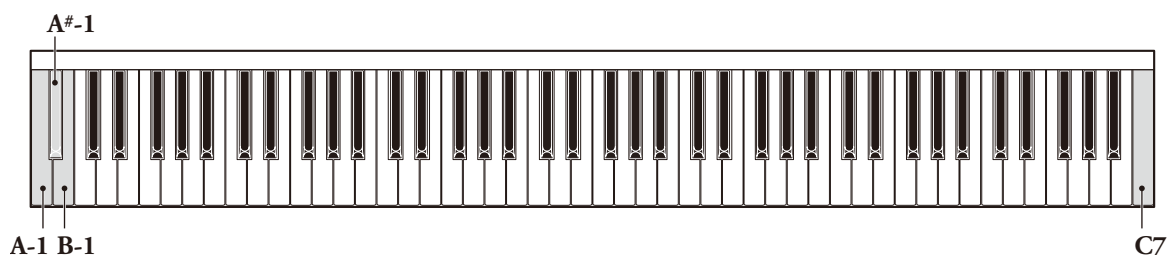

## Troubleshooting

---

If you have problems with your Silent Piano, here are a few troubleshooting tips. If you cannot solve the problem easily yourself, consult your Yamaha piano dealer. DO NOT attempt to repair the piano or the AC adaptor yourself.

🔊 **The POWER lamp lights but the instrument does not emit any sound, and the pedal has no effect.**

- Are the cable connectors firmly connected to the rear of the control box? The instrument may not output sound and the pedal may not function if the cables are disconnected for any reason.

🔊 **The sound does not stop when I release a key.**

**The sound lingers.**

**The sound is unclear and has an echo.**

- The reverb knob may be set to its maximum setting. Adjust the reverb to an optimal level.
- Is the DDE set to an appropriate level?

🔊 **The sound is distorted.**

- Playing chords strongly with the volume set at maximum level may cause distortion of the sound, but is not an indicator of damage to the instrument.

## Specifications

---

Keyboard	88 keys
Pedal	Shift pedal, Sostenuto pedal/Bass sustain pedal, Damper pedal
Voice	Piano
Polyphony	32-note stereo sampling
Sensors	Continuous detection key sensor Continuous detection damper pedal sensor ON/OFF detection shift pedal sensor
Controls	Power switch, Volume control, Reverb depth control Reverb type switch (4 types), Pitch adjustment DDE adjustment (Damper pedal resonance), All reset
Terminals	Headphones x 2, Power input terminal DC IN 12V
Rated power	DC12V 6W
Supplied accessories	AC adaptor (PA-5D/PA-150), Headphones, Headphones hanger, Owner's manual

**YAMAHA CORPORATION**  
**P.O.Box 3, Hamamatsu, 430-8651 Japan**